

NON-TECTONIC SYSTEMS: CURVED STRUCTURES VAULTS, DOMES AND BARREL-VAULTS*

M. PÁRKÁNYI, L. HAJDÚ, J. BARCZA, Z. SZIRMAI

Institute of Building Constructions and Equipments,
Technical University, H-1521 Budapest

Received December 15, 1987
Presented by Prof. Dr. O. László

Abstract

Our present study — the concluding fifth in the series of articles to introduce the non-tectonic systems and the first to extend research into the field of the curved structures — expounds the methodology of how to connect in practice the adaptation of vaults, domes and barrel-vaults with the non-tectonic building methods on the industrial level. It is evident that the non-tectonic building, already by virtue of its universality, cannot give up using forms of spaces which enrich architecture in any case, but it is also evident that it cannot renounce the standpoints of industrialization of building either. The non-tectonic systems are based on the recognition that tectonics is not the only possible axiom of building and the adaptation of curved structures gives a further proof that such an axiomatic change is realizable and that we may open new hitherto unknown ways of industrialization of building if we break with the axiom of tectonics.

Introduction: Scope of the research 1971—87

At the Institute of Building Constructions and Equipments ever since 1971, many years' research work has been spent on the formation of a new coherent theoretical, technological and economic approach to mass-construction in developing countries.*** Initial research strived to elaborate the theory of construction [12] and succeeded in proving scientifically that in the age of industrialized building the axiom of tectonics — that is the simple principle of putting loadbearing structural elements on one another — is not the only possible axiom of building but it has a working alternative. This is how the *non-tectonic systems* arose.

Success of a series of pilot tests — the experimental non-tectonic structural unit [3], the experimental non-tectonic maisonette [4], the experimental non-tectonic hall [7], etc. — carried out 1971—74 urged us to solve essential technology problems of different adaptations of the system, therefore since 1975, research had two main lines.

The first was the original line of research concerned with the *adaptation of non-tectonic systems to low-cost housing in developing countries* [2]. It was given

*** See: References

significant support by UNIDO which has for some time been in contact with the Hungarian experts [6]. Considering the results achieved hitherto the system was considered very promising for use in hot-arid countries (where gypsum is available) for low-cost housing, community centres, industrial workshops, rural health centres [9] and the technology to be ripe for testing under actual conditions in a developing country. Now, in the period that followed, quite a series of pilot projects, plans for low-cost housing, industrial workshops, schools etc. were elaborated for different developing countries (inter alia: Egypt, Somalia [6], Senegal, South Yemen [11], Iraq) but due to the well-known — mainly political-economic — circumstances, none of them could be realized up to this time, most unfortunately.

The other line of research was devoted to the *making of an appropriate technology*, that is the calling into being building methods of technological relevance for hot arid tropical areas [14] capable of satisfying a system of determined requirements possibly most favourable in a given space and in a given time.

Since the non-tectonic systems are not bound to a particular building method — the same building, namely, can be realized in many different ways depending on the simultaneous consideration of all social, technical, economic, geographic, zonal, functional, architectural etc. factors — consequently quite a series of building methods can be at the builder's disposal to ensure the most favourable solution. This is how at last *the seven basic methods of non-tectonic building: the in-situ, the lifting, the box-unit, the box-frame unit, the closed cellular, the lift-cell and the tilt-lift building methods were elaborated.*

*

Having finished elaboration of the seven basic methods of nontectonic building, in 1985 we started on a new phase of research, again on two main lines.

The first line devoted to the *further development of non-tectonic systems to curved structures* basically aims at elaborating the outline of the methodology. For this purpose the work is designed to include the making of architectural (design) variations on the fundamental stereometric forms of the non-tectonic curved structures; the elaboration of structural (manufacture) variations on the industrialized forms of producing domes and vaults and finally, the working out of technological (assembly) variations and combinations on building methods of technological relevance for hot arid tropical areas.

The other line of research was inserted into our programme on the request of the Ad hoc IYSH Committee for the purpose of elaborating our scientific *contribution to the IYSH Research Action Area* (covering the field of “identifying and testing low-cost techniques for construction and upgrading of community

services, especially those using local materials and skills"). To do so, we decided to *restate main results of our research into non-tectonic systems* in five subsequent studies, as follows:

1. *An illustrated report of the open, lightweight silicatebased building systems.*

[13] In this abundantly illustrated report we aimed at giving a dense account of our research work which led us to the fundamental recognition that tectonics is not the only possible axiom of building and prove that the axiomatic change is realizable and that we may open new, hitherto, unknown ways of industrialization of building;

2. *Building methods of technological relevance for hot arid tropical areas* [14].

In this study we first introduce the theoretical outline of technological irreversibility and then two fundamentally new building methods particularly fit for hot arid countries are expounded in detail. Both technologies — *the box-frame unit building method and the closed cellular building method* — are concerned with *low-cost housing*, introduce adaptations of the non-tectonic systems for solving different problems of mass-housing in developing countries and have been designed in such a way as to give optimum solution for the social-sociological, technical-economic, climatic-geographic, architectural-constructional requirements prevalent today in the P. D. R. of Yemen;

3. *Communal buildings: the lift-cell building method, and*

4. *Industrial workshops: the tilt-lift building method.* In these separate studies two further non-tectonic building methods of technological relevance for hot arid tropical areas are expounded in detail. Both technologies exemplify a further development of the system to solving problems of mass-construction of communal buildings and industrial workshops, respectively;

5. *Curved structures: vaults, domes and barrel-vaults.* In this article finally, we summarize our results achieved in the further development of non-tectonic systems to curved structures, that is the fundamental historical stereometric forms of vaults, domes and barrel-vaults mentioned already above.

Our present study is the concluding *fifth* in the series of articles to introduce the non-tectonic systems.

Section I

Adaptation of non-tectonic systems to curved structures

Short description of non-tectonic systems and technological relevance

The themes — *non-tectonic systems* and *technological relevance* — have already been treated in detail in the series of articles devoted to introducing main results of our research in the *Periodica** therefore, here only short descriptions will be given to remind the Reader.

*

The non-tectonic systems are open, lightweight, silicate-based building systems founded on the Gutenberg principled fragmentation.

In the non-tectonic systems, building is *complementary operation*, that is, a process in which we combine the *factory production of surface elements with some kind of technology of pouring in of concrete either in the factory or on the building site*, whereby we produce structural units (in the factory) or call into being the structures themselves (on the building site).

In the non-tectonic building method the final product (that is the building) is realized in such a specific building process where additivity (that is the axiom of building) is founded on the simultaneous non-loadbearing (non-tectonic) capacity and temporary or incidental instability of semantically meaningless (Gutenberg-principled) surface elements. In this building method the immediate product of manufacture is not the load-bearing structure but its surface and therefore alignment of surface elements of vertical and horizontal structures does not lead to immediately load-supporting — load-transferring (that is: tectonic) junctions between these surface elements.

*

In the industrialized building *technological relevance* is defined as an immanent (inherent) quality of manufactured structural systems by means of which these building — structural — technological systems can most favourably satisfy a system of concretely determined requirements in a concretely determined particular case.

The system of requirements of industrialized building, however, is extremely composite and complex not only because quite a series of technological, economical and social constituents have to be taken into consideration but first of all, because this system of requirements keeps constantly changing in space and in time. *A technology satisfying a system of determined requirements possibly*

* See: References 13, 14.

most favourably in a given space and in a given time inevitably loses its validity — its relevance — if applied at another time or in another place.

The degree of technological relevance in the industrialized building reaches its maximum in the non-tectonic systems. The combinatorial qualities of these systems, namely, offer almost unlimited possibilities for adaptation to requirements varying in space and in time and actually it is this circumstance which also renders it possible for the system to create a series of products ranging from individually manufactured individual products through individual products produced by massproduction methods up to mass-products produced by mass-production methods.

The fact that in the non-tectonic systems technological relevance reaches a maximum degree is of crucial importance from building industrialization point of view because it makes something possible that we could never realize in the mechanization-principled technologies, that is an equally *optimum solution of building tasks characterized by the most different levels of quantity or quality.*

Finally, it seems particularly expedient here to mention a technical-economic consideration definitely pertinent to this theme in support of our conviction, that *the real domain of the adaptation of non-tectonic systems is mass-housing, or rather, mass-construction in developing countries.* The consideration goes as follows:

Whilst in developed countries the specific cost of building constructions, or rather the specific cost of the primary loadbearing structures — that is to say: that specific part of the building cost where the silicate-based, lightweight, non-tectonic systems may save a particularly considerable sum of money — does not amount to more than approximately 10—20% of the total building cost, in developing countries exactly the opposite is relevant: *in developing countries, namely, the building cost of the primary loadbearing structures in low-cost housing may reach even 80—90% of the total building cost!*

*

BASIC METHODS OF NON-TECTONIC BUILDING: THE IN-SITU, THE LIFTING, THE BOX-UNIT, THE BOX-FRAME-UNIT, THE CLOSED CELLULAR, THE LIFT-CELL AND THE TILT-LIFT BUILDING METHODS

This study introduces *adaptations of the non-tectonic systems to curved structures* in such a way that it *couple different forms of curved structures — that is: vaults, domes and barrel-vaults — with different non-tectonic building methods on different levels of technological relevance.* We think it is important to remind the Reader here, on the pages to follow, on the basic building methods* and remark at the same time that these building methods can be expediently coupled with each other as well.

* See: References 13, 14, 15, 16.

In-situ building methods

The seven basic types of non-tectonic building methods have already been treated in detail, so here only figures and short descriptions are given.

In case of the *in-situ building method* the chronological and logical order of the building process itself corresponds to that of the mechanization based tectonic building, in so far as the building is erected "from below upwards", each structure is built in its final position, beams, beam-grid or floors following the erection of walls, or folded shell pillars (a, b, c) and the process (d, e, f) is repetitive (Fig. 1).

In-situ building methods

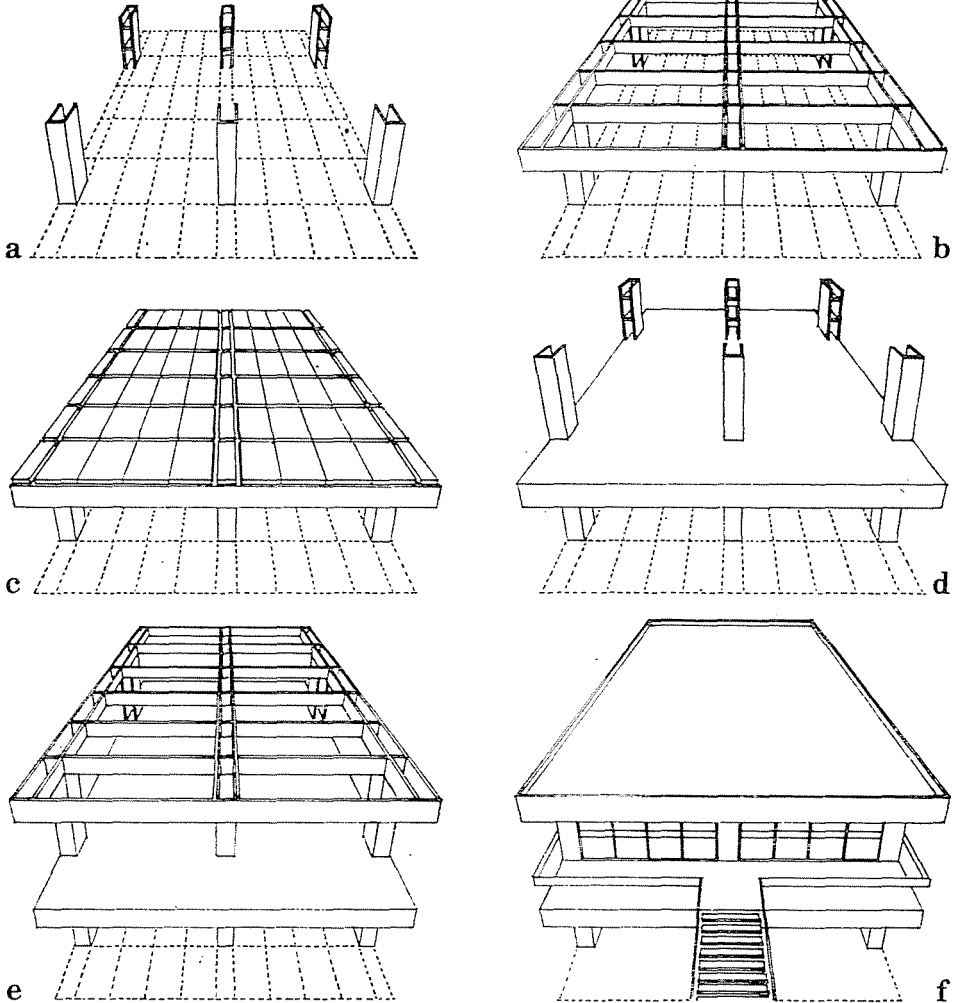

Fig. 1.

Lifting building methods

In case of the *lifting building method* the horizontal load-bearing structure — e.g. the beam-grid — is built exactly underneath the final “in-situ” position and it can be lifted into final position even by hand, through mechanical transmission.

The lifting apparatuses can also be integrated with the vertical load-bearing structure. In this case they are always mounted on top of the folded shell pillars or walls.

If the horizontal load-bearing structure is built and lifted in “linear” parts, the method is called “*lift-grid*”, if however, the horizontal load-bearing structure is built and lifted in “field-units”, the method is called “*lift-field*” (Fig. 2).

Lifting building methods

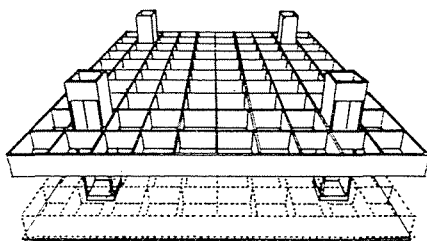
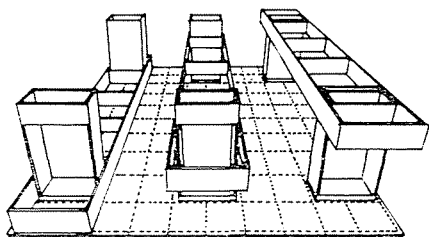

Fig. 2.

Box unit building methods

In case of the *box-unit building method* the box units constituting the building are produced in a factory in such a way that first we manufacture the non-loadbearing surface elements (a) then the load-bearing plane (wall- and floor) structural elements (b, c) and finally we assemble them into rigid, load-bearing box-units (d, e). On the site the building process is confined to the assembly of box-units (Fig. 3).

Box unit building methods

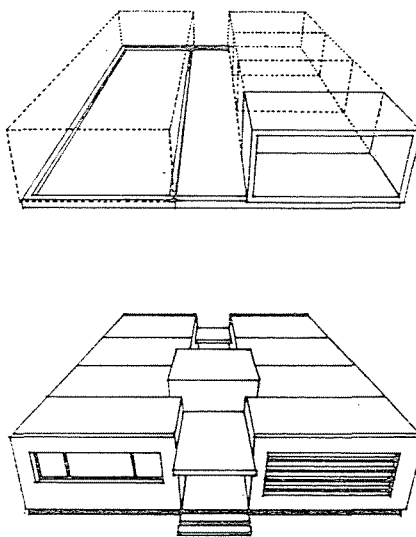
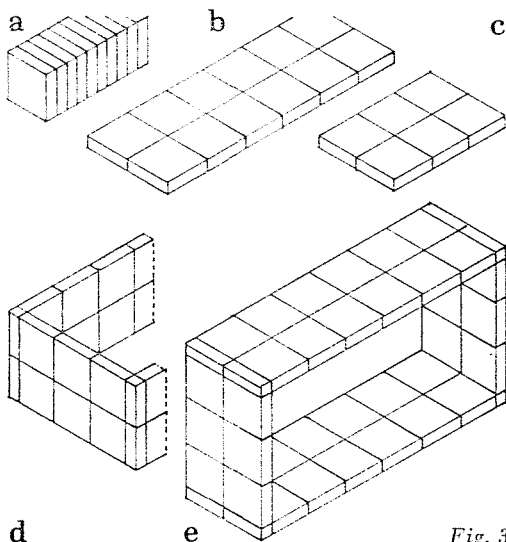

Fig. 3.

Box-frame unit building methods

In case of the *box-frame unit building method* the small box-units (the “ring”-units, the empty box-frame units) constituting the building are produced in a factory in such a way, that first we manufacture the non-tectonic surface elements (plane, gypsum elements) and then we assemble from them loadbearing small box-units (more accurately: pillar box-frames or beam box-frames).

On the site we first assemble the pillar box-frame units by fixing them in their final position, then — on top of these — we place the beam box-frame units, the structure is finally completed by the location and homogeneous junction of the tissue structural slabs (the floor elements and exterior wall elements) rendered already tectonic in the factory (Fig. 4).

Box-frame unit building methods

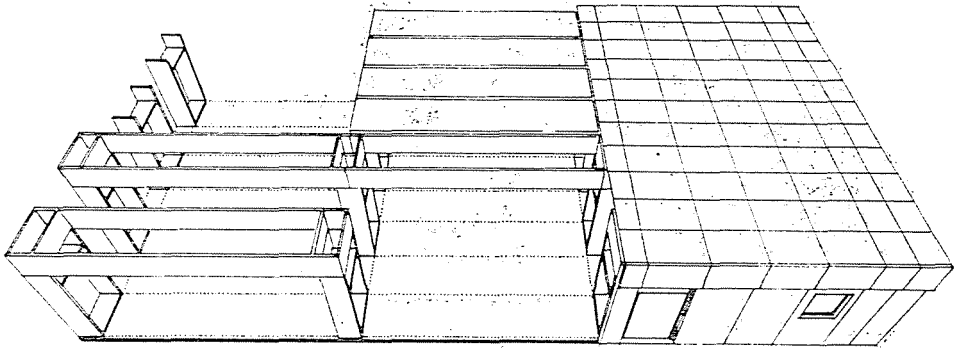

Fig. 4.

Closed cellular building methods

In case of the *closed-cellular building method* the constituents of the building: the box-units, the plane elements (that is: the empty box-frames and the anisotropic slabs of a parameter size in at least one direction) are produced in a factory in such a way that the large-sized tectonic pillar box-frame units and beam box-frame units are assembled from plane non-tectonic gypsum surface elements, whereas the large-sized tectonic anisotropic slabs are called into being from periodic large-sized gypsum surface elements supplied by a two-way channel system and a periodic system of closed internal cells, through pouring concrete into the channels and on top of the closed cells.

On the site the cycles of assembly, in case of the example shown in the figure, are essentially identical with those of the box-frame unit building method (Fig. 5).

Closed cellular building methods

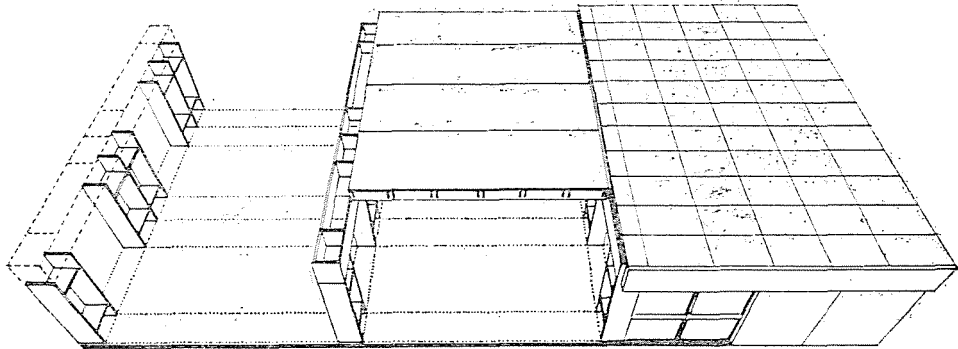
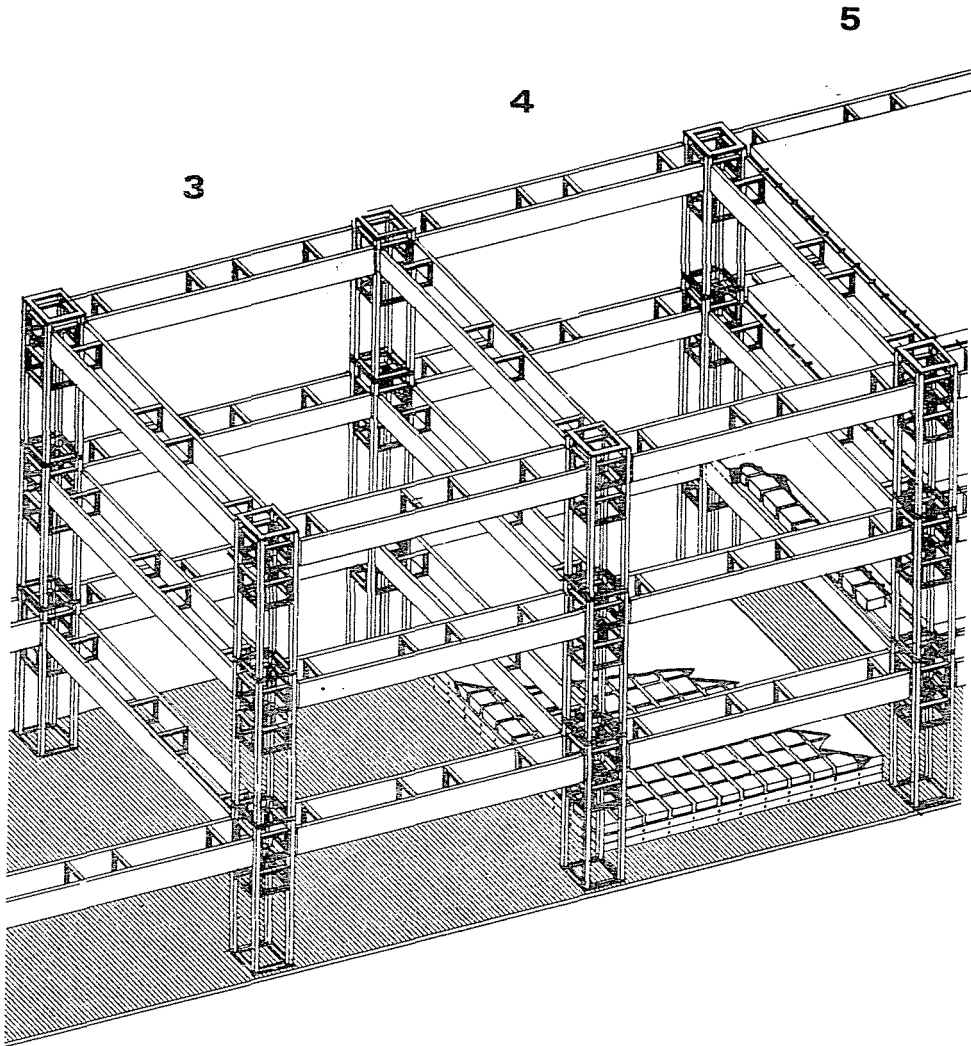

Fig. 5.

Lift-cell building methods

In case of the *lift-cell building method* the skeleton construction of the multi-level communal building — that is the pillar skeleton-frames and the beam box-frames — are manufactured in a factory in such a way that, in case of the pillars, we couple the column elements — that the manufactured tectonic linear r. c. structural elements — in fours by means of steel cradles and diaphragms, whereby we unite them into empty pillar skeleton frames, whereas in case of the beam box-frames we first produce the beam elements — that is the frozen r. c. shell plane structural elements — through preassembly of non-tectonic periodic surface elements and then we joint them in pairs by means of steel diaphragms, whereby we unite them into empty beam box-frames.

*Fig. 6.*

On the building site, the skeleton construction of the multi-level buildings, that is the pillar skeleton-frames and the beam box-frames are assembled immediately in their final in-situ position and connected to each other by heterogeneous junction, whereas the cellular floor-fields of parameter size in two directions are always assembled underneath in-situ position immediately on top of each other, and then lifted into in-situ position in due order and fixed first in dry, temporary in-situ position until final structural homogeneous connection is established. This is realized in the last step when the cellular floor-zones above the beam box-frames are assembled and concreted. (Fig. 6.)

Tilt-lift building methods

In case of the *tilt-lift building methods* a special combination of the in-situ, lifting and box-frame unit building methods complemented with a tilting opera-

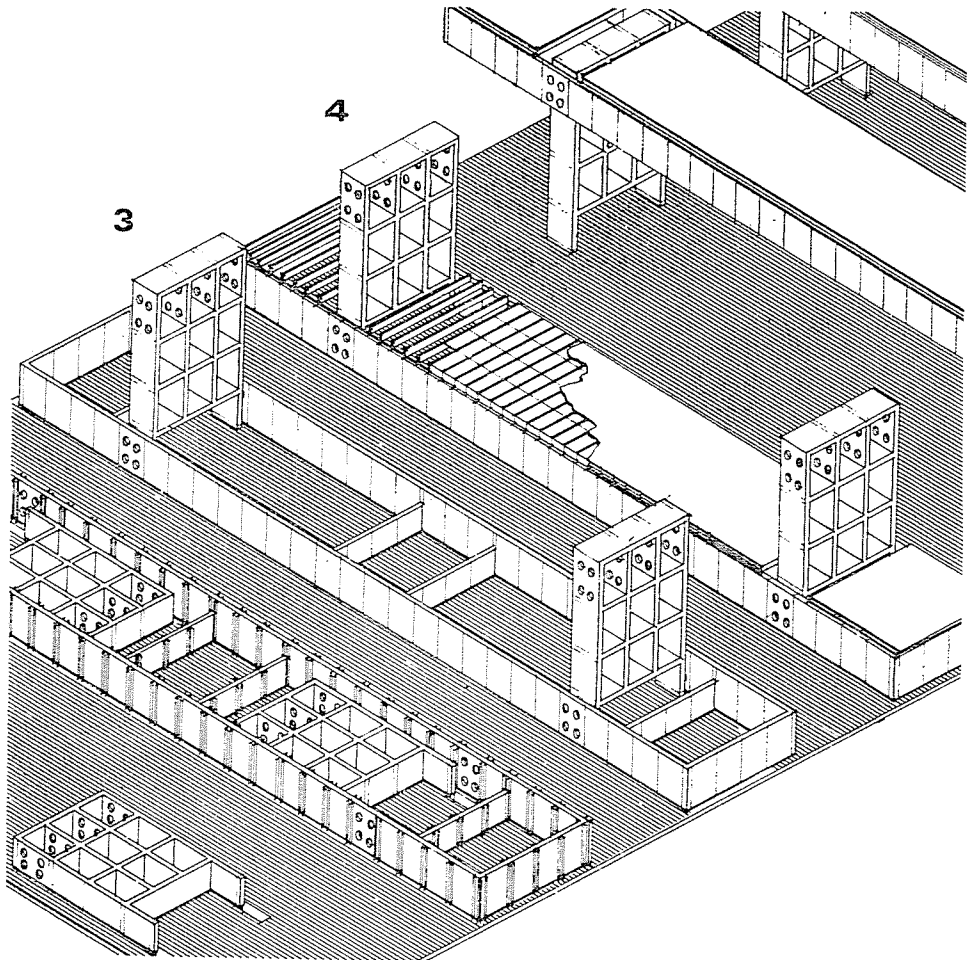

Fig. 7.

tion is used for calling into being long-span, one-level industrial buildings. In the factory — more accurately: in the transplantable factory — we only produce Gutenberg-principled non-tectonic gypsum surface elements.

On the building site each operation of the creation of the load-bearing structure is based on the additivity of surface elements, as follows: the pillar box-frame is assembled in the situation prior to tilting, and then, tilted around a fixed point into vertical position and fixed by homogeneous junction; the beam box-frame is assembled underneath the final in-situ position, and then, lifted into in-situ position and fixed by heterogeneous junction; the ribbed r.c. shell floors composed of linear tectonic structural elements (i.e.: beams manufactured on the building site) and non-tectonic surface elements (i.e.: plane gypsum surface-of-floor elements) are assembled and concreted partly underneath in-situ position, partly in final in-situ position (Fig. 7).

Some remarks on the outline of methodology

In each science, or branch of science — so, in the field of building science as well — we have to distinguish the questions of theory and practice from each other. Theory always includes the system of laws revealed by a given science, whereas the method always means the road connecting theory with practice.

Our present study is the first to extend the research of non-tectonic systems into the field of curved structures. By nature, this study is basically methodological since it analyses the road, that is the method of how to connect in practice the adaptation of curved structures — vaults, domes and barre vaults — with the already mentioned basic methods of non-tectonic building founded on the use of rectangular grid systems.

*

Analysis of the roads leading from practice to theory, or, from theory to its practical adaptation — this is the fundamental content of every methodology. In each science theory and method create an inseparable unity and this requirement applies to the general theory of non-tectonic building as well.

Each theory has a practical source. This, however, does not mean at all that this practical source calls into being the theory straight. Sciences have a relatively independent evolution, they not only connect with practice but with each other as well. It is this relatively independent development which renders it possible for the theory, to point ahead, to sketch out phenomena that will come into existence in course of a later practice. The theory, namely, by dealing with the scientific generalization of the practical experiences gives qualitatively more than the simple sum total of practical experience. That is why it is able to promote development, to render the new practice superior.

*

Practice, however, is not only the source of the theory but also its criterion. Validity of a theory — in general: the criterion of the technical judgement — can only be determined by the relevance offered by a given theory to satisfy various requirements of practice constantly changing in space and in time.

It was exactly such a change of practical character which was instrumental in the selection of our theme. The fundamental impulse to elaborate the curved structures of non-tectonic building, namely, was given by the circumstance, that in the practice of housing and communal building of many third world countries (Egypt, Mauretania, Iraq, Iran, India, etc.) particularly in the hot-arid tropical or subtropical areas there is an increasing tendency to take back the traditional stereometric historical forms of spaces that previously have already been declared as obsolete and to preach at the same time — not — quite without success — the return to building with clay.

It is evident, that the non-tectonic building — already by virtue of its universality — cannot give up using forms of spaces which enrich *architecture* in any case, but it is also evident that it cannot renounce the standpoints of *industrialization of building* either, and simply cannot fail to reply to a challenge which enforces meeting the undoubtedly justify *architectural* requirements exactly *against the building industry*.

Thus, in the last analysis, it was this circumstance which led us to introduce the adaptation of vaults, domes and barrel-vaults on the industrial level and to elaborate the methodology of adaptation.

*

The basic types of the curved structures of non-tectonic systems will be dealt with separately (in Sections 2, 3, and 4) and analysed in different structural variations. Amongst these variations at least one is devoted to show the vault connected with the box-frame unit building method, the dome with the closed cellular building method and, finally, the barrel-vault with the tilt-lift building method. The individual structural variations are introduced in three steps corresponding to the main — design, manufacture and assembly — aspects of the problem. The themes within the Sections are expounded in the following sequence: first we introduce the structural variations themselves, then, we illustrate the adaptation of the different curved structures to the respective building methods in such a way that we first demonstrate their location in the ground-plan and then in the system of grids on plan and in section and, finally, we analyse each structural variation from design, manufacture and assembly points of view.

*

Section 2

Vaults (V): Structural variations on the adaptation of vaults in the box-frame unit building method, on low, medium and high degree of complementarity

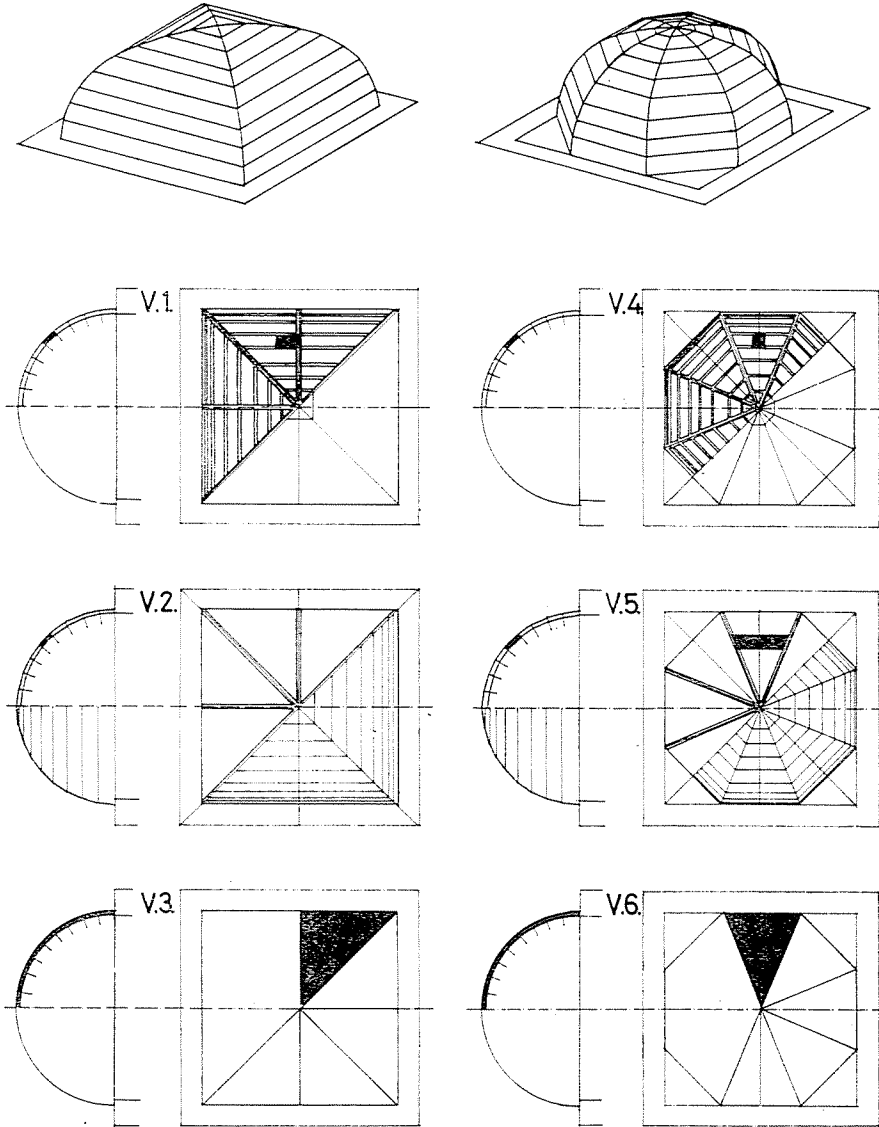

Fig. 8. Introduction of the structural variation V. 1. — V. 6. Each variation will be analysed in three consecutive steps corresponding to the phases of design — manufacture — assembly. Short verbal descriptions and drawings will put the emphasis on illustrating the principles

Adaptations of vaults in the box-frame unit building method*

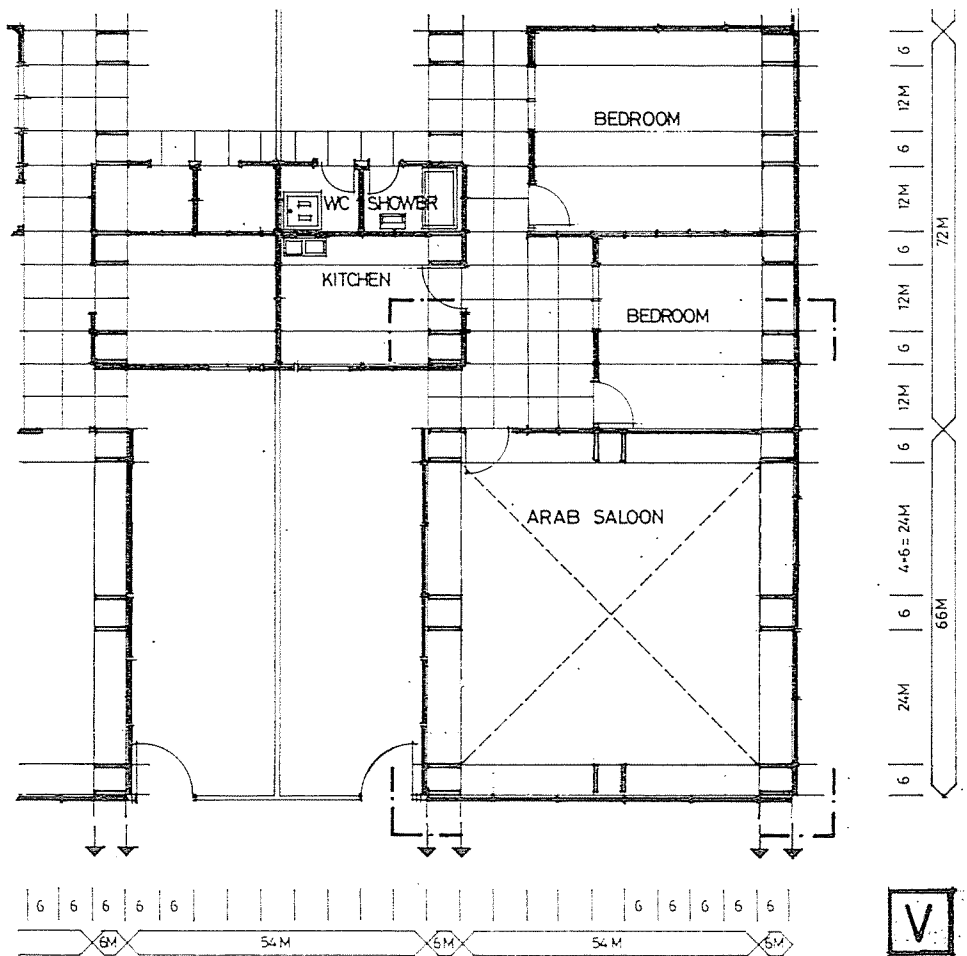

Fig. 9. Location of the vaulted space in the ground plan. From the methodological point of view the adaptation of vaults can most expediently be demonstrated in central-symmetrical arrangements. For this purpose the span dimension (54M) was kept constant, the o/a dimension of pillar-box frames ($6M \times 6M$) fits into the same zone. Characteristic problems of co-ordination always arise where the one-directional zone of the beam-box-frames meet the central-symmetrical area of the vaults. This is illustrated on the next page by Fig. 10

* The box-frame building method (see: Fig. 4.) has already been dealt with in detail in a previous study (see: Ref. 14.), therefore here (Fig. 9 and Fig. 10) only the most general aspects are demonstrated: the place of the vaulted space in the ground plan and its location in the system of grids.

The system of grids

Lines of the *primary grid on plan* determine the location of the pillar box-frames and the beam box-frames and, finally, the location of the vault itself. The grid dimensions are as follows:

$6M$ = width of pillar box-frames and beam box-frames;
 $54M = 9 \times 6M$ span

Lines of the *primary grid in section*
 determine the following planes:

the zero level of co-ordination: ($\pm 0.00m$);
 the lower level of beam box-frame ($+ 2.55m$);
 the upper level of beam box-frame ($+ 3.00m$);
 the springing level of vault ($+ 3.00m$).

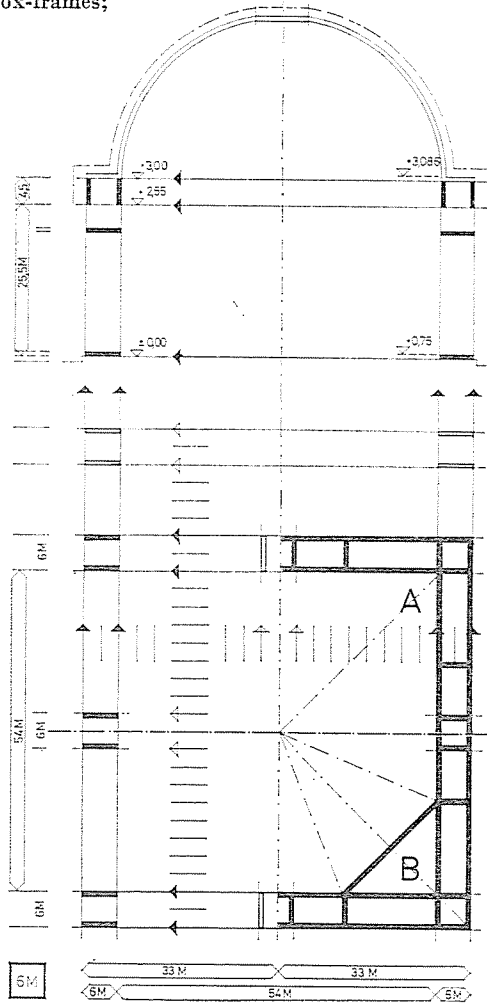

Fig. 10. Location of the vaulted space in the system of grids on plan and in section. The elements of the vault — i.e. the non-tectonic surface elements, the tectonic structural elements, etc. — are always introduced with the respective structural variations

Lines of the primary grid both on plan and in section establish a face-line reference which means that all the horizontal and vertical border planes of the pillar box-frames and beam box-frames coincide with these lines both in the zone of the “rooms” and in the central-symmetrical vaulted space. The adaptation — i.e. the linking of these two parts — is realized without problem.

The principle of manufacture of the elements remains the same. The variable dimensions are taken up by the convertible apparatuses.

V. 1. Design

Definition of structural variation V. 1.:

Structural variation on plan and in section, on:

- an adaptation of cloister vault in the box-frame unit building method (Figs 4, 9 and 10.);
- cloister vault composed of “blind-eighths” with semicircular meridian curve and constructed above a square;
- low degree of complementarity (low degree of readiness in the factory);

in the factory:

- on one-fold disintegration (on Gutenberg-principled decomposition);
- on non-tectonic elements with cylinder surface on both sides;

on the site:

- on the in-situ additivity of surface elements, (on calling into being the loadbearing structure on the building site).

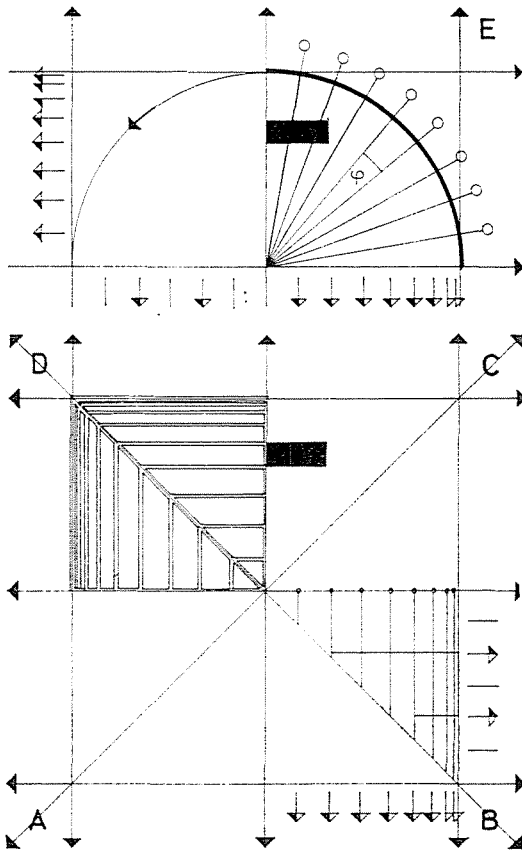

Fig. 11. The system of grids of variation V. 1. on plan and in section. Decomposition of the structure

Index: A. The system of primary grid-lines and grid-curves on plan; B. The system of secondary grid-lines on plan; C. Location of the element in the system of grid on plan; D. Location of junctions; E. The system of primary and secondary grid-lines and grid-curves in section; Location of the element in the system of grids in section

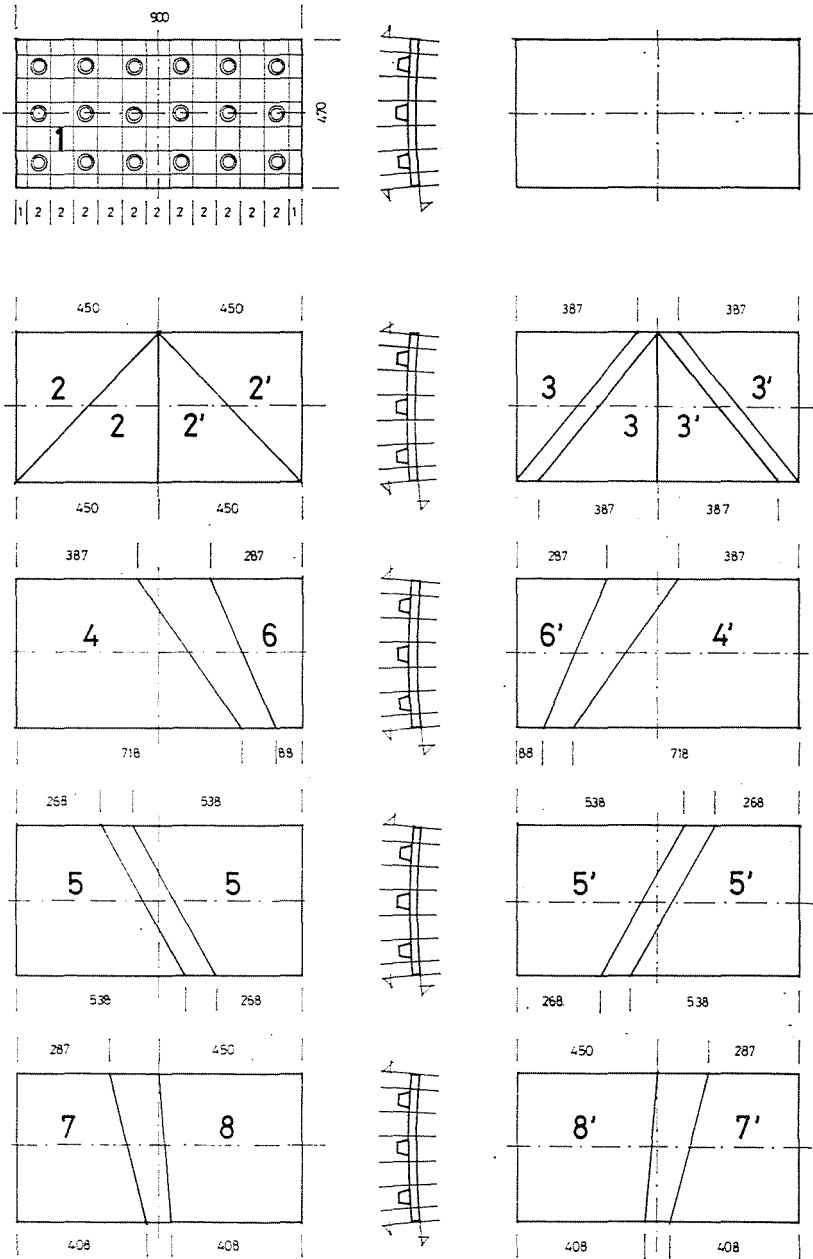

Fig. 12. Structural variation V. 1.: Basic non-tectonic elements. Non-tectonic periodic gypsum surface elements with cylinder surface on both "sides". These elements occur in the following structural variations: V. 1.; V. 3.; V. 4.; V. 6.; BV. 1. and BV. 3

V. 1. Manufacture

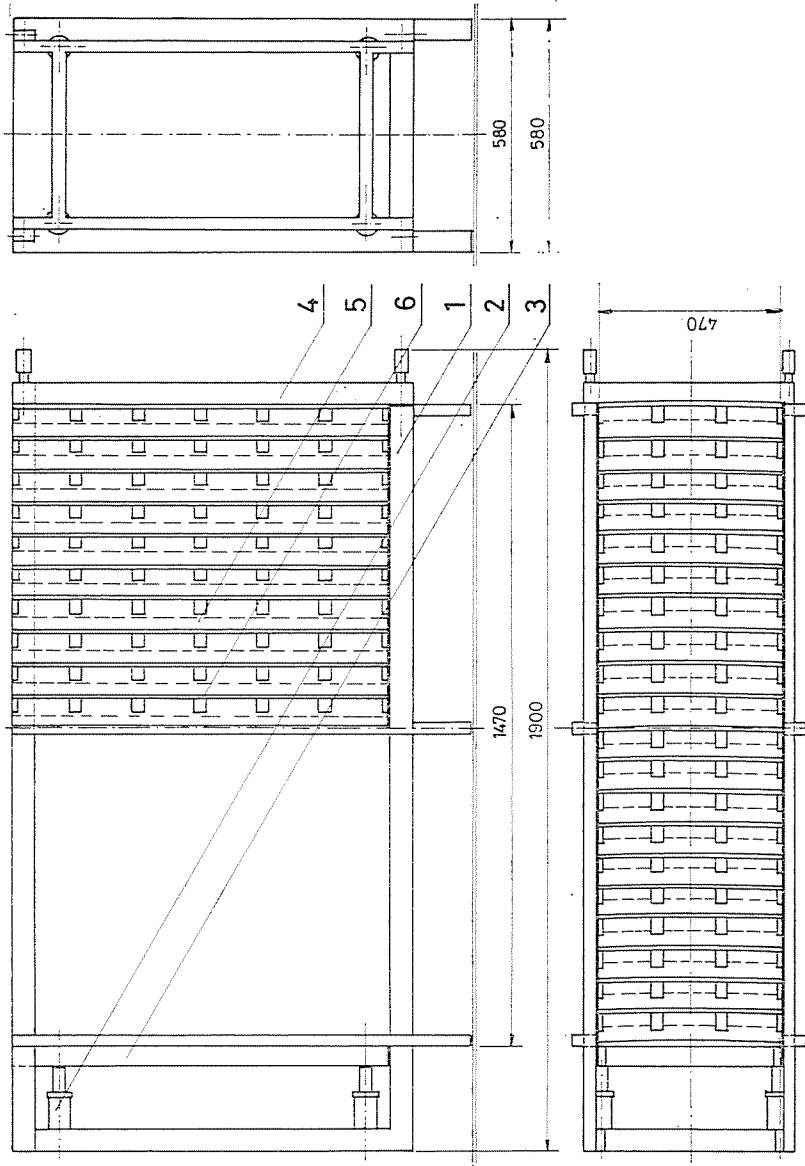

Fig. 13. Casting battery. 20 unit apparatus for manufacturing non-tectonic periodic gypsum surface elements with cylinder surface on both sides. This manufacturing apparatus occurs in the following variations: V. 1.; V. 3.; V. 4.; V. 6.; BV. 1. and BV. 3. Index: 1. Basic frame; 2. Pneumatic working cylinder to push the battery forward with one element after the other, to assure removal of the elements one by one; 3. Pressing frame covered with a steel plate; 4. Closing frame covered with a steel plate; 5. Pvc. forming plate provided with periodic holes; 6. Lamella, pvc

V. 1. Assembly

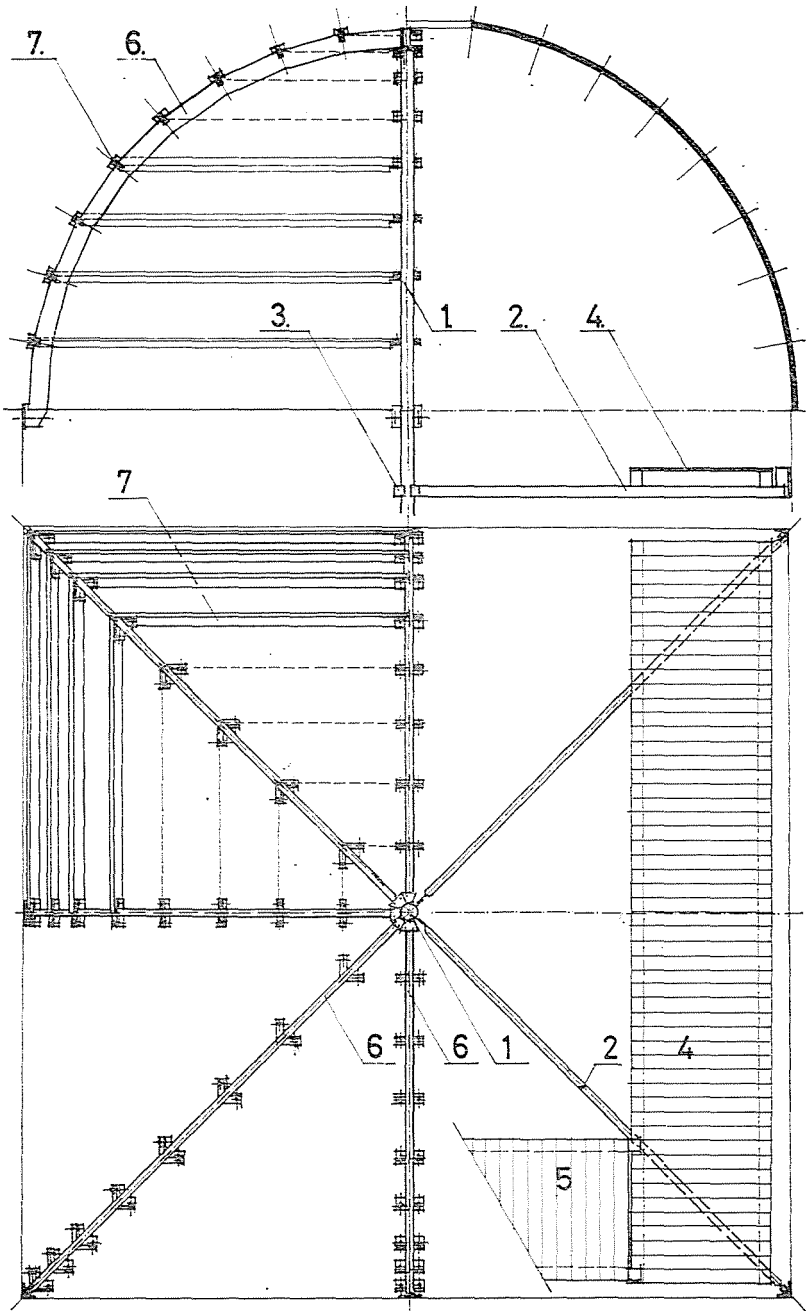

Fig. 14. Auxiliary structure for the assembly of cloister vault. Index: 1. Leading post started from the zero-level of co-ordination; 2. Stiffening and supporting rod; 3. Welded collar; 4. "Gang-way". Timber running-board supported by the diagonal stiffening rods; 5. The same, supported by the running-board 4.; Poligonal supporting arch; 7. Shuttering rods jointed to supporting arch 5

V. 2. Design

Definition of structural variation V. 2.:

Structural variation on plan and in section, on:

- an adaptation of cloister vault in the box-frame unit building method (Figs 4, 9 and 10.);
- cloister vault composed of “blindeighths” with regular polygonal meridional curve and constructed above a square;
- medium degree of complementarity (medium degree of readiness in the factory);

in the factory:

- on two-fold disintegration (Gutenberg-principled and mechanization principled decomposition);
- on preassembly of ribbed r. c. shell plane structural elements based on the additivity of non-tectonic periodic plane surface elements;

on the site:

- on location of tectonic structural elements (plane elements) in in-situ position and final pouring.

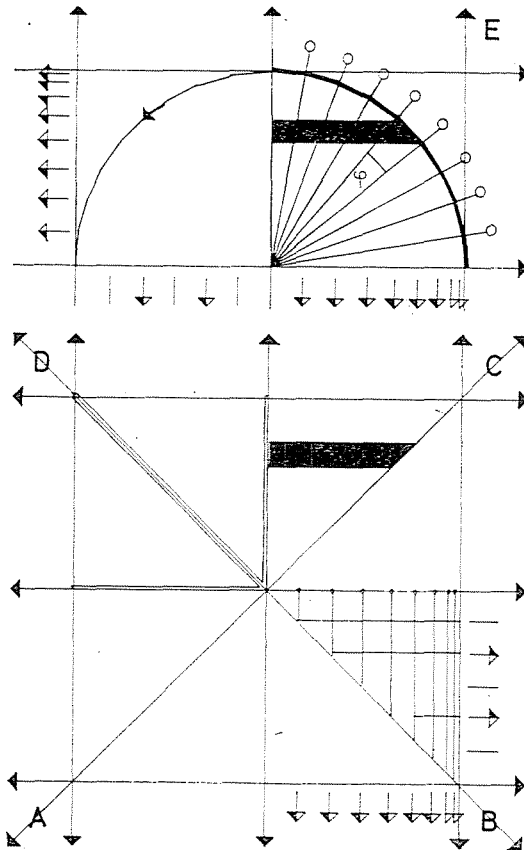

Fig. 15. The system of grids of variation V. 2. on plan and in section. Decomposition of the structure

Index: A. The system of primary grid-lines and grid-curves on plan; B. The system of secondary grid-lines on plan; C. Location of the element in the system of grids on plan; D. Location of the element of the auxiliary structure in the system of grids on plan; E. The system of primary and secondary grid-lines in section, location of the element in the system of grids in section

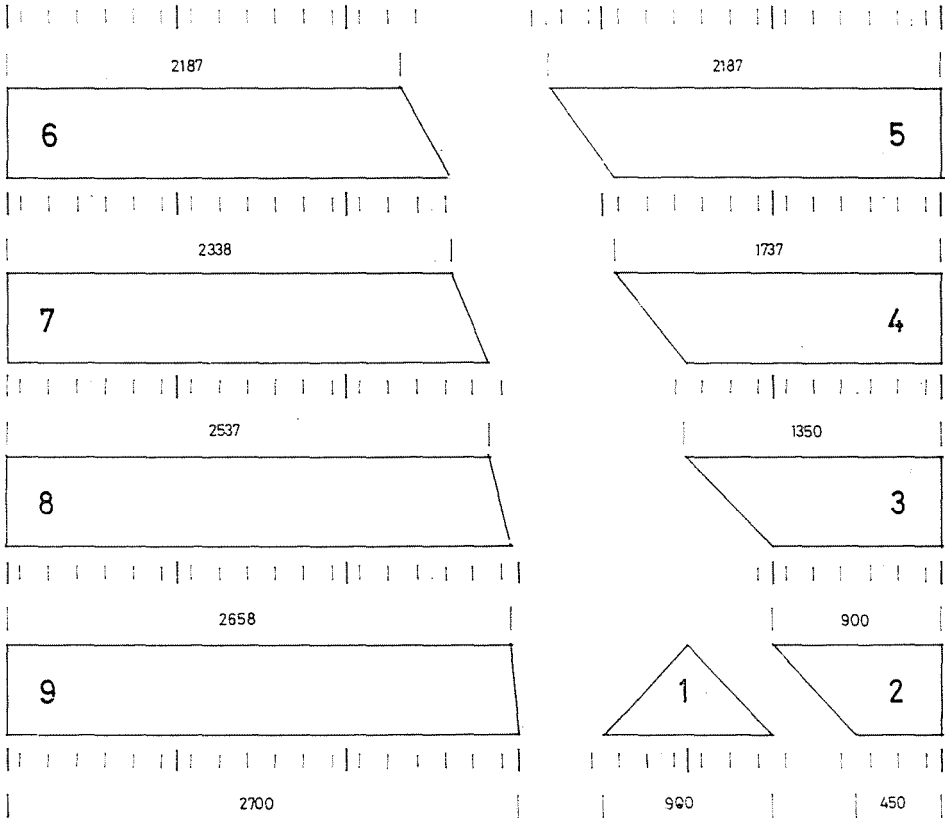
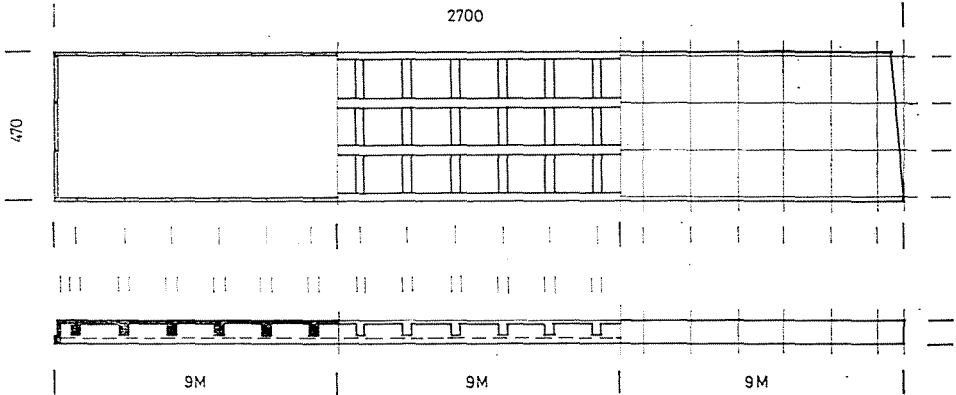

Fig. 16. Structural variation V. 2.: Basic tectonic elements (ribbed r.c. shell plane structural elements). Dimensions of the non-tectonic periodic gypsum surface elements with plane surface on both sides are identical with those of structural variation V. 1. (see: Fig. 12.)

V. 2. Manufacture

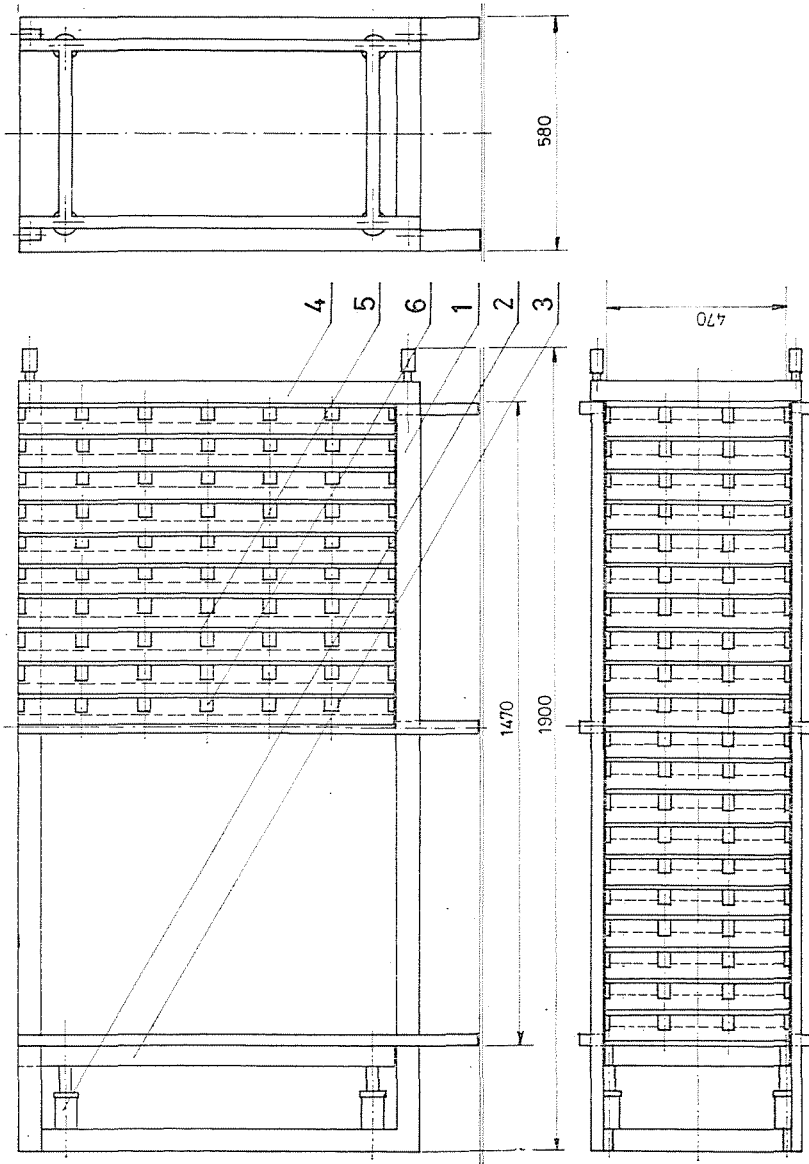

Fig. 17. Casting battery. 20 unit apparatus for manufacturing non-tectonic periodic gypsum surface elements with plane surface on both sides. Index: Basic frame; 2. Pneumatic working cylinder to push the battery forward with one element after the other, to assure removal of the elements one by one; 3. Pressing frame covered with a steel plate; 4. Closing frame covered with a steel plate; 5. Lamella, pvc; 6. Forming grid

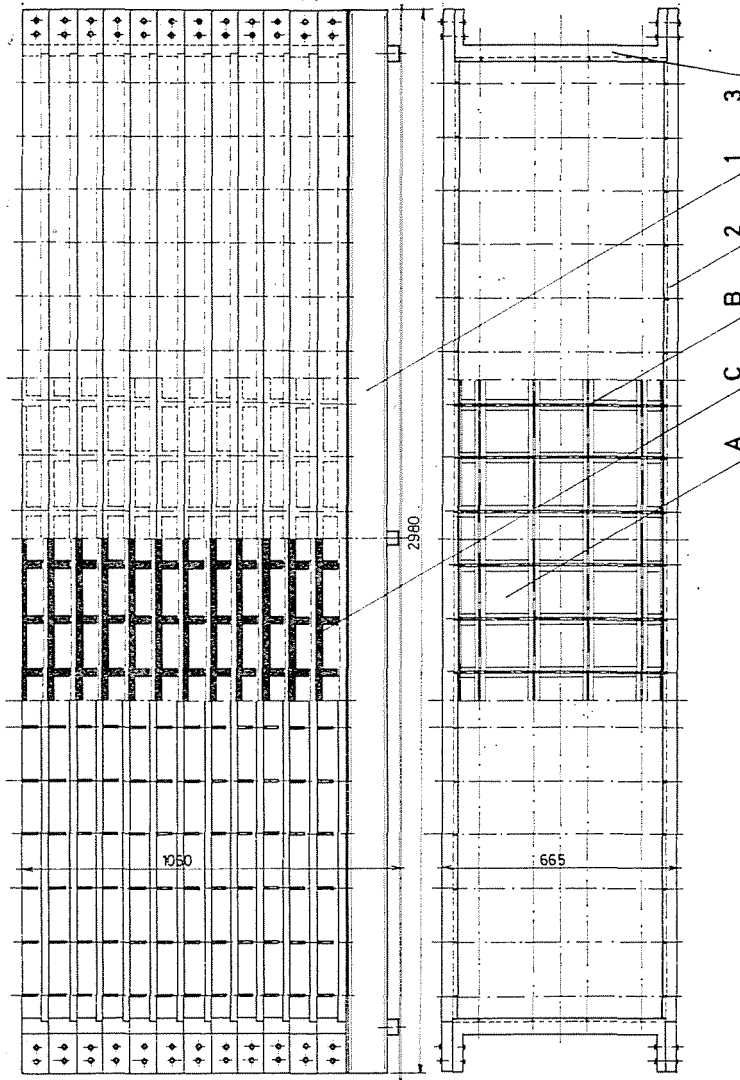

Fig. 18. Stack-plate. Manufacturing apparatus for producing ribbed r.c. shell structural elements. Index: 1. Bottom plate. 2. Longitudinal side profile; 3. Cross profile; A. The non-tectonic periodic gypsum surface element; B. Reinforcement; C. Concrete

V. 2. Assembly

The auxiliary structure applied in this case is reduced to the leading post and the polygonal supporting arches. (See also: Structural variation V. 1. Assembly; Fig. 14.)

V. 3. Design

Definition of structural variation V. 3.:

- Structural variation on plan and in section, on:
- an adaptation of cloister vault in the box-frame unit building method (Figs 4, 9 and 10.);
 - Cloister vault composed of “blind-eighths” with semicircular meridian curve and constructed above a square;
- in the factory:
- high degree of complementarity (high degree of readiness in the factory);
 - on two-fold disintegration (on Gutenberg-principled and mechanization principled decomposition);
 - on preassembly of ribbed r. c. shell structural “in space” additivity of non-tectonic elements with cylinder surface on both sides;
- on the site:
- on location of tectonic structural small space-units (“blind-eighths”) in in-situ position and final pouring.

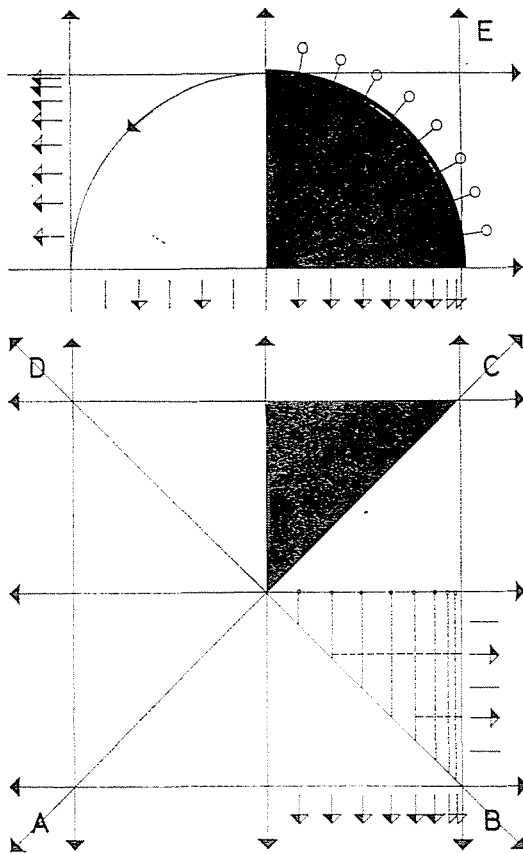

Fig. 19. The system of grids of variation V. 3. on plan and in section. Decomposition of the structure

Index: A. The system of primary grid-lines and grid-curves on plan; B. The system of secondary grid-lines on plan; C. Location of the element in the system of grids on plan; D. Location of junctions; E. The system of primary and secondary grid-lines and grid-curves in section; Location of the element in the system of grids in section

V. 3. Manufacture

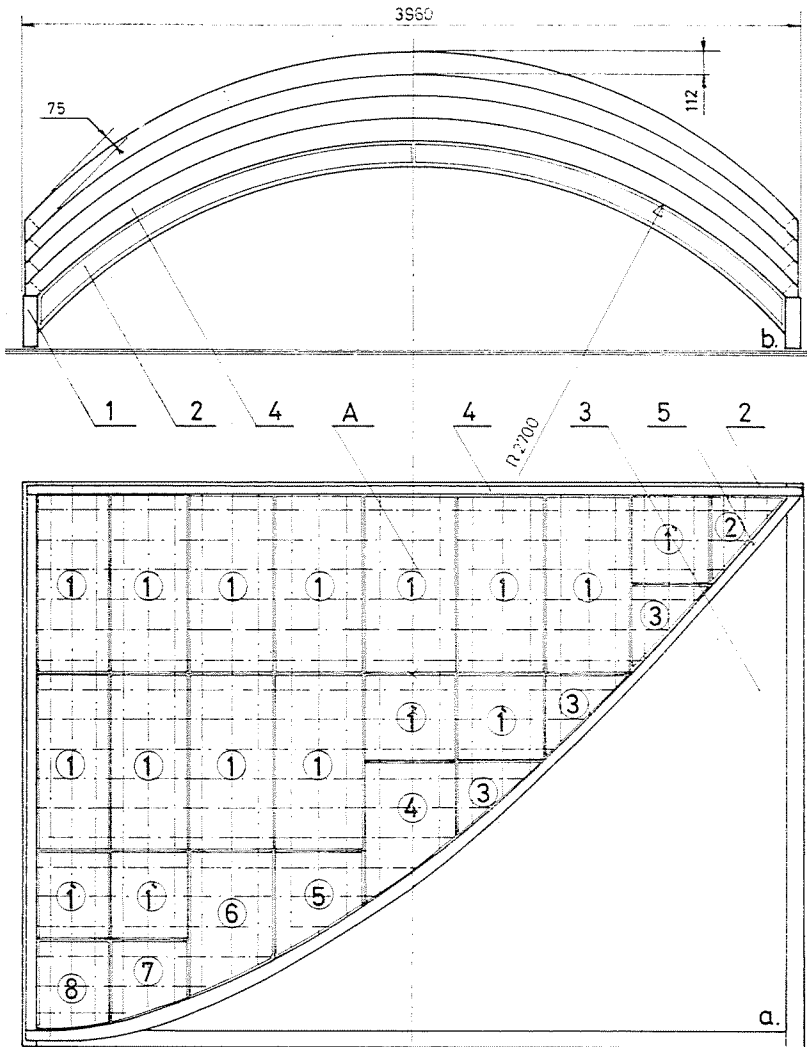

Fig. 20. Four-unit stack. Manufacturing apparatus for producing ribbed r.c. shell structural small space-units based on the "in space" additivity of non-tectonic elements with cylinder surface on both sides. Index: a. Plan; b. Section; 1. Perimeter beam of stack in the direction of the generating line; 2. Perimeter beam of stack in the direction of the meridian curve; 3. Surface of stack; the grid spacial frame is covered with a steel plate; 4. Semicircular side profile; 5. Elliptical side profile; A. Identification numbers of the non-tectonic periodic surface elements with cylinder surface on both sides; (the applied basic non-tectonic elements are illustrated in structural variation V. 1.; Fig. 12.)

V. 3. Assembly

The auxiliary structure applied in this case is practically confined to the leading post.

V. 4. Design

Definition of structural variation V. 4.:

Structural variation on plan and in section, on:

- an adaptation of cloister vault in the box-frame unit building method (Figs 4, 9 and 10.);
- cloister vault composed of “blindeighths” with semicircular meridian curve and constructed above an octagon;

in the factory:

- low degree of complementarity (low degree of readiness in the factory);
- on one-fold disintegration (on Gutenberg-principled decomposition);
- on non-tectonic elements with cylinder surface on both sides;

on the site:

- on the in-situ additivity of surface elements, (on calling into being the loadbearing structure on the building site).

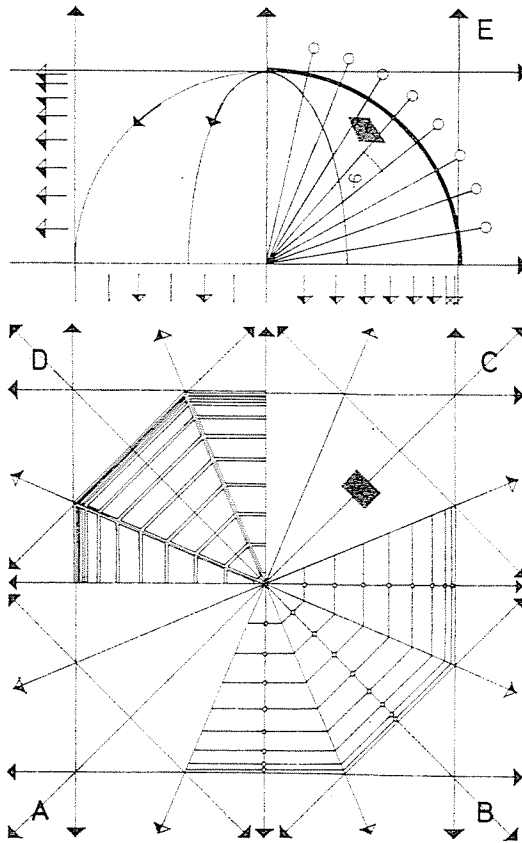

Fig. 21. The system of grids of variation V. 4. on plan and in section. Decomposition of the structure

Index: A. The system of primary grid-lines and grid-curves on plan; B. The system of secondary grid-lines and grid-curves on plan; C. Location of the element in the system of grids, on plan; D. location of the elements of the auxiliary structure in the system of grids, on plan; E. The system of primary grid-lines and grid-curves, in section; Location of the element in the system of grids, in section

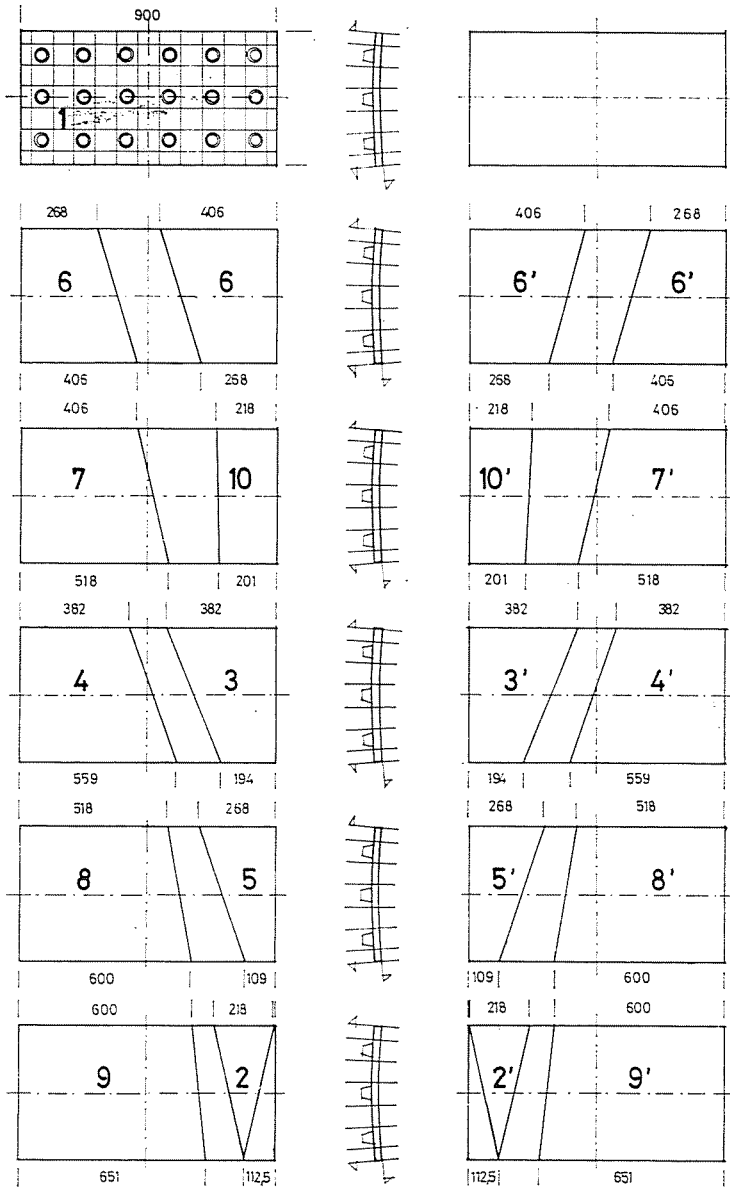

Fig. 22. Structural variation V. 4. Basic non-tectonic elements: Non-tectonic periodic gypsum surface elements with cylinder surface on both sides

V. 4. Manufacture

The manufacturing apparatus applied for producing the basic non-tectonic surface elements — the unit casting battery has already been introduced in variation V. 1. (Fig. 13.).

V. 4. Assembly

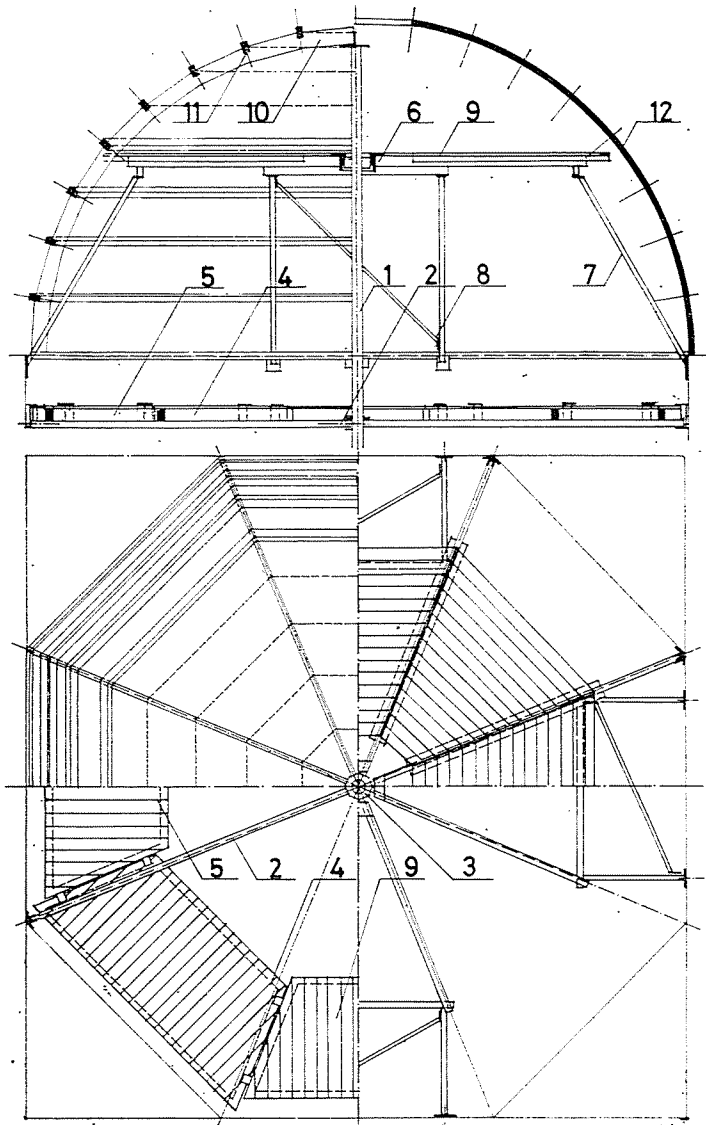

Fig. 23. Scaffolding for the erection of vault V. 4. Index: 1. Leading post started from the zero-level of co-ordination; 2. Stiffening and supporting rod jointed to leading post and to the heterogeneous jointing points underneath the springing level of vault; 3. "collar" welded to leading post; 4. "Gang-way", timber running board supported by the diagonal stiffening rod; 5. The same, supported by running folded out; 8. Stiffening rod of scaffolding frame; 9. Timber running-board; 10. Polygonal supporting arch; 11. Rods jointed to polygonal arches 10 for supporting the surface elements; 12. The finished structure

V. 5. Design

Definition of structural variation V. 5.:

Structural variation on plan and in section, on:

- an adaptation of cloister vault in the box-frame unit building method (Figs 4, 9 and 10.);
- cloister vault composed of “blindeights” with regular polygonal merid-ian curve and constructed above an octagon;
- medium degree of complementarity (medium degree of readiness in the factory);

in the factory:

- on two-fold disintegration (Gutenberg-principled and mechanization principled decomposition);
- on preassembly of ribbed r. c. shell plane structural elements with plane surface on both sides;

on the site:

- on location of tectonic structural elements (plane elements) in in-situ position and final pouring.

Fig. 24. The system of grids of varia-tion V. 5. on plan and in section. Decomposition of the structure

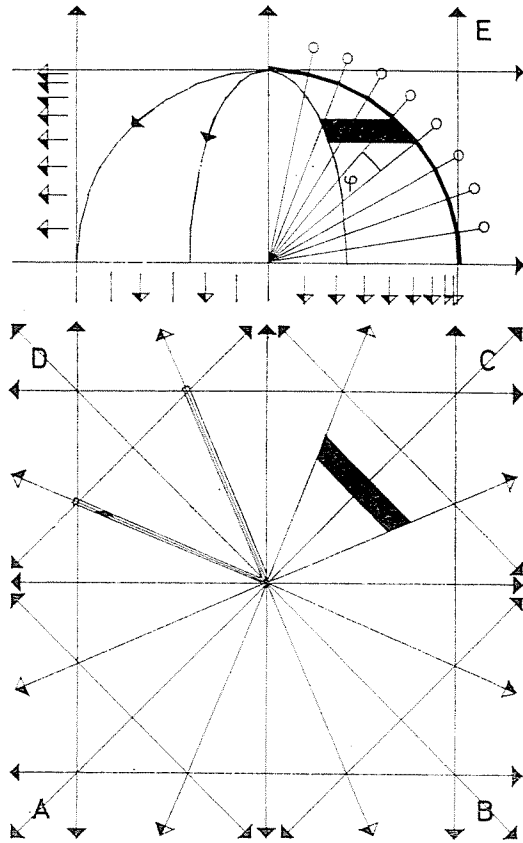

Index: A. The system of primary grid-lines and grid-curves on plan; B. The system of secondary grid-lines on plan; C. Location of the element in the system of grids on plan; D. Location of the element of the auxiliary structure in the system of grids on plan; E. The system of primary and secondary grid-lines in section, the location of the element in the system of grids in section

V. 5. Manufacture and V. 5. Assembly

The problems of manufacture and assembly here are completely identical with those of varia-tion V. 2.

V. 6. Design

Definition of structural variation V. 6.:

Structural variation on plan and in section, on:

- an adaptation of cloister vault in the box-frame unit building method (Figs 4, 9 and 10.);
- cloister vault composed of “blind-eighths” with semicircular meridian curve and constructed above an octagon;
- high degree of complementarity (high degree of readiness in the factory);
- in the factory:
 - on two-fold disintegration (on Gutenberg-principled and mechanization-principled decomposition);
 - on preassembly of ribbed r.c. shell structural small space-units based on the “in space” additivity of nontectonic elements with cylinder surface on both sides;
- on the-site:
 - on location of tectonic structural small space-units (“blind-eighths”) in in-situ position and final pouring.

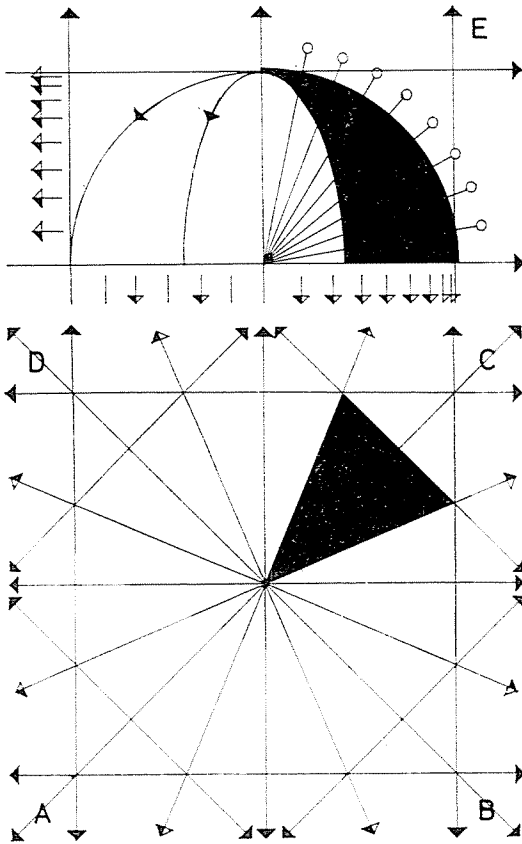

Fig. 25. The system of grids of variation V. 6. on plan and in section. Decomposition of the structure

Index: A. The system of primary grid-lines and grid-curves on plan; B. The system of secondary grid-lines and grid-curves on plan; C. Location of the element in the system of grids, on plan; D. Location of junctions; E. The system of primary grid-lines and grid-curves, in section; Location of the element in the system of grids, in section

V. 6. Manufacture and v. 6. Assembly

The problems of manufacture and assembly here are completely identical with those of variation V. 3.

Section 3

Domes (D): Structural variations on the adaptation of domes in the closed cellular building method, on low, medium and high degree of complementarity

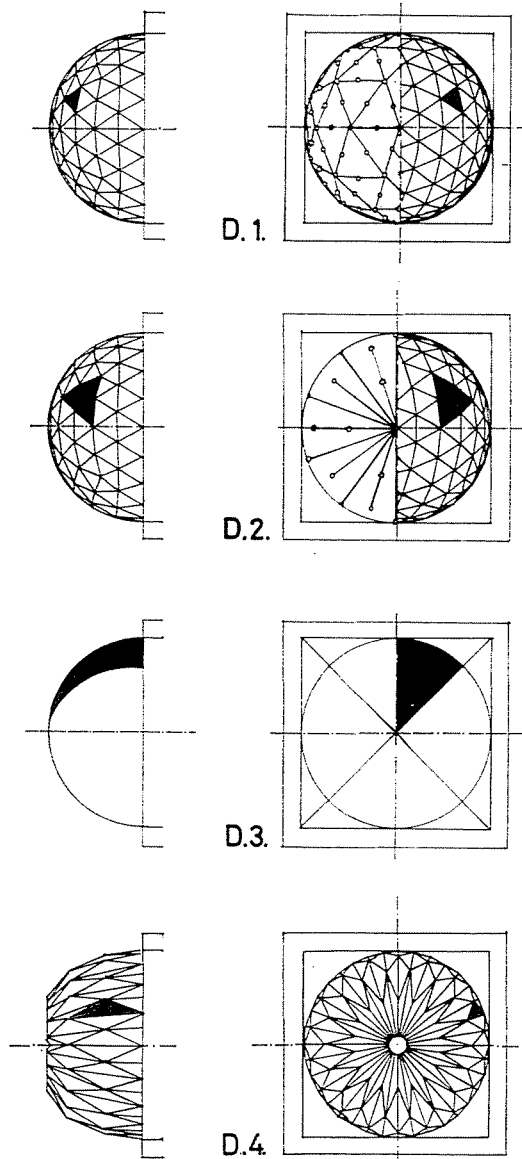

Fig. 26. Introduction of the structural variations D. 1. — D. 4. Each variation will be analysed in three consecutive steps corresponding to the phases of design — manufacture — assembly. Short definitions and drawings put the emphasis on illustrating the principles

Adaptations of domes in the closed-cellular building method*

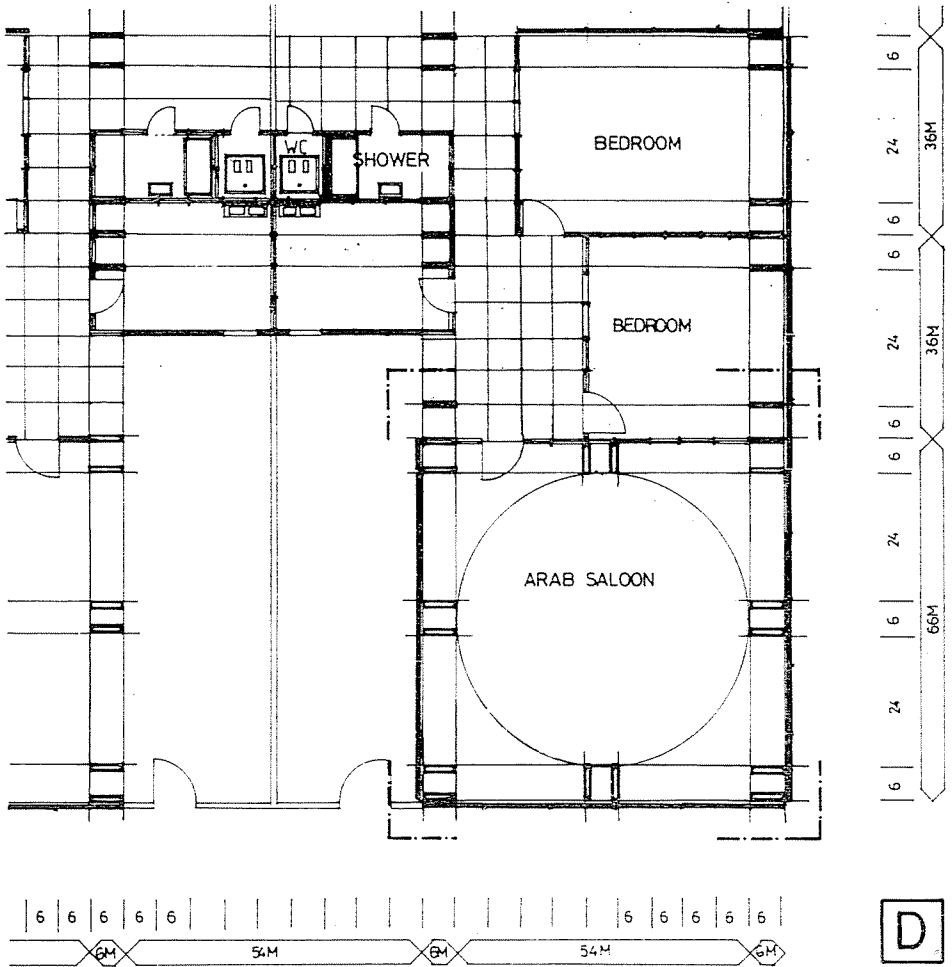

Fig. 27. Location of the domed space in the ground plan. From the methodological point of view the adaptation of domes can most expediently be demonstrated in central-symmetrical arrangements. For this purpose the span dimension (54M) is kept constant, the o/a dimensions of pillar-box-frames (6M × 6M; 6M × 12M; 6M × 12M + mc) are variable but they always fit into the 6M zone. Characteristic problems of co-ordination always arise where the one-directional zone of the closed cellular floor-fields meet the central-symmetrical area of the dome, as illustrated by Fig. 28

* The closed cellular building method (see: Fig. 5.) was treated in detail in a previous study (see: Ref. 14.); therefore, here (Fig. 27. and Fig. 28.) only the most general aspects are demonstrated: the place of the domed space on plan and in section and its location in the system of grids.

The system of grids

Lines of the *primary grid on plan* determine the location of the pillar box-frames and the beam box-frames and, finally, the location of the dome itself. The grid dimensions are as follows:

$6M$ = width of pillar box-frames and beam box-frames
 $54M = 9 \times 6M$ = span

Lines of the *primary grid in section* determine the following planes:

the zero level of co-ordination: ($\pm 0.00m$);
 the lower level of beam box-frame ($+ 2.40m$);
 the upper level of beam box-frame: ($+ 3.00m$);
 the springing level of dome ($+ 3.00m$).

This means that the upper level of the closed cellular floors is not a co-ordination level.

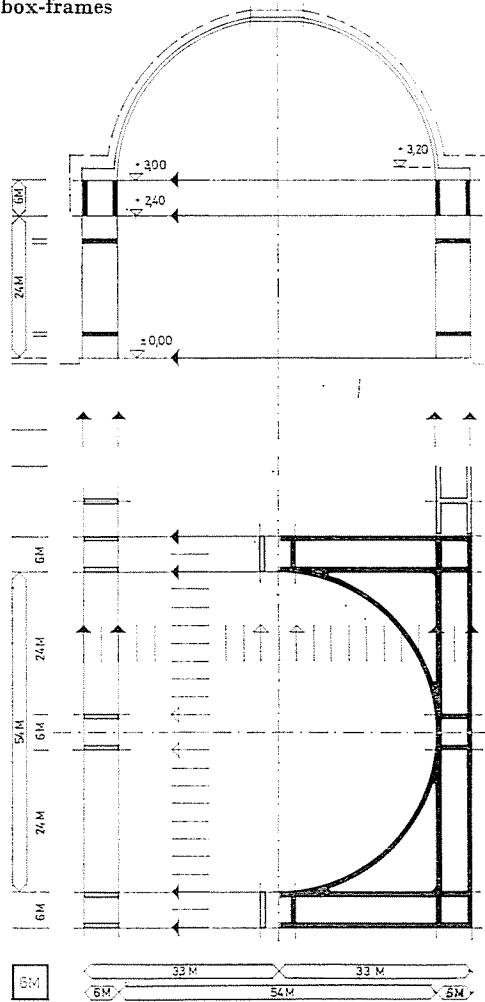

Fig. 28. Location of the domed space in the system of grids on plan and in section. The elements of the dome — the non-tectonic surface elements, the tectonic structural elements, etc. — are always introduced with the respective structural variations

In the zone of the rooms the $54M \times 18M$ dimensions of the closed cellular floor elements remained the same; In the central-symmetrical domed space the pillar box-frames and the beam box-frames keep station within the primary grid system (which establishes a face-line reference both on plan and in section.)

The adaptation — i.e.: the linking of these two parts — can be realized without problem.

Adaptation of domes: Geometrical method of the sphere-approach

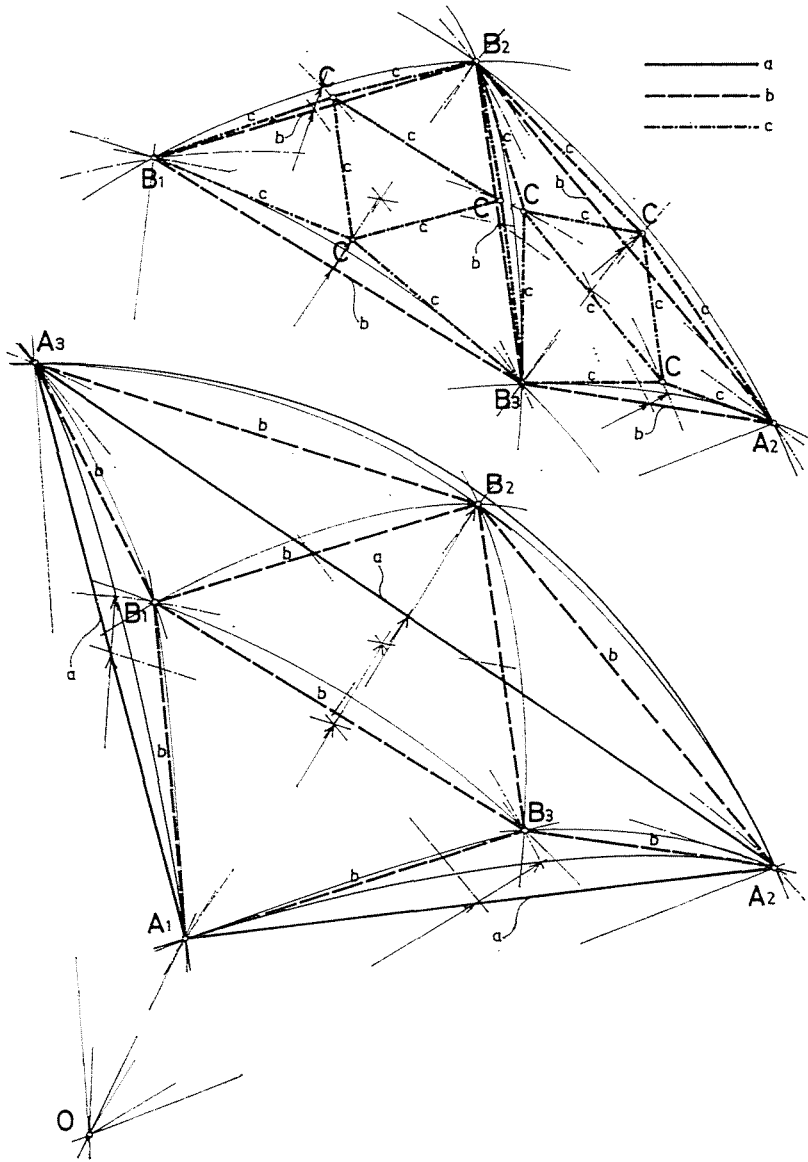

Fig. 29. Geometrical method of the sphere-approach. $A_1 A_2 A_3$ equilateral triangle is a face of an icosahedron; "a" the edge of the icosahedron; "o" the central point of the sphere enveloping the icosahedron. $B_1 B_2$ and B_3 are points of the sphere situated on the bisectrices of $A_1 A_2 A_3$ spherical triangle. If we connect these points with each other and with the vertices of the spherical triangle we get a network composed of strings "b". If such a network is constructed on each face of the icosahedron, then, it results in a sphere-approach composed of 80 equilateral triangles and 30 "diamonds". Now, if we repeat this operation on the spherical triangles of this network then, finally, we get a network composed of strings "c" and it results in a sphere-approach composed of 320 equilateral triangles plus small triangles and trapeziums

D. 1. Design

Definition of structural variation D. 1.:

Structural variation on plan and in section, on:

- an adaptation of semispherical dome in the closed cellular building method (Figs 5, 27, 28.);
- a sphere-approach with 320 faces starting out from icosahedron (Fig. 29.);

in the factory:

- low degree of complementarity (low degree of readiness in the factory);
- on one-fold disintegration (on Gutenberg-principled decomposition);
- on non-tectonic elements with spherical surface on both sides;

on the site:

- on the in-situ additivity of surface elements, (on calling into being the loadbearing structure on the building site).

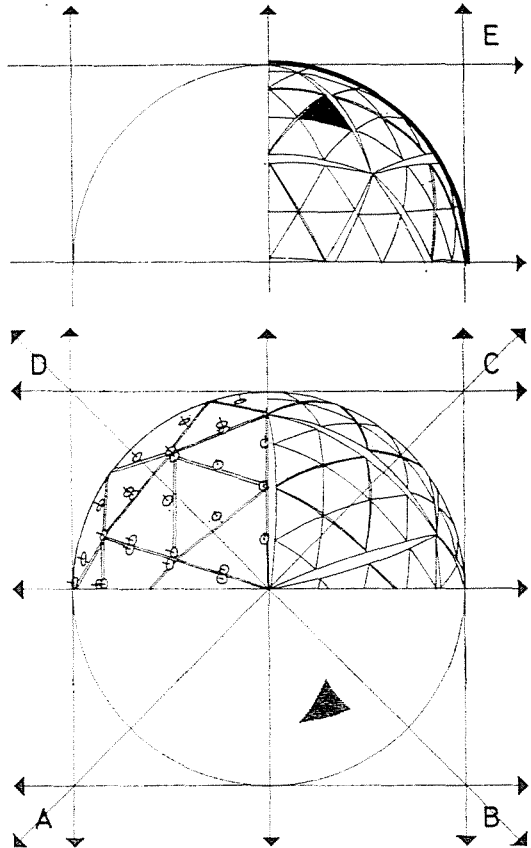
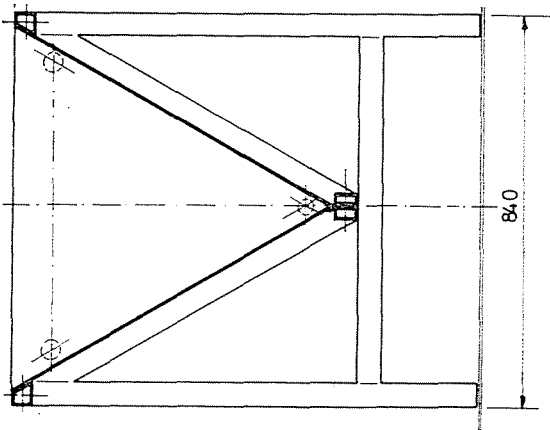

Fig. 30. The system of grids of variation D. 1. on plan and in section.
Decomposition of the structure

Index: A; C; E. The system of primary grid-lines and secondary grid-curves on plan and section; B. Location of the surface element in the system of grids; D. Location of the elements of the auxiliary structure in the system of grids



D. 1. Manufacture

Index: 1. Basic frame; 2. Closing frame covered with a steel plate; 3. Pressing frame covered with a steel plate; 4. Hydraulic working cylinder to push the battery forward with one element after the other, to assure removal of elements one by one; 5. Pvc. forming plate provided with periodic holes; 6. Separating lamella, pvc

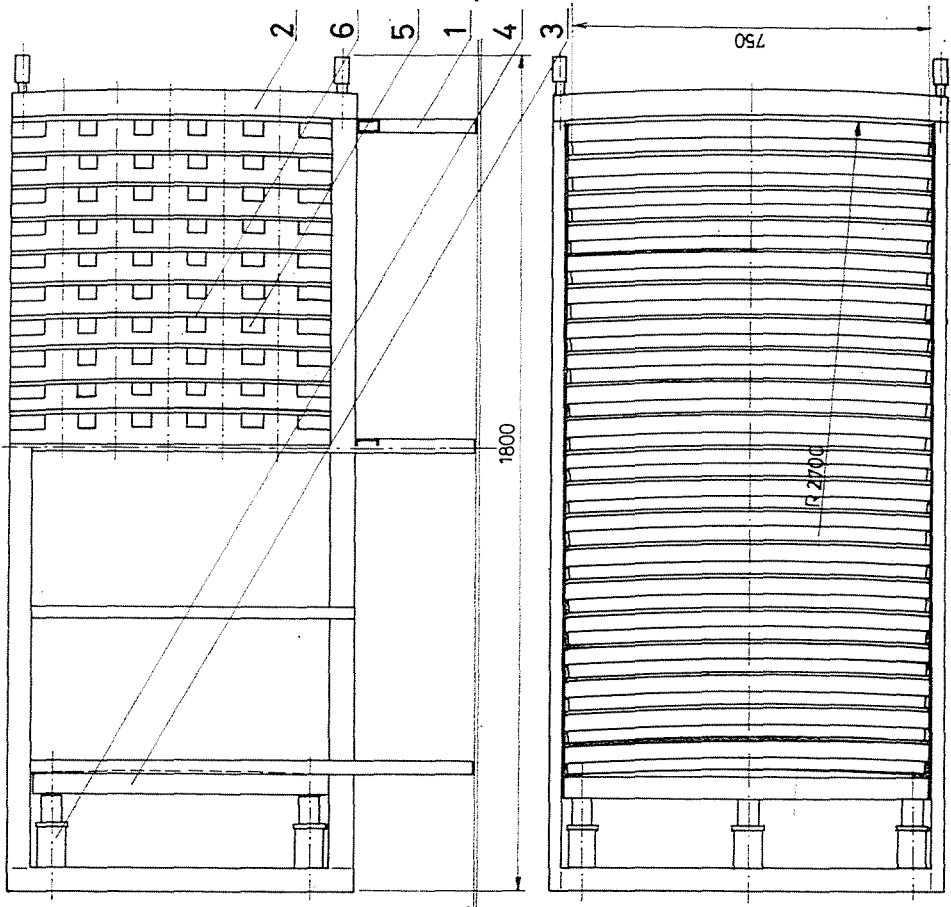

Fig. 31. Casting battery. 20 unit apparatus for manufacturing non-tectonic periodic gypsum surface elements with spherical surface on both sides.

D. 1. Assembly

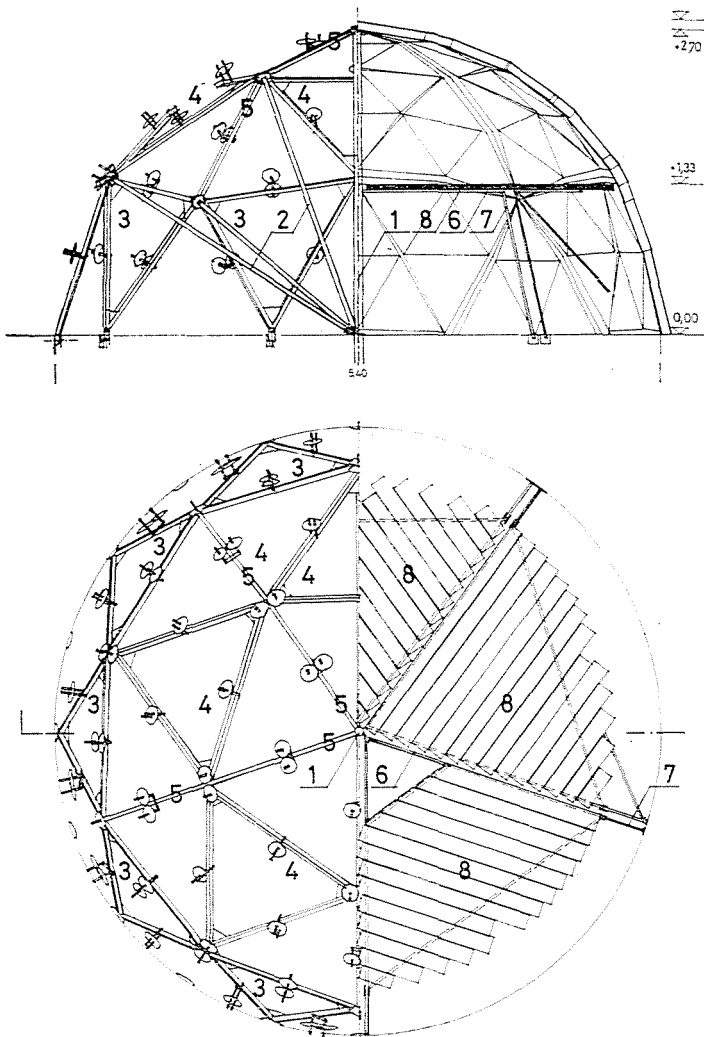

Fig. 32. Auxiliary structure and scaffolding for the assembly of the non-tectonic surface elements of variation D. 1. and for erection of the dome. Index: 1. Leading post started from the zero-level of co-ordination; 2. Stiffening radial etalon rods jointed to "collar" welded to leading post; 3, 4. Triangular elements of the auxiliary structure of different dimensions to point out location of the surface element and for supporting; 5. Linear elements of the auxiliary structure for the same purpose; 6. Scaffolding frame; 7. Leg of scaffolding frame folded out; 8. Timber running-board

D. 2. Design

Definition of structural variation D. 2.:

Structural variation on plan and in section, on:

- an adaptation of semispherical dome in the closed cellular building method (Figs 5, 27, 28.);
- a sphere approach with 320 faces starting out from icosahedron (Fig. 29.);
- medium degree of complementarity (medium degree of-readiness in the factory);

in the factory:

- on two-fold disintegration (Gutenberg-principled and mechanization principled decomposition);
- on preassembly of ribbed r.c. shell structural small space-units based on the "in-space" additivity of nontectonic periodic plane surface elements;

on the site:

- on location of tectonic structural elements (small space-units) in in-situ position and final pouring.

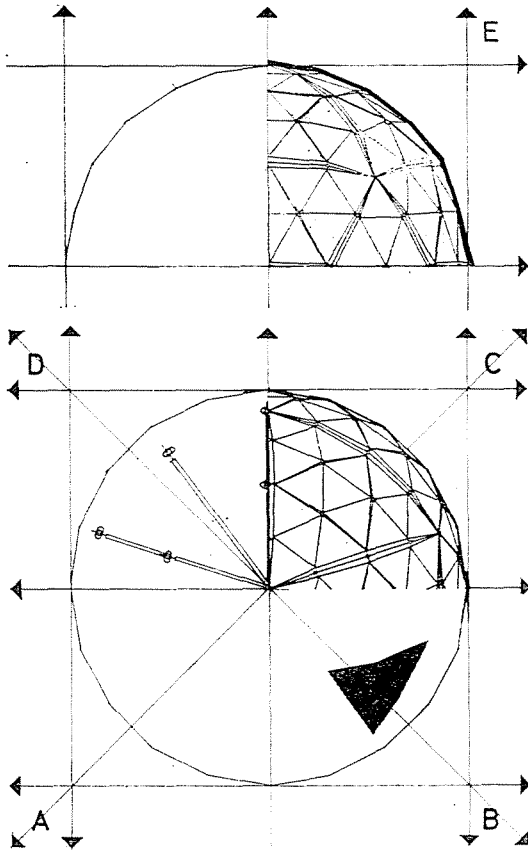

Fig. 33. The system of grids of variation D. 2. on plan and in section. Decomposition of the structure

Index: A; C; E. The system of primary and secondary grid-lines on plan and in section; B. Location of the tectonic structural element in the system of grids; D. Location of the elements of the auxiliary structure in the system of grids

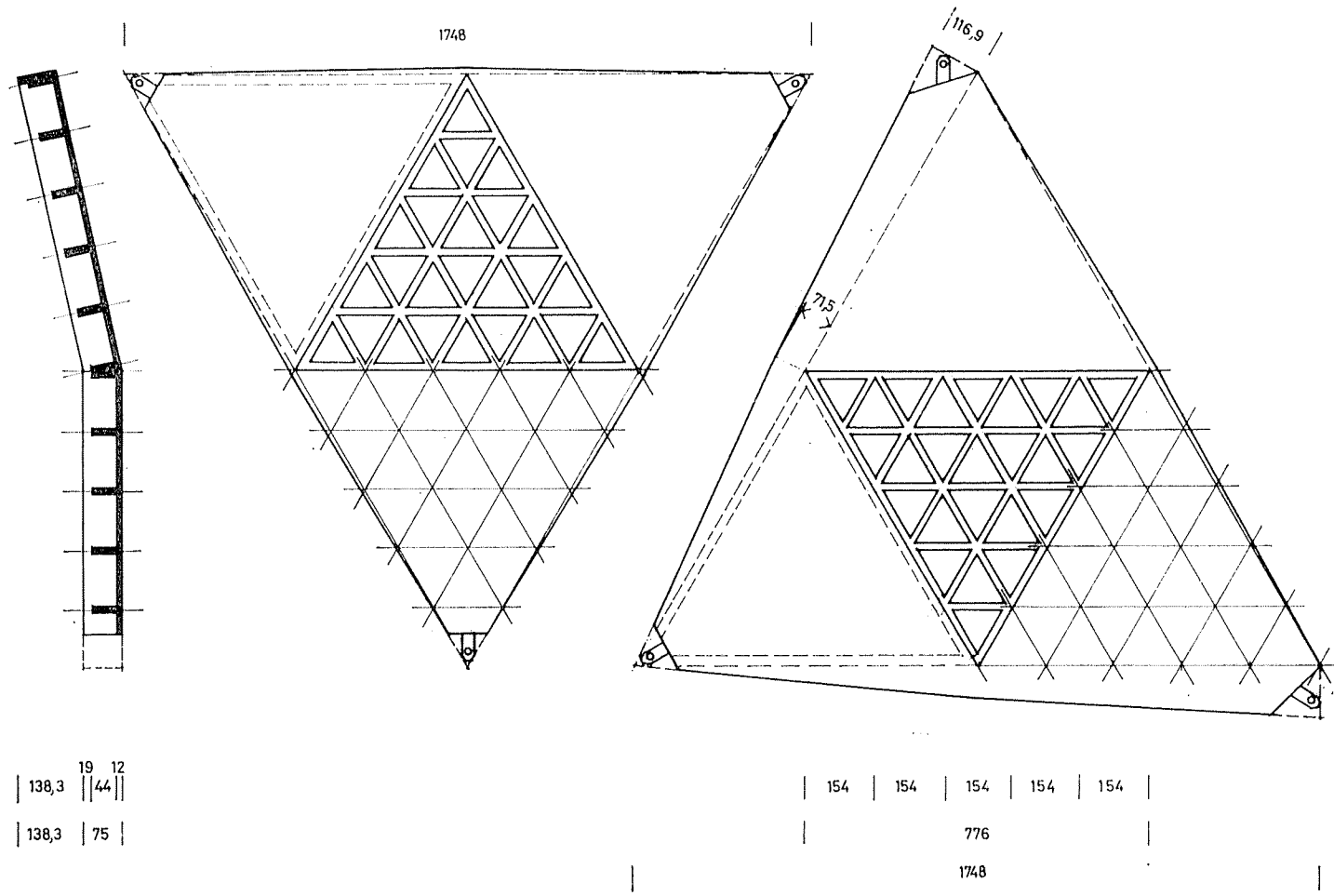

Fig. 34. Structural variation D. 2.: Basic non-tectonic and tectonic elements: The non-tectonic periodic triangular gypsum surface element (with plane surface on both sides) and the ribbed and folded r.c. shell structural small space-unit based on the "in-space" additivity of the non-tectonic periodic plane surface elements

D. 2. Manufacture

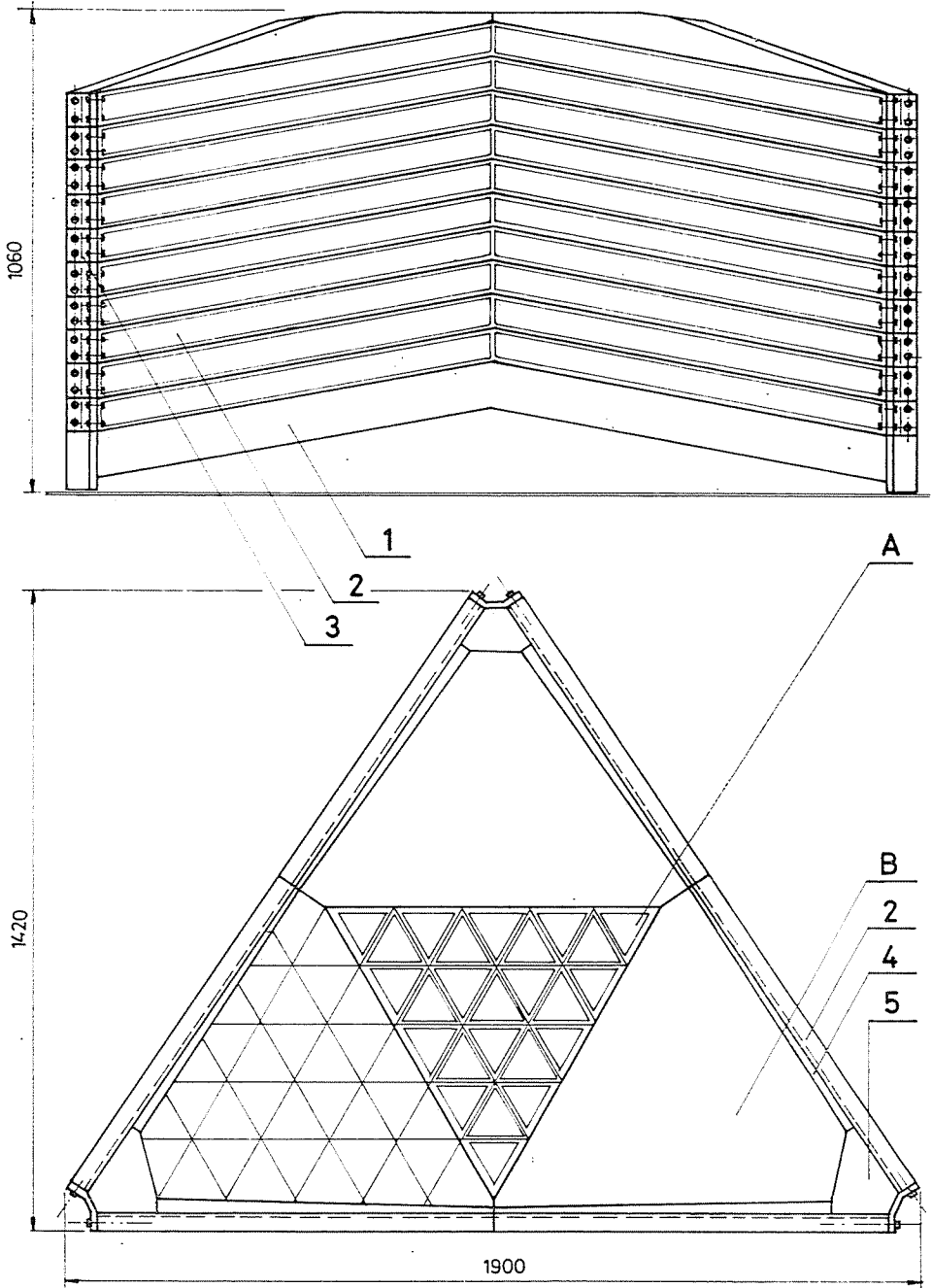

Fig. 35. Ten-unit stack. Manufacturing apparatus for producing ribbed and folded r. c. shell structural small space-units based on the "in-space additivity of non-tectonic elements with plane surface on both sides. Index: 1. Bottom plate; 2. Side profile; 3. Corner element fixing the side; profiles by pairs; 4. Removable inlay pieces for producing elements of different dimensions 5. Inlay element: blocking piece; A. The non-tectonic surface element; B. The concreted small space unit

D. 2. Assembly

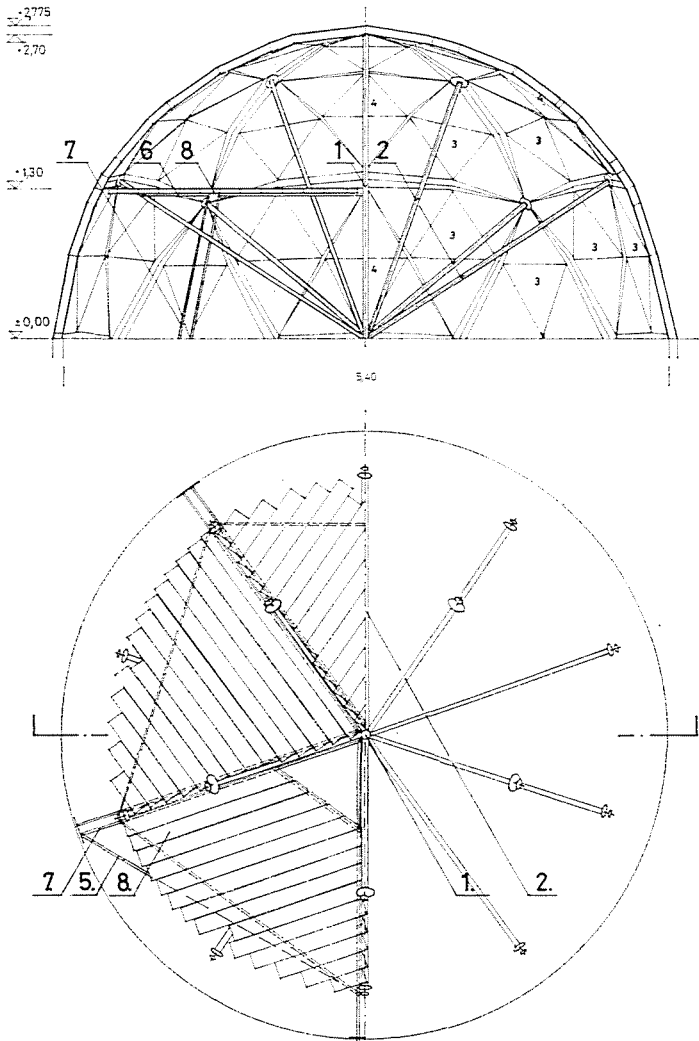

Fig. 36. Auxiliary structure and scaffolding for the assembly of the tectonic structural elements of variation D. 2. and for the erection of the dome. In this case the auxiliary structure serves for pointing out the location of the ribbed and folded r. c. shell small space-units and for supporting them until final pouring is completed. Index: 1. Leading post started from the zero level of coordination; 2. Stiffening radial etalon rods jointed to the "collar" of the leading post; 3.—4. Structural small space-units of different dimensions; 5. Stiffening rod of scaffolding frame; 6. Scaffolding frame; 7. Leg of scaffolding frame folded out; 8. Timber running-board

D. 3. Design

Definition of structural variation D. 3.:

Structural variation on plan and in section, on:

— an adaptation of semispherical dome in the closed cellular building method (Figs 5, 27, 28.);

— 45° spherical slices;

in the factory:

— high degree of complementarity (high degree of readiness in the factory);

— on two-fold disintegration (Gutenberg-principled and mechanization principled decomposition);

on the site:

— on location of tectonic structural small space-units (i.e.: tectonic structural r.c. membrane elements (based on the "in-space" additivity of non-tectonic elements with spherical surface on both sides);

— on location of tectonic structural small space-units (45s spherical slices) in in-situ position and final pouring.

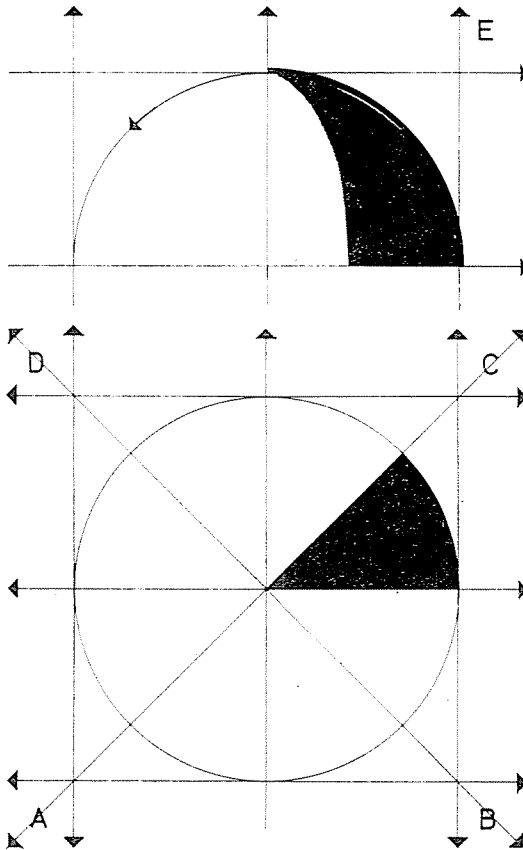

Fig. 37. The system of grids of variation D. 3. on plan and in section. Decomposition of the structure

Index: A; B; D; The system of primary grid-lines and secondary grid-curves on plan and in section; C; E. Location of the tectonic structural element in the system of grids on plan and in section

D. 3. Manufacture

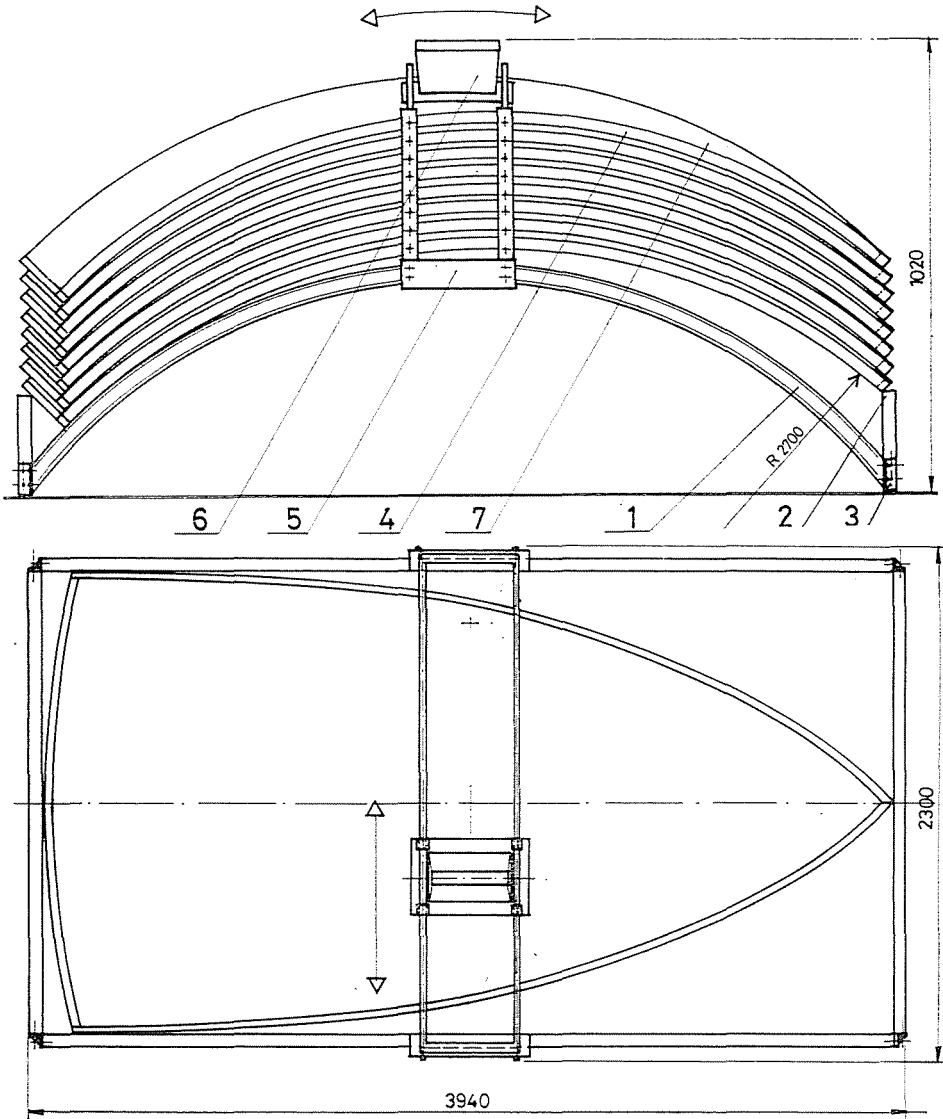

Fig. 38. Eight-unit stack. Manufacturing apparatus for producing r. c. shell structural small space-units on top of nontectonic elements with spherical surface on both sides. Index: 1; 2. Circular perimeter beams of the stack-plate; 3. Jointing piece; 4. Side profile; 5. Smoothing bridge moving on circular track; 6. Spherical smoothing plate supplied with a filling throat

D. 3. Assembly

The problems of assembly in this case are essentially identical with those of variation V. 3.

D. 4. Design

Definition of structural variation D. 4.:

Structural variation on plan and in section, on:

- an adaptation of folded shell dome in the closed cellular building method (Figs 5, 27, 28.), constructed above a circle;
- medium degree of complementarity (medium degree of readiness in the factory);

in the factory:

- on two-fold disintegration (Gutenberg-principled and mechanization principled decomposition);
- on preassembly of ribbed r.c. shell plane structural elements based on the additivity of non-tectonic periodic-plane surface elements;

on the site:

- on location of tectonic structural elements (plane elements) in in-situ position and final pouring.

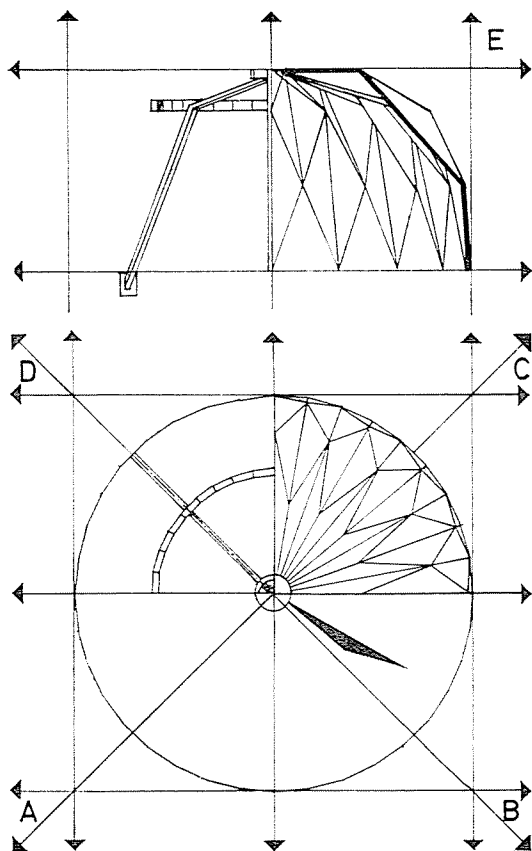

Fig. 39. The system of grids of variation D. 4. on plan and in section. Decomposition of the structure

Index: A; C; E. The system of primary and secondary gridlines on plan and in section; B. Location of the tectonic plane structural element in the system of grids; D. Location of the elements of the auxiliary structure in the system of grids

D. 4. Manufacture

The manufacture of the applied non-tectonic surface elements is essentially identical with the manufacture of the surface elements used for variation V. 2. Basically the same applies for the production of the tectonic structural elements, i.e. the ribbed r. c. shell plane elements.

D. 4. Assembly

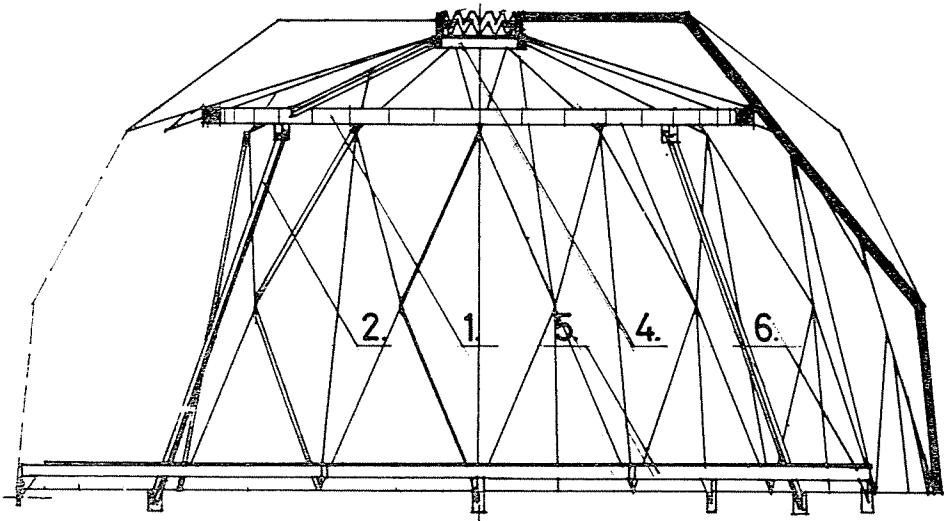

Fig. 40a. Auxiliary structure and scaffolding for the assembly of the tectonic plane structural elements of variation D. 4. and for the erection of the folded shell dome (Section). In this case again the auxiliary structure serves for pointing out the location of the ribbed r. c. shell plane structural elements and for supporting them until final homogeneous junction is completed. Index 1. Polygonal supporting ring; 2. Legs of the supporting ring folded out; 3. Stiffening rod of the supporting ring; 4. Roof-light ("opeion") element; 5. Scaffolding frame; 6. Timber running-board

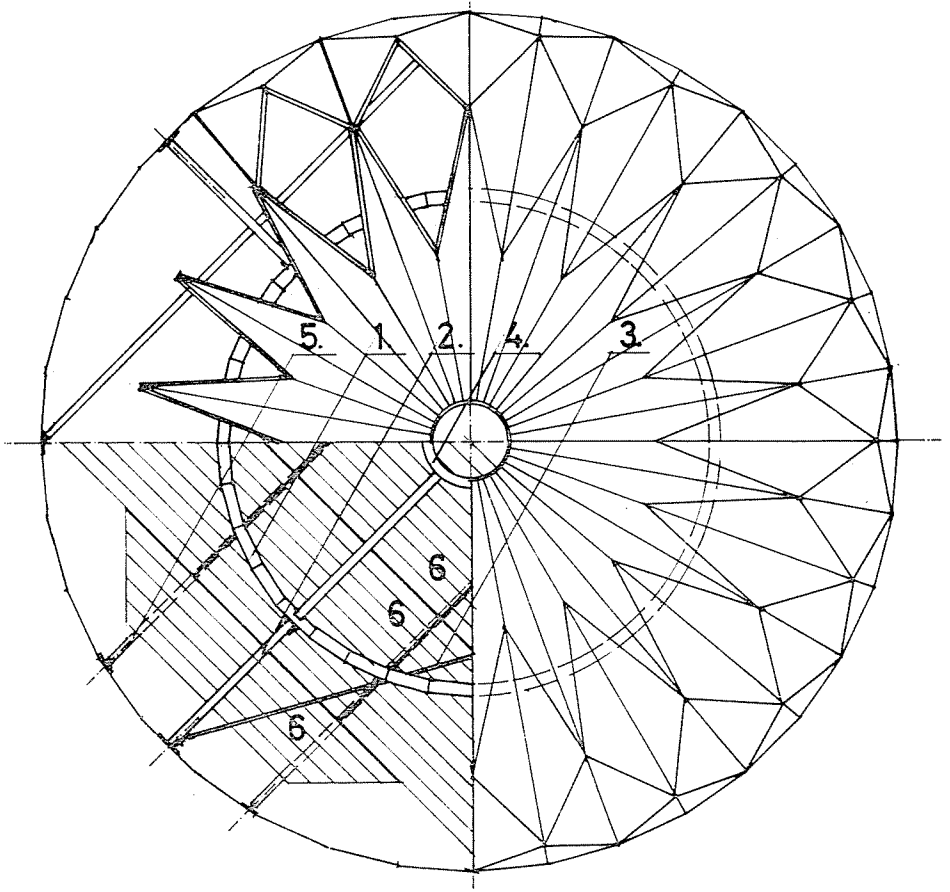

Fig. 40b. Auxiliary structure and scaffolding for the assembly of the tectonic plane structural elements of variation D. 4. and for the direction of the folded shell dome (Plan). In this case again the auxiliary structure serves for pointing out the location of the ribbed r. c. shell plane structural elements and for supporting them until final homogeneous junction is completed. Index: 1. Polygonal supporting ring; 2. Legs of the supporting ring folded out; 3. Stiffening rod of the supporting ring; 4. Roof-light ("opeon") element; 5. Scaffolding frame; 6. Timber running-board

Section 4

Barrel-vaults (BV.): Structural variations on the adaptation of barrel-vaults in the “tilt-lift” building method, on low, medium and high degree complementarity

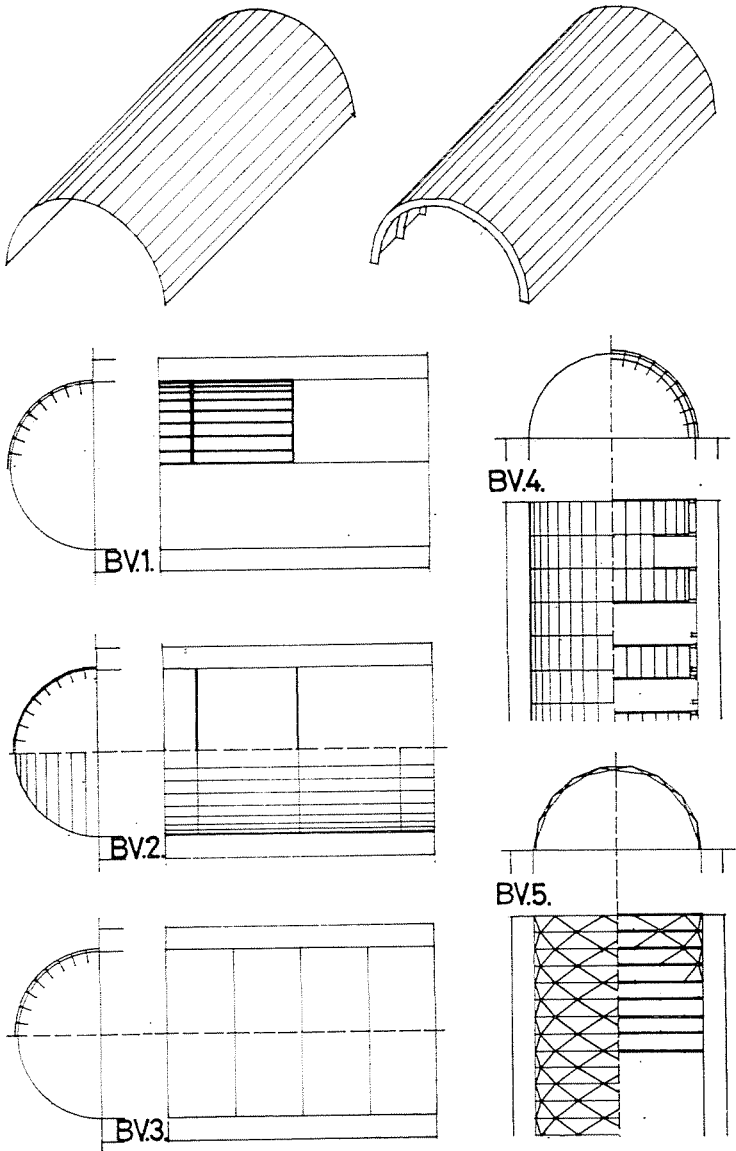

Fig. 41. Introduction of the structural variations BV. 1. — BV. 5. Each variation is expounded in three steps corresponding to the phases of design — manufacture — assembly. The short definition and drawings put the emphasis on illustrating the principles

Adaptation of barrel-vaults in the tilt-lift building method*

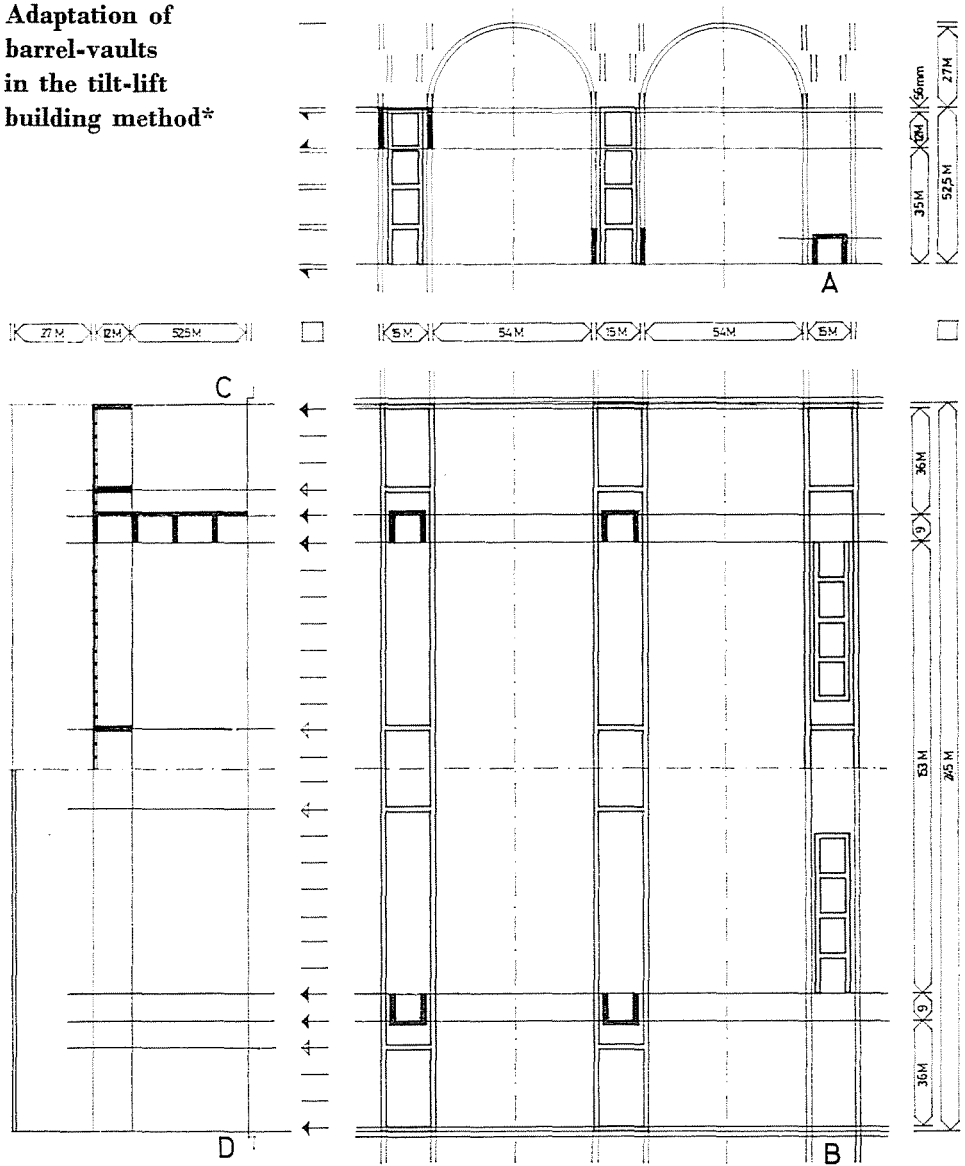

Fig. 42. Location of the barrel-vaulted space in the ground plan and in section. From the methodological point of view the adaptation of barrel-vaults can most expediently be demonstrated if constructed above unbroken longitudinal arrangements and this is why our choice fell on the industrial workshop realized by the tilt-lift building method. Figure 42. and Fig. 43 show a repetitive structural unit on plan and in section. Index: A. Cross-sections, situations prior to and after tilting and lifting; B. Plan. Situations prior to and after tilting and lifting; C. Longitudinal section through beam box-frame; D. Longitudinal section through barrel-vault

* The tilt-lift building method (see: Fig. 7) was analysed in detail in the preceding study (see: Ref. 16), therefore, here (Fig. 42 and Fig. 43) only the most general aspects are demonstrated: the place of the barrel-vaulted space on plan and in section and its location in the system of grids.

The system of grids

Lines of the *primary grid on plan* create a composite grid. Characteristic grid dimensions are as follows:

- 12M = width of pillar box-frame;
- 15M = interior dimension of beam box-frame;
- 18M = exterior dimension of beam box-frame;
- 54M = span of barrel-vault;
- 57M = distance between adjacent beam box-frames;

Lines of the *primary grid in section* determine the following levels:

- the zero-level of co-ordination: $\pm 0.00\text{m}$
- lower level of beam: $\pm 3.90\text{m}$
- upper level of pillar: $\pm 5.10\text{m}$
- springing level of barrel-vault: $\pm 5.25\text{m}$

The springing level (i.e.: the co-ordination level) of the vault is determined by the upper level of the ribbed r.c. shell floor supported by the lifted beam box-frames. The centre-lines of the ribs fit on the 9M monotonous tertiary grid. In case of ribbed barrel-vaults this grid determines at the same time the centre-lines of the ribs of the barrel-vaults, as well.

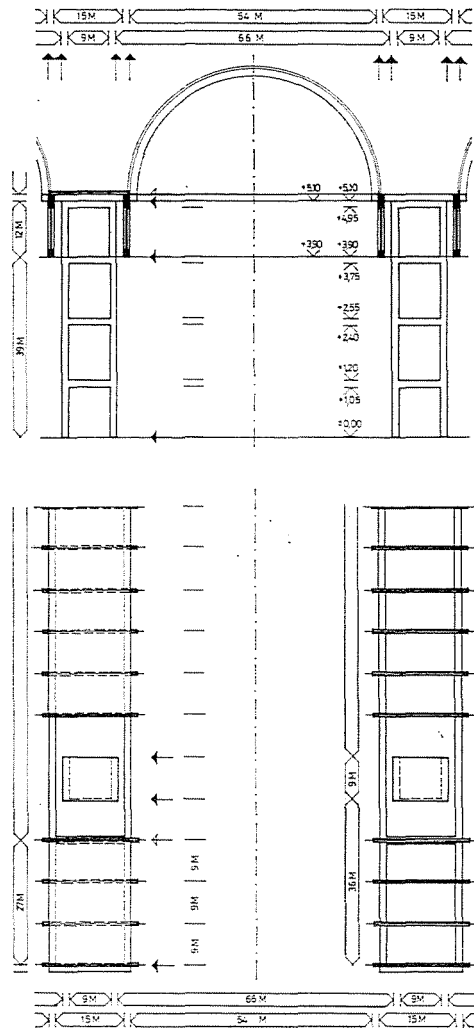

Fig. 43. Location of the barrel-vaulted space in the system of grids on plan and in section. The elements of the barrel-vaults — the non-tectonic surface elements, the tectonic structural elements — are introduced with the respective structural variations

BV. 1. Design

Definition of structural variation BV. 1.:

Structural variation on plan and in section, on:

- an adaptation of barrel-vault in the tilt-lift building method (Figs 7, 42, 43);
 - barrel-vault composed of units with semicircular meridian curve and constructed above a rectangle;
 - low degree of complementarity (low degree of readiness in the factory);
- in the factory:
- on one-fold disintegration (on Gutenberg-principled decomposition);
 - on non-tectonic elements with cylinder surface on both sides;
- on the site:
- on the in-situ additivity of surface elements, (on calling into being the loadbearing structure on the building site).

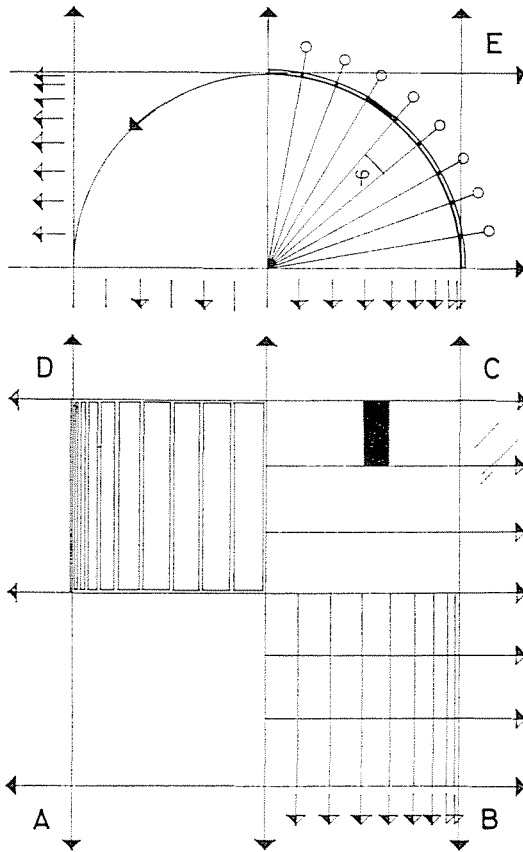

Fig. 44. The system of grids of variation BV. 1. on plan and in section. Decomposition of the structure

Index: A. The system of primary grid-lines on plan; B. The system of primary and secondary grid-lines and grid-curves on plan; C. Location of the element in the system of grids on plan; D. Location of the elements of the auxiliary structure in the system of grids on plan; E. The system of primary and secondary grid-lines and grid-curves in section; location of the element in the system of grids in section

Manufacture BV. 1. and Assembly BV. 1.:

The problems here are essentially identical with those of structural variation V. 1.

BV. 2. Design

Definition of structural variation BV. 2.:

Structural variation on plan and in section on:

- an adaptation of barrel-vault in the tilt-lift building method (Figs 7, 42, 43);
- barrel-vault composed of units with regular polygonal meridian curve and constructed above a rectangle;
- medium degree of complementarity (medium degree of readiness in the factory);

in the factory:

- on two-fold disintegration (on Gutenberg-principled and mechanization-principled decomposition);
- on preassembly of ribbed r.c. shell plane structural elements based on the additivity of non-tectonic elements with plane surface on both sides;

on the site:

- on location of tectonic structural elements (plane elements) in in-situ position and final pouring.

Fig. 45. The system of grids of variation BV. 2. on plan and in section.
Decomposition of the structure

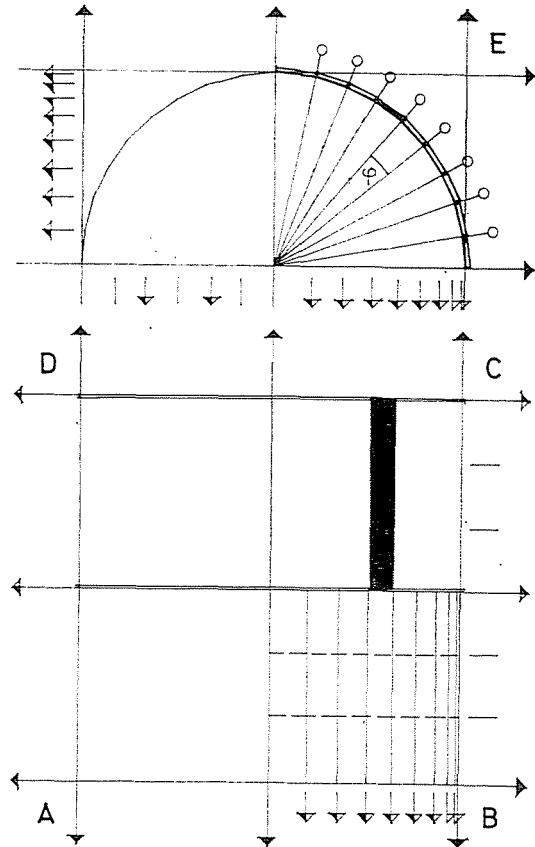

Index: A. The system of primary grid-lines on plan; B. The system of primary and secondary grid-lines on plan; C. Location of the element in the system of grids on plan; D. Location of the elements of the auxiliary structure in the system of grids on plan; E. The system of primary and secondary grid-lines in section; location of the element in section

Manufacture BV. 2. and Assembly BV. 2.:

The problems here are essentially identical with those of structural variation V. 2.

BV. 3. Design

Definition of structural variation BV. 3.:

Structural variation on plan and in section, on:

- an adaptation of barrel-vault in the tilt-lift building method (Figs 7, 42, 43);
- barrel-vault composed of units with semicircular meridian curve and constructed above a rectangle;

in the factory:

- high degree of complementarity (high degree of readiness in the factory);
- on two-fold disintegration (on Gutenberg-principled and mechanization-principled decomposition);
- on pressembly of ribbed r.c. shell structural small space-units based on the "in space" additivity of non-tectonic elements with cylinder surface on both sides;

on the site:

- on location of tectonic structural small space-units in in-situ position and final pouring.

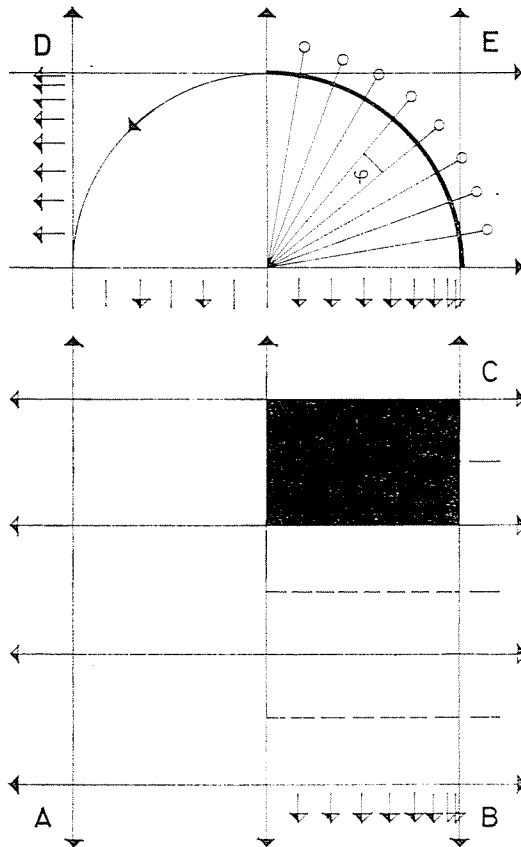

Fig. 46. The system of grids of variation BV. 3. on plan and in section. Decomposition of the structure

Index: A. The system of primary grid-lines and grid-curves on plan; B. The system of primary and secondary grid-lines and grid-curves on plan. C. Location of the element in the system of grids on plan; D. The system of primary and secondary grid-lines and grid-curves in section; E. Location of the element in the system of grids in section

Manufacture BV. 3. and Assembly BV. 3.

The problems here are essentially identical with those of structural variation V. 3.

BV. 4. Design

Definition of structural variation BV. 4.:

Structural variation on plan and in section, on:

- an adaptation of barrel-vault in the tilt-lift building method (Figs 7, 42, 43);
- barrel-vault composed of units with regular polygonal meridian curve, constructed above a rectangle and rigidified with regular polygonal ribs at right angle to the axis;
- medium degree of complementarity (medium degree of readiness in the factory);

in the factory:

- on one-fold disintegration (on Gutenberg-principled decomposition);

on the site:

- on preassembly of plane structure elements;
- on location of plane structure elements in in-situ position, or, underneath in-situ position;
- on preassembly of ribbed barrel-vault units underneath in-situ position,
- on (calling into being the loadbearing structure on the building site).

Fig. 47. The system of grids of variation BV. 4. on plan and in section.
Decomposition of the structure

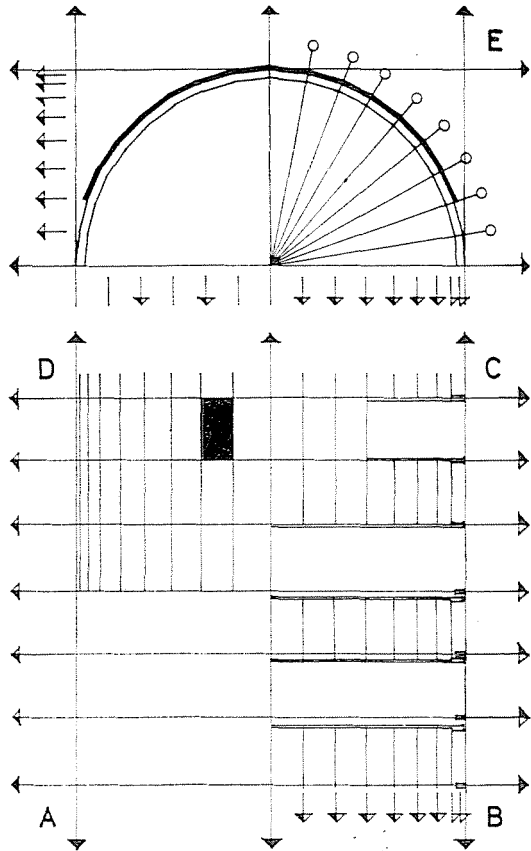

Index: A. The system of primary and secondary grid-lines on plan; B. Pre-assembly of the ribbed barrel-vault units on zero-level of co-ordination, underneath in-situ position, in the situation prior to lifting; C. The assembly of the barrel-vault after the lifting of the ribbed barrel-vault units; D. Location of the tectonic plane element in the system of grids on plan; E. Location of the element in the system of grids in section

BV. 5. Design

Definition of structural variation BV. 5.:

Structural variation on plan and in section, on:

- an adaptation of folded shell barrel-vault in the tilt-lift building method (Figs 7, 42, 43);
- barrel-vault composed of r.c. folded shell units with regular polygonal meridian curve, constructed above a rectangle;
- medium degree of complementarity (medium degree of readiness in the factory);

in the factory:

- on two-fold disintegration (on Gutenberg-principled and mechanization-principled decomposition);
- on preassembly of ribbed r.c. shell structural plane elements based on the "in-plane" additivity of non-tectonic plane surface elements;

on the site:

- on location of tectonic plane structural elements in in-situ position and final pouring.

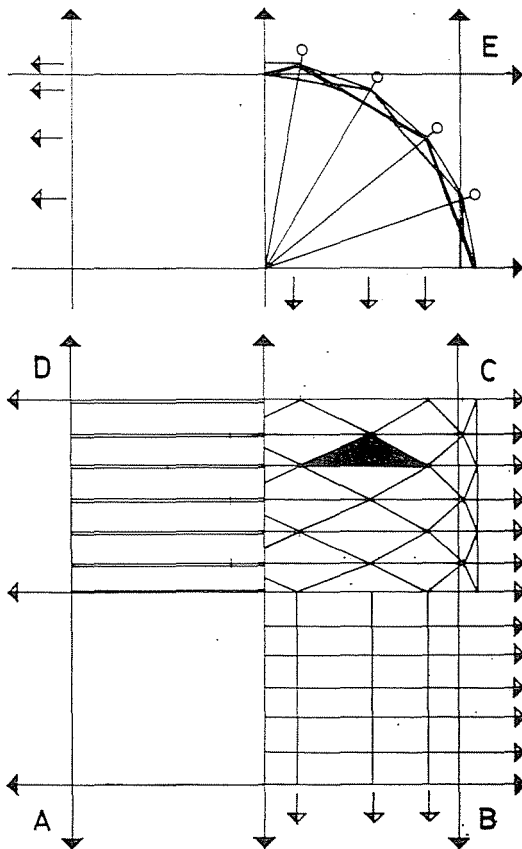

Fig. 48. The system of grids of variation BV. 5. on plan and in section. Decomposition of the structure

Index: A; B. The system of primary and secondary grid-lines on plan; C. Location of the tectonic plane element in the system of grids on plan; D. Location of the elements of the auxiliary structure in the system of grids on plan; E. The system of primary and secondary grid-lines in section

BV. 5. Manufacture

The manufacture of the applied non-tectonic surface elements is identical with the manufacture of surface elements in case of structural variation V. 2. The problem of producing ribbed r.c. shell structural plane elements are again identical with those of structural variation V. 2.

BV. 5. Assembly

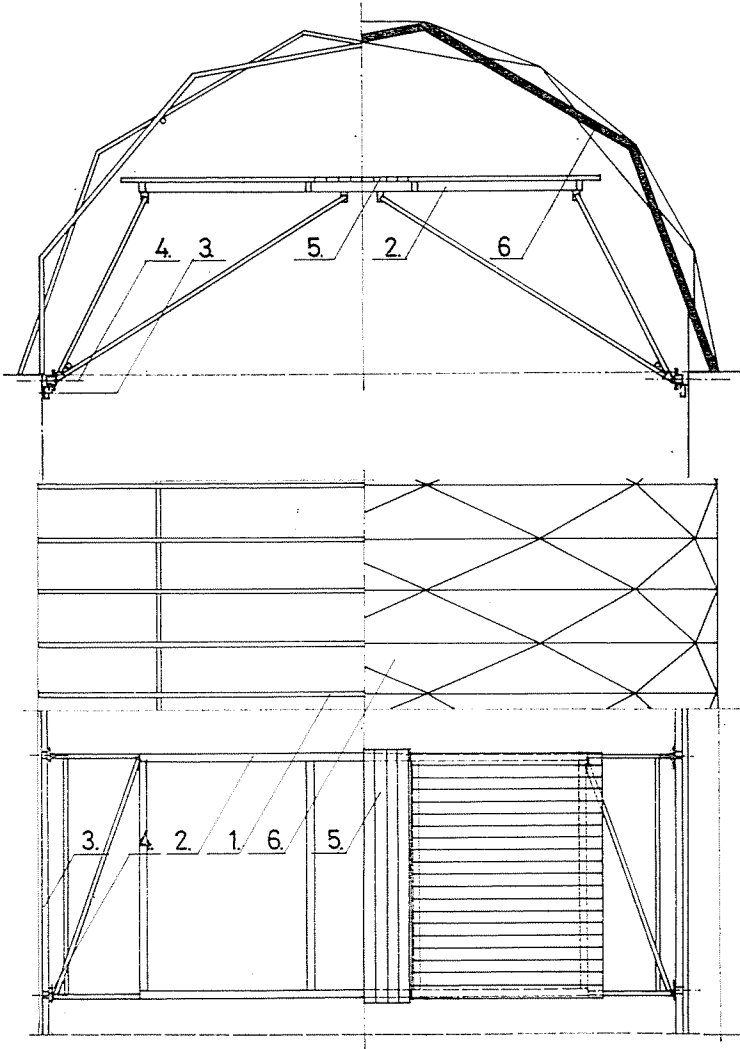

Fig. 49. BV. 5. Assembly: rolling scaffolding and auxiliary structure to point out the position of the ribbed r. c. shell plane structural elements and to support them in in-situ position until final pouring. Index: 1. Polygonal supporting arch; 2. Scaffolding frame; 3. Rail, fixed to the structure under the springing level of the folded shell barrel-vault; 4. Roller; 5. Gang-way: timber running-board
6. The completed structure

References

The publications enumerated below are only those immediately related to the subject matter.

1. PÁRKÁNYI, M.: The Inherent Contradictions of the Closed Systems of Prefabrication and the Future. Trends of Evolution. Contribution at the third CIB Congress. Published in "Towards Industrialized Building", Elsevier Publishing Company Amsterdam 1965.
2. PÁRKÁNYI, M.: Prefabrication with Gypsum. Meeting on Prefabrication in Africa and the Middle East. 17—29 April 1972 Budapest, Hungary; Bucharest, Roumania, ID/WG 122/20 March 1972 pp. 5
3. PÁRKÁNYI, M.: Non-tectonic Systems. *Periodica Politechnica. Architecture*. Vol. 17. No. 4. 1973. pp. 122—165.
4. PÁRKÁNYI, M.: Experimental Non-tectonic Maisonette. *Per. Pol. Arch.* Vol. 18, No. 3—4. pp. 189—214.
5. GARAY, L., PÁRKÁNYI, M.: Trends Towards Synthesis in Structural Engineering. CIB 6th Congress, Budapest, 1974. Subject Theme II/3. pp. 453—463.
6. PÁRKÁNYI, M.: Final Report of the Expert on Manufacture of Prefabricated Gypsum Wall Panels, Somalia February 1974. Manuscript. Prepared for UNIDO 70. pp. Restricted.
7. PÁRKÁNYI, M.: "Lift-field" Experimental Non-tectonic Hall. *Per. Pol. Arch.* Vol. 22. No. 1. 1978. pp. 21—48.
8. PÁRKÁNYI, M.: Proposition for a Building Technology for Mass Housing in Subtropical or Arid Tropical Areas. CIB 6th Congress, 1974 Budapest, Subject Theme VI/2. Discussion. pp. 406—407. Elsevier Publishing Company. Amsterdam 1976.
9. Non-tectonic System developed. *UNIDO Newsletter*, 132 (1979) April pp. 2—3. Vienna, Austria.
10. PÁRKÁNYI, M.: Non-Tectonic Systems. An Illustrated Report of the Lightweight Silicate-Based Heat Storing Building Systems. *Acta Technica Academiae Scientiarum Hungaricae*, Tomus 92 (1—2. pp. 89—120 (1981).
11. PÁRKÁNYI, M.—HAJDU, L.—BARCZA, J.—KÖVESDI, R.—SZIRMAI, Z.: Feasibility study. An Adaptation of the Non-Tectonic System to the People's Democratic Republic of Yemen. pp. 107. Restricted. Budapest 1981.
12. GÁBOR, L.—PÁRKÁNYI, M.: Fundamental Questions of Theory of Construction of Non-Tectonic Building (in Hungarian). Publishing House of the Hungarian Academy of Sciences. Budapest 1984.
13. PÁRKÁNYI, M.: Non-Tectonic Systems. An Illustrated Report of the Open Lightweight Silicate-Based Building Systems. *Per. Pol. Arch.* Vol. 29, Nos 3—4. pp. 93—159 Budapest 1985.
14. PÁRKÁNYI, M.: Non-Tectonic Systems. Building Methods of Technological Relevance for Hot Arid Tropical Areas. *Per. Pol. Arch.* Vol. 29, Nos 3—4 pp. 159—209 Budapest 1985.
15. PÁRKÁNYI, M.: Non-Tectonic Systems: Communal Buildings. The "Lift-cell" building method. *Per. Pol. Arch.* Vol. 30 Nos. 1—2. pp. 1—46 Budapest 1986.
16. PÁRKÁNYI, M.: Non-Tectonic Systems: Industrial Workshops. The "Tilt-lift" building method. *Per. Pol. Arch.* Vol. 30 Nos. 1—2. pp. 47—86 Budapest 1987.

Dr Mihály PÁRKÁNYI H-1521, Budapest