

Comprehensive Processing of Vanadium-Containing Black Shale Tailings

Viktor Shevko¹, Dosmurat Aitkulov², Alexandra Badikova^{1*}

¹ Department of Metallurgy, Higher School of Chemical Engineering and Biotechnology, Mukhtar Auezov South Kazakhstan University, Tauke Khan avenue 5, 160012 Shymkent, Kazakhstan

² National Center on Complex Processing of Mineral Raw Materials of the Republic of Kazakhstan, Zhandosov st. 67, 050036 Almaty, Kazakhstan

* Corresponding author, e-mail: sunstroke_91@mail.ru

Received: 23 February 2022, Accepted: 09 May 2022, Published online: 23 June 2022

Abstract

This article examines results of the thermodynamic modeling of interaction of the briquetted tailings obtained at hydrometallurgical leaching of the vanadium-containing quartzites (black shales) with carbon and iron, determination of Si, V, Fe, C equilibrium distribution and optimal conditions for the formation of various grades of ferrosilicon, as well as the electric melting to produce silicon alloys. The research techniques were the method of thermodynamic modeling using the HSC-6.0 software package (Outokumpu), the second-order rotatable designs (Box-Hunter plans) and electrofusion in an arc furnace. It was established that an increase in the amount of iron from 11 to 39% makes it possible to increase the extraction degree of silicon into an alloy up to 72–73% in the temperature of 1800–2000 °C, in the process the silicon concentration in the alloy decreases from 57–65.7 to 40.5–40.9%; FS45-grade ferrosilicon at the extraction degree of silicon in the alloy of 70–72.6% can be formed in the temperature of 1750–2000 °C in the presence of 29–39% Fe, FS50 ferrosilicon is formed at 25.5–35.0% Fe and 1870–2000 °C, and FS65 ferrosilicon – in the temperature of 1895–2000 °C in the presence of 11–12.7% Fe. The FS45-grade ferrosilicon was formed during electric smelting of a charge containing 57% of the briquettes, 21% of coke, 22% of steel chips, and the FS50-grade ferrosilicon – using a charge consisting of 61% of the briquettes, 22% of coke and 17% of steel chips; the silicon extraction degree into the alloys is 73–79%.

Keywords

vanadium-containing quartzite, leaching tailings, thermodynamic modeling, electric smelting, ferrosilicon

1 Introduction

The BalaSauyskandyk uranium-vanadium black shale deposit, located in the northwestern part of the Karatau ridge, is one of the five largest vanadium-containing deposits in the world (in 2014 its reserves amounted to 70 million tons) [1]. The vanadium-containing quartzite (black shales) is proposed to use as a flux in the production of high-carbon ferrochrome, and also as a charge component in the production of ferrosilicochrome to obtain a complex alloy containing chromium, vanadium and silicon [2]. It was proved that the vanadium-containing quartzites can be used as a flux at manufacturing yellow phosphorus to produce ferrophosphorus containing 4–6% vanadium [3]. In metallurgy, acid leaching of non-ferrous metals from various raw materials has become widespread. The effectiveness of this method

has been proven in the extraction of copper from oxide copper ores [4], zinc from sulfide ores [5], and vanadium raw materials [6–9]. So, on the basis of this, several methods for processing the quartzite to extract vanadium have been proposed, involving roasting, sulfuric acid leaching of the cinder, and hydrolysis of the resulting solution [10]; acid leaching followed by sorption of vanadium [11]; roasting, leaching with a soda solution, filtering the resulting solution and its subsequent electrochemical treatment [12]; two-stage leaching (sulfuric acid oxidation and autoclave leaching) followed by sorption of vanadium [13, 14]; direct extraction with preliminary sulfatization [15]. Combinations of pyrometallurgical and hydrometallurgical methods to produce pure vanadium are also known [16].

The National Center for Complex Processing of Mineral Raw Materials of the Republic of Kazakhstan has developed a technology for sulfuric acid autoclave leaching of vanadium-containing quartzites (the Big Karatau black shales) in the presence of elemental sulfur. The extraction degrees from the quartzites are: vanadium – 85%, molybdenum – 80%, uranium – 99%, REE – 75% [17, 18].

The methods described above do not provide the comprehensive processing of vanadium-containing quartzites (black shales). To comprehensively process this type of a raw material, we have proposed a technology for processing of the tailings formed at the leaching the BalaSauyskandyk vanadium-containing quartzites (black shales) and producing various grades of ferrosilicon from them. A similar technology was developed by us for processing of some siliceous ores and industrial wastes [19, 20].

This article contains the results of the thermodynamic modeling of interaction of the briquetted tailings obtained at hydrometallurgical processing of the BalaSauyskandyk vanadium-containing quartzites (VQLT) with carbon and iron, determination of Si, V, Fe, C equilibrium distribution and optimal conditions for the formation of various grades of ferrosilicon, as well as the electric melting of the VQLT briquettes to produce silicon alloys.

2 Research methodology, initial materials

The main words in the title start with capital letter, articles and conjunctions with lowercase letters. The research techniques included thermodynamic modeling (the full thermodynamic analysis) and electric smelting of the VQLT in an arc furnace.

The thermodynamic modeling was carried out by means of a multifunctional software package Outokumpu based on the $\Delta G^0 \rightarrow \min$ principle [21] using the Equilibrium Compositions subprogram of the HSC-6.0 complex. The equilibrium parameters of thermodynamic systems were determined by solving a mathematical task connected with determination of an extremum, taking into account all restrictions and using the Lagrangian functions and Newton's method of successive approximations [22]. The HSC-6.0 software package presents the initial information in the form of a quantitative (kg) distribution of substances in the system under study. Determination of the equilibrium distribution degree of any elements (α , %) in the resulting products was carried out in accordance with the algorithm developed in Mukhtar Auezov South Kazakhstan University [23].

The electric smelting of a charge containing the VQLT briquettes was implemented using an installation, the main element of which was a single-phase single-electrode electric arc furnace (Fig. 1).

A graphite crucible with a diameter of 90 mm and a height of 250 mm was installed on a graphite hearth in the furnace. A diameter of a graphite electrode was 70 mm. The furnace in its upper part has an opening lid with a hole with a diameter of 12 cm for inserting the electrode. The furnace was equipped with a screw-type device for supporting and moving the electrode. Energy was supplied from a TDZhF-1002 furnace transformer, which was equipped with a terristor regulator. The maximum power of the transformer is 56 kV A.

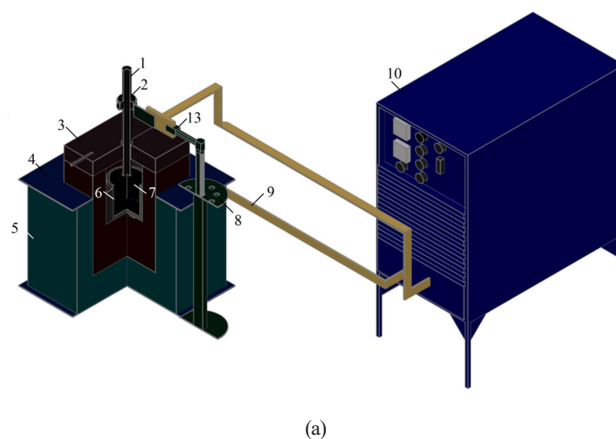

Fig. 1 A single-electrode electric arc furnace, (a) a sketch of the furnace, 1 – electrode; 2 – clamp; 3 – lid; 4 – lining; 5 – furnace casing; 6 – coke; 7 – crucible; 8 – mechanism for moving the electrode, 9 – bus; 10 – transformer, (b) a photo of the furnace

A short network was made in the form of aluminium buses (1.5×4.5 cm) and a flexible part (from the bus to the electrode). The aluminum busbar of the short network was attached to the graphite hearth by means of three copper studs. The current and voltage were controlled by means of ammeters and voltmeters installed on the transformer panel and the electric furnace panel (ammeter – TENGGEN 42L6GB/T7676-1998, voltmeter – CHNT 4226-China). The temperature under the furnace roof was measured with a TPP-0679 886 thermocouple and recorded with a METAKON RS-485 instrument.

The VQLT chemical composition was the following, mass %: SiO_2 – 72.5, Al_2O_3 – 1.25, CaO – 0.94, TiO_2 – 0.55, V_2O_5 – 0.4, MgO – 0.24, Fe_{gen} – 0.99, $\text{SO}_{2\text{gen}}$ – 0.95, Na – 0.093, K – 0.056, Cu – 0.008, Pb – 0.008, Zn – 0.002, W – 0.05, Ni – 0.017, Co < 0.01, Mn – 0.005, U – 0.001, As < 0.01, Cd < 0.01, Bi < 0.01, others. According to the conclusion of the central analytical laboratory "A-Mega Trading", the carbon content in the VQLT, determined by the gravimetric method, was 21.18%. The size of the briquettes was 0.5–1.5 m. The steel chips contained 97.6% of Fe, 1.9% of C, 0.5% of Si, Mn. The length of the chip strip was 0.5–1 cm; its width was 0.2–0.4 cm. The coke used contained C – 85.4%, SiO_2 – 4.8%, Fe_2O_3 – 2.5%, Al_2O_3 – 1.9%, CaO – 1.6%, MgO – 0.4%, S – 0.7%, H_2O – 1.2%, others – 1.5% (the coke fraction: 0.5–1 cm). The weight of the charge was 1.5–1.8 kg.

The first portion of the charge (500–600 g) was loaded into the heated furnace. After its melting for 8–10 min, the second portion was loaded, and then, after another 7–10 min,

the last portion of the charge was loaded. The total melting time was 40–50 min. During the melting period, the voltage was 20–25 V, and the current strength was 500–600 A. After the end of melting, the crucible was removed from the furnace with tongs and cooled for 2–3 hours. Then it was broken. Some fragments of the melting process are shown in Fig. 2. The resulting alloy was photographed, weighed, and analyzed using a JSM-6490LV scanning electron microscope (Japan) including INCA Energy energy-dispersive microanalysis and HKL-Basic structural analysis systems. The metals' extraction degrees into the alloy $\alpha_{\text{Me(al)}}$ were determined using the expression:

$$\alpha_{\text{Me(al)}} = \left[\frac{G_{\text{al}} \times C_{\text{Me(al)}}}{G_{\text{ch}} \times C_{\text{Me(ch)}}} \right] \times 100 \quad (1)$$

where G_{al} , G_{ch} – mass of the ferroalloy and the charge, kg, respectively; $C_{\text{Me(al)}}$, $C_{\text{Me(ch)}}$ – concentration of a metal in the alloy and in the charge, %, respectively.

3 Research results

Fig. 3 shows the effect of temperature and amount of iron on the equilibrium quantitative (kg) distribution of substances in the VQLT – nFe – C system when the carbon content is 32% of the VQLT mass (taking into account its content in the VQLT – 21.18%).

The received data show that the resulting silicon-containing products are Fe_3Si , Fe_5Si_3 , FeSi , FeSi_2 , $\text{FeSi}_{2.33}$, SiC , SiO_g , and Si. The main ones are FeSi , Si, SiO_g , SiC , Fe_3Si . Iron and silicon are reduced with the formation of CO. If 0.1%, is taken as the temperature of the beginning of the formation of the substance, then for Fe_3Si it is 1250–1280 °C,



Fig. 2 Fragments of electric smelting the VQLT-containing charge, (a) beginning of the melting, (b) end of the melting, (c) crucible during its cooling

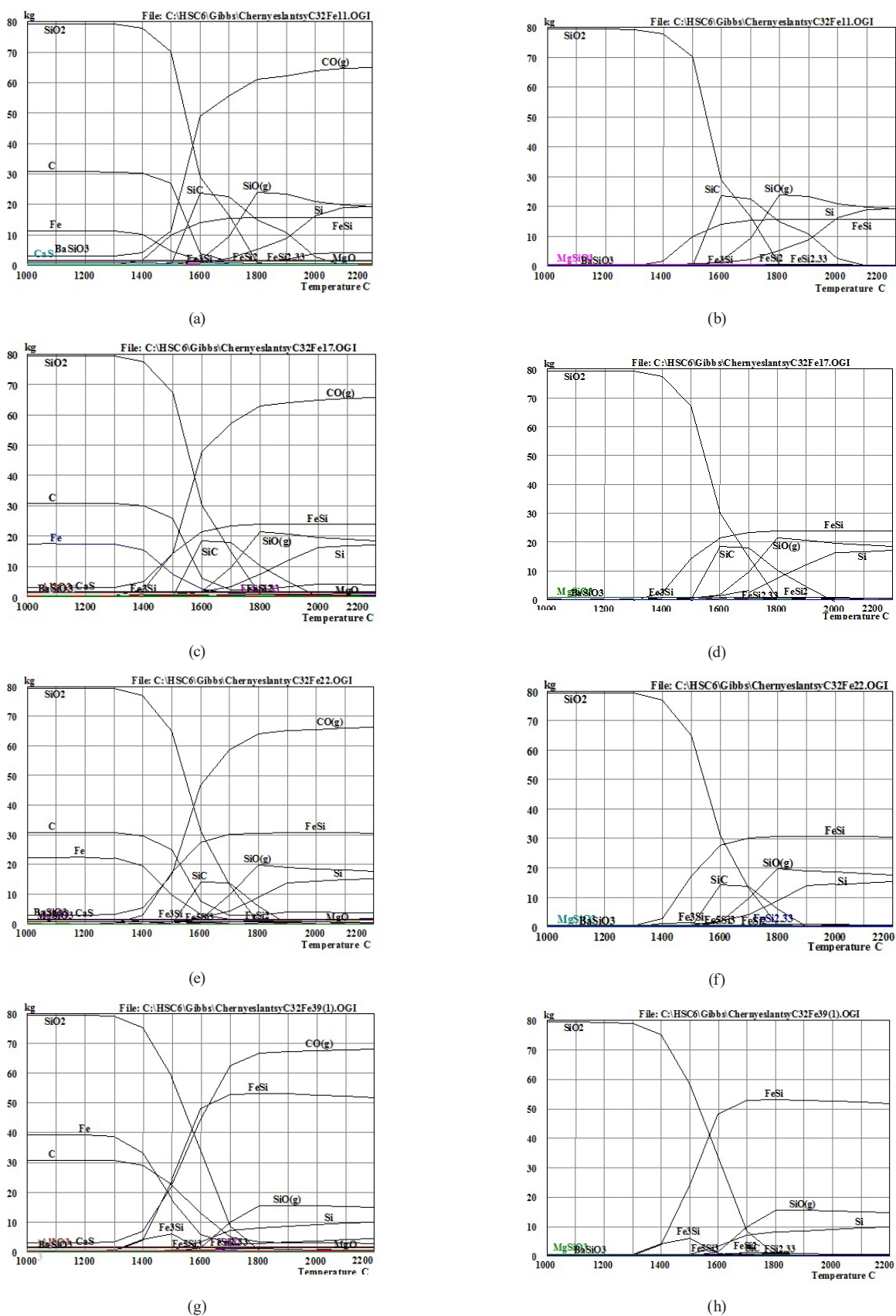

Fig. 3 The temperature and iron amount effect on the equilibrium quantitative distribution of substances in the VQLT-nFe-C system at a pressure of 1 bar, (a) general distribution, 11% Fe, (b) silicon-containing substances, 11% Fe, (c) general distribution, 17% Fe, (d) silicon-containing substances, 17% Fe, (e) general distribution, 22% Fe, (f) silicon-containing substances, 22% Fe, (g) general distribution, 39% Fe, (h) silicon-containing substances, 39% Fe

FeSi 1260–1290 °C, FeSi₂-1515–1530 °C, Si-1360–1380 °C, SiC-1600–1610 °C, SiO_g-1470–1500 °C. The maximum degree of silicon extraction in Fe₃Si is observed at 1500–1600 °C, FeSi-1800–1900 °C, FeSi₂-1700–1800 °C, SiC-1600–1700 °C, SiO_g-1470–1500 °C and Si-1800–1900 °C.

The effect of temperature and iron amount on the silicon equilibrium distribution degree (α , %) is represented in Fig. 4. As follows from Fig. 4, the complete reduction of SiO₂ occurs at 1800 °C. The formation of SiC is characterized by a maximum at 1600–1700 °C. Moreover, with an increase in the amount of iron from 11 to 39%, the extraction degree of silicon into SiC decreases from 44.42% to 1.22%. This is explained by the fact that iron is able to destroy SiC [24, 25]:



The extraction degree of silicon into the undesirable gaseous oxide SiO_g also decreases with increasing the iron content in the charge. So, at 1800 °C and 11% of iron $\alpha_{\text{Si}(\text{SiO}_g)} = 40.7\%$, and at 39%, $\alpha_{\text{Si}(\text{SiO}_g)}$ decreases to 26.39%. The observed phenomenon can be explained by the following reaction:

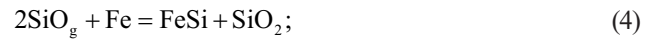

ΔG^0 of this reaction at 1800 °C is 88.95 kJ (Table 1).

An increase in the iron amount promotes the formation of FeSi. So, if the extraction degree of silicon into FeSi at 1900 °C and 11% of Fe was 13.99%, then at 39% of Fe it increases to 47.42%.

In addition, an increase in the amount of iron has a positive effect on the total extraction of silicon into the alloy in the form of Si, iron silicides, and silicon carbide (Table 2).

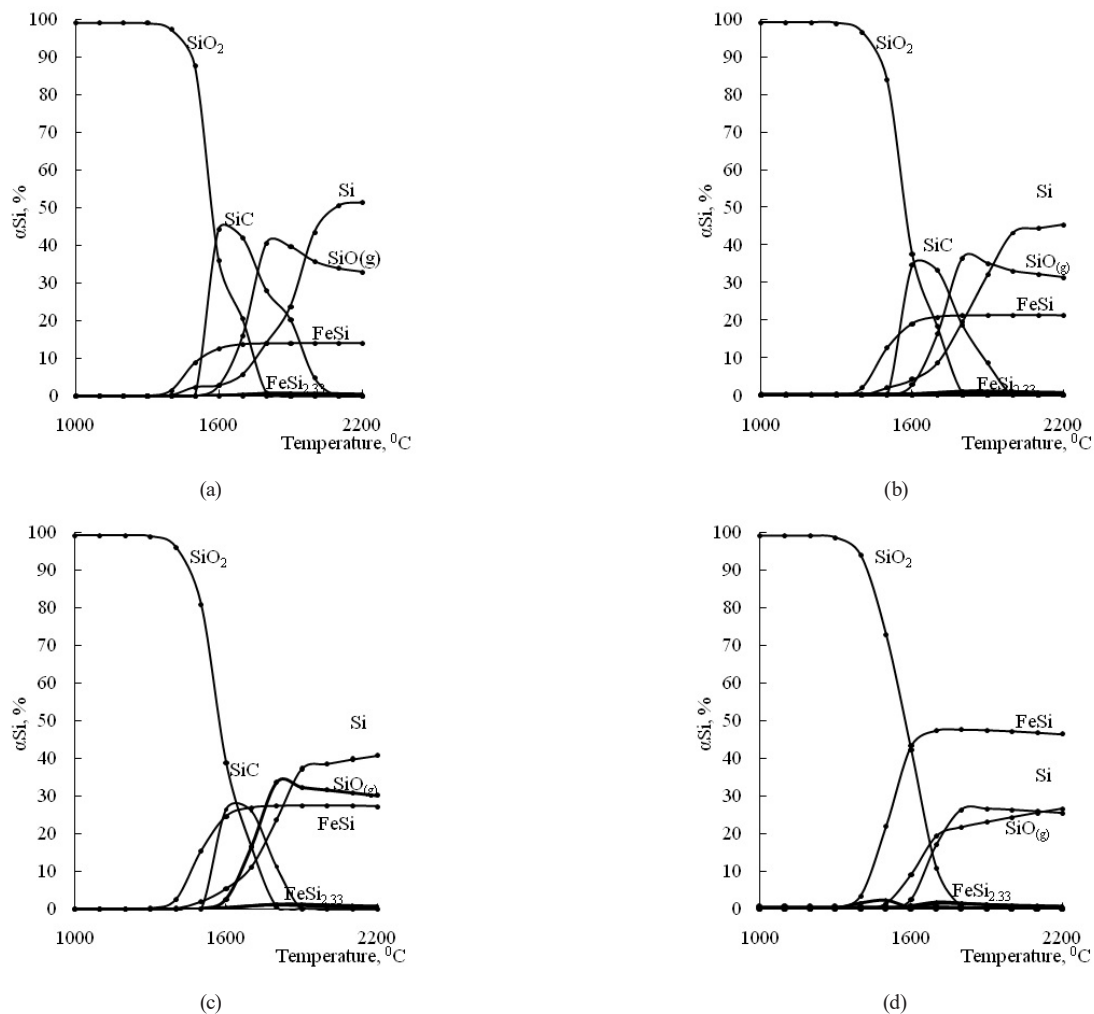

Fig. 4 The temperature and iron amount effect on the equilibrium silicon distribution degree in the VQLT-nFe-C system at a pressure of 1 bar, (a) 11% Fe, (b) 17% Fe, (c) 22% Fe, (d) 39% Fe

Table 1 ΔG^0 (kJ), ΔH^0 (kJ) and $\lg K$ for the $\text{SiO}_g\text{-Fe}$ interaction reaction*

Parameter	Temperature, °C							
	1300	1400	1500	1600	1700	1800	1900	2000
ΔH^0	-765.46	-762.75	-688.12	-698.00	-694.24	-680.04	-675.15	-670.28
ΔG^0	-238.99	-205.65	-176.24	-147.01	-117.69	-88.95	-60.56	-32.38
$\lg K$	7.937	6.421	5.193	4.100	3.116	2.242	1.456	0.744

* The calculation was performed using the Reaction Equations subprogram of the HSC-6.0 software package [21]

Table 2 Influence of temperature and iron amount on the extraction degree of silicon in the alloy, %

Iron amount, %	Temperature, °C				
	1800	1850	1900	1950	2000
11	57.71	58.24	59.71	60.75	63.83
17	61.99	94.63	64.26	65.39	66.53
22	65.07	66.61	57.21	66.87	68.06
39	72.43	73.60	72.93	73.30	73.42

In a temperature range of 1000–2200 °C, vanadium was completely reduced and passed into the alloy. At a temperature above 1300 °C, phosphorus completely transforms into gaseous P_2 (Fig. 5). As follows from Fig. 5, to 1300 °C, an increase in the amount of iron causes a decrease in the conversion degree of phosphorus to $\text{P}_{2(g)}$.

The effect of temperature and iron on the silicon and vanadium concentrations in the alloy is represented in Fig. 6. It can be seen that the silicon and vanadium concentrations in the alloy naturally decrease with an increase in the amount of iron. In the temperature interval of 1800–2000 °C, the silicon concentration in the alloy can reach 57.2–67.8% at 11% of iron and 40.6–40.9% at 39% of iron. The vanadium concentration at 2000 °C is 0.61% for 11% of Fe and 0.33% for 39% of Fe.

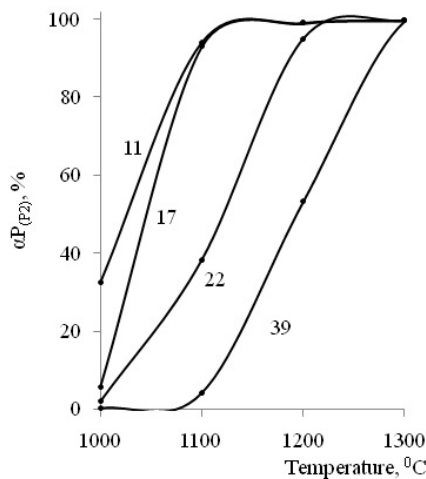
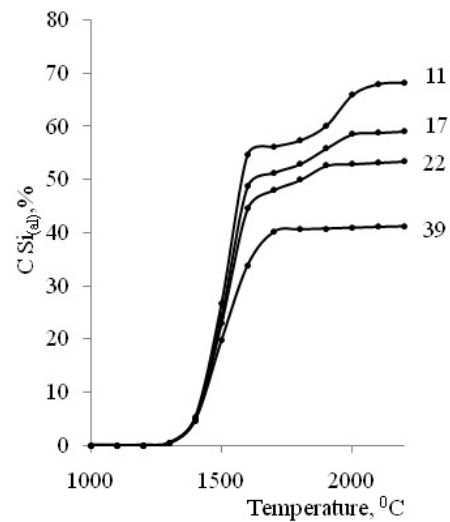
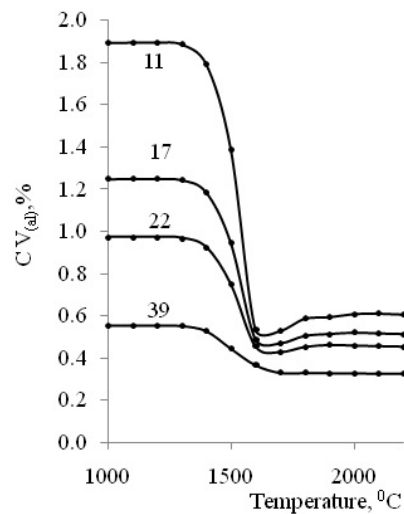

Fig. 5 Effect of temperature and iron on the transition degree of phosphorus to gaseous P_2 , the numbers near the lines – the amount of iron, %

To develop a mathematical thermodynamic model of the process under study and determine the temperature and iron effect on the silicon extraction degree in the alloy and the silicon content in it, further studies were implemented by means of the second-order rotatable planning. Tables 3 and 4 contain matrices of the studies and their results.



(a)



(b)

Fig. 6 Effect of temperature and iron on the silicon (a) and vanadium (b) content in the alloy, the numbers near the lines – the amount of iron, %

Table 3 The planning matrix and results of studying the effect of temperature (T , °C) and iron amount (Fe, % of the VQLT mass) on the total extraction degree of silicon in the alloy

№	Variables				$\alpha_{Si(al)}$, %
	Code kind		Natural kind		
	X1	X2	T, °C	Fe, %	
1	-1	-1	1829	15.1	62.4
2	+1	-1	1971	15.1	65.0
3	-1	+1	1829	34.9	70.3
4	+1	+1	1971	34.9	72.0
5	+1.414	0	2000	25.0	70.1
6	-1.414	0	1800	25.0	67.2
7	0	+1.414	1900	39.0	72.8
8	0	-1.414	1900	11.0	59.9
9	0	0	1900	25.0	65.3
10	0	0	1900	25.0	64.0
11	0	0	1900	25.0	64.8
12	0	0	1900	25.0	63.9
13	0	0	1900	25.0	63.2

Table 4 The planning matrix and results of studying the effect of temperature (T , °C) and iron amount (Fe, % of the VQLT mass) on the silicon concentration in the alloy

№	Variables				$C_{Si(al)}$, %
	Code kind		Natural kind		
	X1	X2	T, °C	Fe, %	
1	-1	-1	1658.2	15.1	56.6
2	+1	-1	1941.8	15.1	60.3
3	-1	+1	1658.2	34.9	39.7
4	+1	+1	1941.8	34.9	45.1
5	+1.414	0	2000.0	25.0	52.6
6	-1.414	0	1600.0	25.0	43.1
7	0	+1.414	1800.0	39.0	41.0
8	0	-1.414	1800.0	11.0	60.3
9	0	0	1800.0	25.0	48.0
10	0	0	1800.0	25.0	48.6
11	0	0	1800.0	25.0	48.3
12	0	0	1800.0	25.0	49.0
13	0	0	1800.0	25.0	47.3

Based on the results shown in Tables 3 and 4, the following adequate regression equations were obtained:

$$\alpha_{Si(al)} = -237.61 + 0.278 \times T + 1.81 \times Fe - 6.72 \times 10^{-6} \times T^2 - 1.52 \times 10^{-2} \times Fe^2 - 3.2 \times 10^{-4} \times T \times Fe; \quad (5)$$

$$C_{Si(al)} = 70.21 - 5.25 \times 10^{-3} \times T - 2.06 \times Fe + 4.873 \times 10^{-6} \times T^2 + 1.52 \times 10^{-2} \times Fe^2 + 3.03 \times 10^{-4} \times Fe \times T. \quad (6)$$

Then, according to [26, 27], volumetric and planar images of the dependences $\alpha_{Si(al)} = f(T, Fe)$, $C_{Si(al)} = f(T, Fe)$ were constructed (Figs. 7 and 8). As follows from Fig. 7, $\alpha_{Si(al)} \geq 70\%$ can be achieved in the temperature interval of 1800–1900 °C and 25.3–39% of iron (shaded area of Fig. 7 (b)). In the system under study, it is possible to obtain three grades of ferrosilicon (Fig. 8). The FS45 and FS50 grades of ferrosilicon can be form in the temperature area of 1600–2000 °C. However, FS45 ferrosilicon is formed in the presence of 32.2–21.8% of iron, and FS65 – in the presence of 21.8–15.6% of iron. FS65-grade ferrosilicon is formed at a higher temperature and a small amount of iron ($T = 1893\text{--}2000$ °C, $Fe = 11\text{--}12.8\%$).

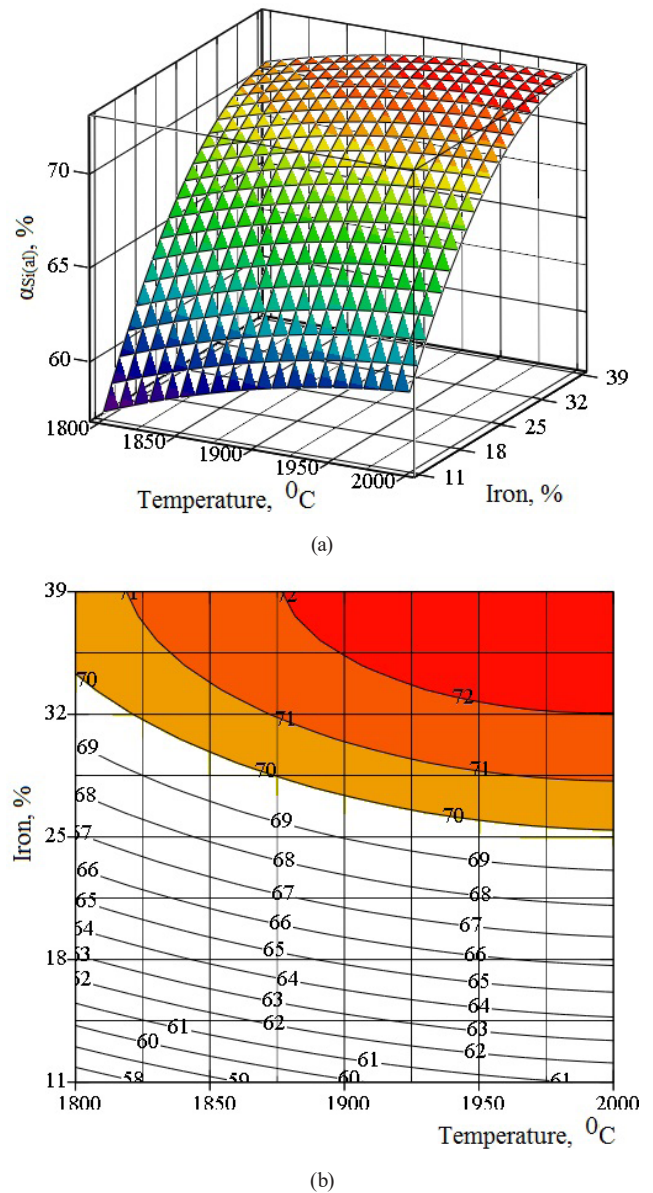
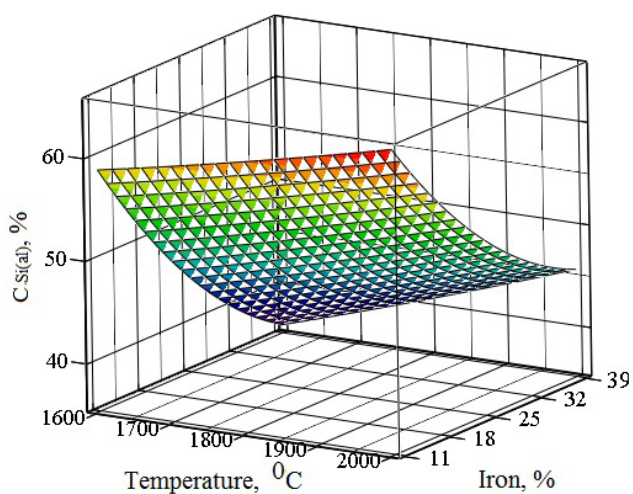
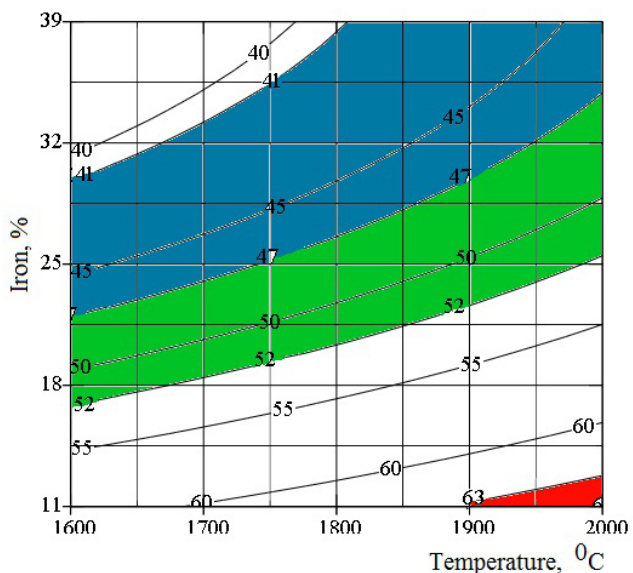

Fig. 7 Effect of temperature and iron on the extraction degree of silicon in the alloy, (a) volumetric image, (b) horizontal section



(a)



(b)

Fig. 8 Effect of temperature and iron on the silicon concentration in the alloy, (a) volumetric image, (b) horizontal section, blue - FS45, green - FS50, red - FS65

Figs. 7 and 8 show that changing in the amount of iron at constant temperature leads to the opposite behavior of the parameters $\alpha_{Si(al)}$ and $C_{Si(al)}$. If $\alpha_{Si(al)}$ increases, then $C_{Si(al)}$ decreases. Conversely, with decrease in $\alpha_{Si(al)}$, $C_{Si(al)}$ grows.

To select the optimal values of temperature and iron amount, which provide a certain grade of ferrosilicon, we combined two images – $\alpha_{Si(al)} = f(T, Fe)$ and $C_{Si(al)} = f(T, Fe)$ – in one plane (Fig. 9).

In Fig. 9, the area *albce* is the FS45 formation area, the *hecm* region is the FS50 formation area, and the *xyt* region is the FS65 one. If we accept $\alpha_{Si(al)} \geq 70\%$, then it is possible to determine the conditions for formation of FS45 and FS50. So FS45 is formed in the *flbcd* area, FS50 – in the *mdc* area.

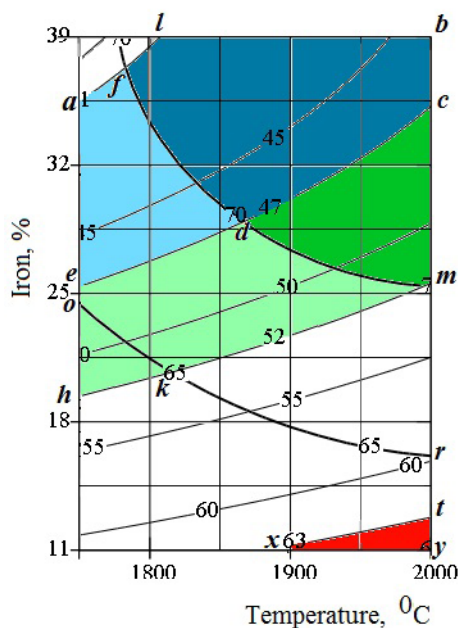

Fig. 9 Combined information on the effect of temperature and iron on the technological parameters of the VQLT melting

Under the condition $\alpha_{Si(al)} \geq 65\%$, ferrosilicon FS45 can be formed in the *albce* area, and ferrosilicon FS50 in the *oedcmk* area.

The formation of FS65 occurs in a narrow high-temperature *xyt* area. In this case, the extraction degree of silicon into the alloy is only 59.8–62.5%. The technological parameters at the boundary points during the formation of different grades of ferrosilicon are shown in Table 5.

Judging by the data of Table 5, if $\alpha_{Si(al)} \geq 70\%$, then the temperature and iron amount necessary for formation of FS45 ferrosilicon should be 1785–2000 °C and 29–39% of

Table 5 Values of technological parameters at the boundary points of Fig. 9

Points in Fig. 9	Technological parameters			
	Temperature, °C	Fe, %	$\alpha_{Si(al)}$, %	$C_{Si(al)}$, %
<i>a</i>	1750	35.3	68.8	41.0
<i>b</i>	2000	39.0	72.6	45.8
<i>c</i>	2000	35.0	72.4	47.0
<i>d</i>	1870	29.0	70.0	47.0
<i>e</i>	1750	25.3	65.5	47.0
<i>h</i>	1750	19.0	61.8	52.0
<i>k</i>	1817	20.7	65.0	52.0
<i>l</i>	1810	39.0	70.8	41.0
<i>m</i>	2000	25.5	70.0	52.0
<i>o</i>	1750	24.7	65.0	47.5
<i>r</i>	2000	16.2	65.0	59.7
<i>f</i>	1785	37.0	70.0	41.0
<i>t</i>	2000	12.7	62.5	63.0
<i>x</i>	1895	11.0	59.8	63.0
<i>y</i>	2000	11.0	61.1	65.1

the VQLT mass, respectively (in this case $\alpha_{Si(al)}$ is 70.0–72.6%, and $C_{Si(al)}$ is 41.0–47.0%). The formation of FS50 ferrosilicon, at the condition that $\alpha_{Si(al)} \geq 70\%$, occurs at 1870–2000 °C and 25.5–35.0% of iron (in this case, $\alpha_{Si(al)}$ is 70.0–72.4%, and $C_{Si(al)}$ is 47.0–52.0%). If we accept $\alpha_{Si(al)} \geq 65\%$, then FS45 is formed at 1750–2000 °C and 25.3–39.0% of Fe, and FS50 is formed in the same temperature interval – 1750–2000 °C and the iron amount of 20.7–35.0%. The formation of FS65 grade (for $\alpha_{Si(al)} = 59.8–62.5\%$) occurs in the temperature area of 1895–2000 °C and 11.0–12.7% of Fe. Despite the fact that the equilibrium carbon content in this alloy (during its formation) is 1.9–7.7%, and this parameter does not meet the requirements of State Standard 1415-93 [28], the alloy can be considered as a standard based on the properties of the SiC contained in it. It is known that alloys containing more than 23.18% of silicon are in equilibrium with silicon carbide [29]. The solubility of SiC in a ferroalloy increases with increasing temperature. When pouring ferrosilicon into a ladle, the temperature of the alloy decreases and the SiC solubility also decreases. This leads to the precipitation of solid SiC particles during the cooling of the alloy in the ladle and a significant decrease in the carbon content in the alloy. For this reason, industrial ferrosilicon actually contains a small amount of carbon (no more than 1%) [24, 30].

Experimental electro smelting of VQLT was carried out using two charge compositions:

1. 67% of VQLT, 11% of coke, 22% of steel shavings;
2. 71% of VQLT, 12% of coke, 17% of steel shavings.

Photographs of the ferroalloys are shown in Fig. 10, and their SEM analyses in Fig. 11 and in Tables 6 and 7.

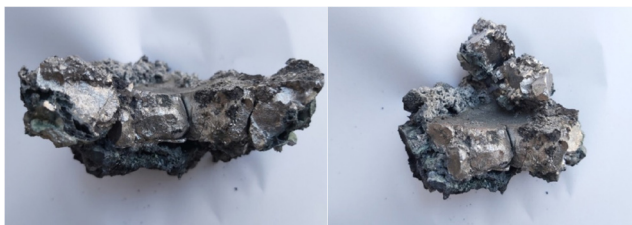

(a)



(b)

Fig. 10 Photographs of the ferroalloys produced, (a) 2nd smelting, (b) 3rd melting

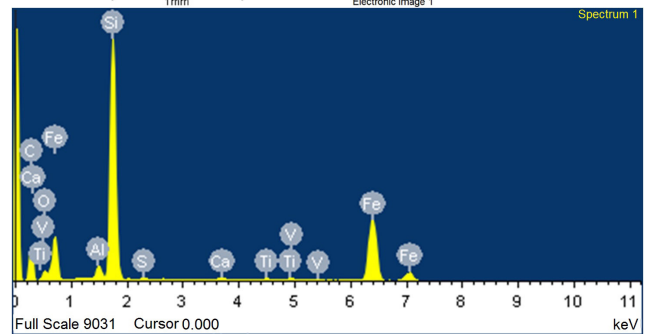
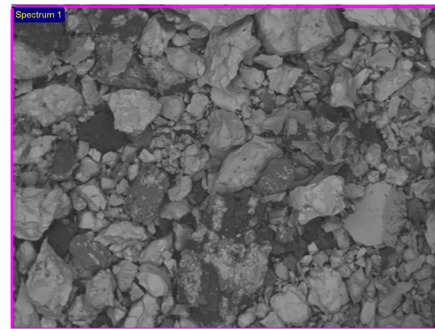

(a)

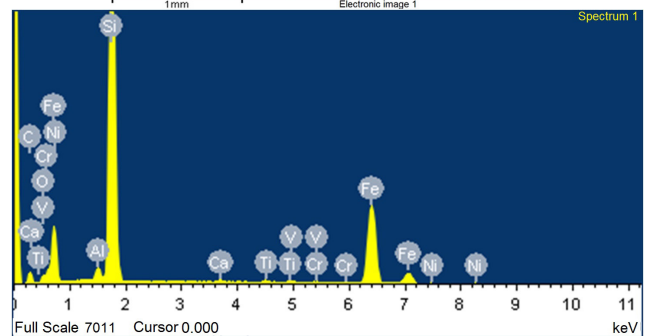

(b)

Fig. 11 SEM analyses of the ferroalloys' samples, (a) 2nd smelting, (b) 4th smelting (Original SEM images are in Russian)

Table 6 SEM analyses of the ferroalloys' samples according to Fig. 11 (a) 2nd smelting (amounts in %)

C	Al	Si	S	Ca	O	Ti	V	Fe
37.47	2.59	44.11	0.26	0.58	5.86	0.62	0.42	51.09

Table 7 SEM analyses of the ferroalloys' samples according to Fig. 11 (b) 4th smelting (amounts in %)

C	Al	Si	Ca	Ti	O	V	Cr	Fe	Ni
16.51	1.69	54.83	0.34	0.47	3.43	0.4	0.31	41.53	0.34

It can be seen from Fig. 11 and from Tables 6 and 7 that, in addition to metals, the alloys contain carbon and oxygen; their presence is owing to the fact that under the conditions of electric smelting the charge in a crucible, a fairly complete separation of the alloy from slag and unreacted charge, including coke, did not occur. (In Fig. 11 and in Tables 6 and 7, coke particles appear as black areas). To establish the true metals' content, it is necessary to take into account the slagging of a part of silicon with oxygen and the presence of the charge coke in the alloy. The silicon concentration, for example, in 100 g of the alloy in this case is calculated according to the expression:

$$C_{\text{Si}} = \frac{C_{\text{Si}(p)} - C_{\text{O}(p)} \times \frac{A_{\text{Si}}}{M_{\text{O}_2}}}{100 - C_{\text{C}(p)} - C_{\text{O}(p)} - C_{\text{O}(p)} \times \frac{A_{\text{Si}}}{M_{\text{O}_2}}} \quad (7)$$

where:

$C_{\text{Si}(p)}$, $C_{\text{O}(p)}$, $C_{\text{C}(p)}$ – concentrations of silicon, oxygen and carbon in the alloy according to the SEM analysis, shares of 1;

$C_{\text{O}(p)} \times \frac{A_{\text{Si}}}{M_{\text{O}_2}}$ – the mass of silicon bound to oxygen in the alloy; A_{Si} and M_{O_2} – the atomic silicon mass and the molecular oxygen mass.

In our case, the silicon content in the 1st ferroalloy will be:

$$C_{\text{Si}} = \frac{25.00 - 5.86 \times 28/32}{100 - 37.47 - 5.86 - 5.86 \times 28/32} \times 100 = 38.56\%, \quad (8)$$

for the 2nd ferroalloy:

$$C_{\text{Si}} = \frac{43.90 - 3.43 \times 28/32}{100 - 16.51 - 3.43 - 3.43 \times 28/32} \times 100 = 53.07\%. \quad (9)$$

In terms of silicon content, the first ferroalloy practically corresponds to FS45 grade ferrosilicon [28], in which the silicon concentration is 39–47%, and the second one – to FS50 grade ferrosilicon (Si = 47–52%). The second alloy, in addition to 53.07% of Si, also contains 43.15% of Fe, 1.75% of Al, 0.52% of V, 0.49% of Ti, 0.35% of Ni, 0.35% of Ca, 0.32% of Cr. The extraction degree of silicon into the alloy during the first electric melting was 73.8%, and during the second one was 79.8%.

From a comparison of the results of thermodynamic modeling (TDM) and experimental melting (Fig. 9, Table 5), it can be seen that during electric melting, the degree of silicon extraction into the alloy is greater by 79.8 – 72.4 = 7.4%. This is due to the fact that during electric melting, the losses of silicon with gaseous SiO, are reduced, due to the presence of a grate in the furnace.

Therefore, when switching from TDM to the practical implementation of the technology for obtaining ferroalloys from other silica-containing raw materials, a higher degree of silicon extraction into the alloy should be expected.

The smelting of ferroalloys from vanadium quartzite leaching tails containing 19–22% carbon can significantly (2.5–3 times) reduce coke consumption and reduce the cost of the product by 4–6%. Vanadium-doped ferroalloy increases its cost. Preliminary calculations show that the payback period of the technology is 3–3.5 years.

4 Conclusion

The results of studies on the interaction of the briquetted tailings obtained at the hydrometallurgical processing the BalaSauyskandyk deposit vanadium-containing quartzites (black shales) with carbon in the presence of iron allow us to draw the following conclusions:

- In equilibrium conditions:
 - the temperature of the beginning of SiO₂ recovery from briquettes occurs at a temperature >1250 °C with the formation of FeSi₂, FeSi, Fe₃Si₃, Fe₃Si, FeSi_{2.33}, SiO_g, SiC, Si;
 - an increase in the amount of iron from 11 to 39% promotes to increase the silicon extraction degree in the alloy up to 72–73% in the temperature range 1800–2000 °C, while the silicon concentration in the alloy decreases from 57–65.7 to 40.5–40.9%;
 - FS45 ferrosilicon at the silicon extraction degree in the alloy of 70–72.6% can be formed in the temperature interval of 1750–2000 °C in the presence of 29–39% of Fe; FS50 grade – at 25.5–35.0% of Fe at 1870–2000 °C, and FS65 grade – in the temperature range of 1895–2000 °C in the presence of 11–12.7% of Fe.
- When electric smelting the VQLT briquettes:
 - FS45 ferrosilicon is formed from a charge containing 57% of the briquettes, 21% of coke, 22% of steel shavings, and FS50 ferrosilicon is formed in a case of using a charge consisting of 61% of the briquettes, 22% of coke and 17% of steel shavings; the extraction degree of silicon into alloys is 73–79%.
- During the transition from thermodynamic modeling (TDM) to the practical implementation of obtaining ferroalloys from silica-containing raw materials, an increase in the degree of silicon extraction into the alloy should be expected.

References

- [1] N. N. "Palitra vanadiyevykh soyedineniy" (The palette of vanadium compounds), Mining and Metallurgical Industry, 4, p. 14, 2018. (in Russian)
- [2] Jumankulova, S. K., Zhuchkov, V. A., Alybaev, Zh. A., Sukharnikov, Yu. I. "Ispol'zovaniye vanadiyevykh kvartsitov pri proizvodstve khromistyykh ferrosplavov" (The use of vanadium quartzite in the production of chromium ferroalloys), In: Proceedings of International Scientific and Practical Conference "The Effective Technologies of Non-ferrous, Rare and Precious Metals Manufacturing", Institute of Metallurgy and Ore Beneficiation (IMOB) JSC, 2018, pp. 387–391. (in Russian) ISBN 978-601-323-132-7
<https://doi.org/10.31643/2018-7.39>
- [3] Dzhumankulova, S. K., Zhuchkov, V. I., Alybaev, Z. A., Bekenova, G. K. "Review of State and Prospects for Development of Vanadium Production in the Kazakhstan Republic", Metallurgist, 64(1–2), pp. 75–81, 2020.
<https://doi.org/10.1007/s11015-020-00968-z>
- [4] Zharmenov, A. A., Terlikbaeva, A. Zh., Bukturov, N. S., Shevko, V. M., Abdibekov, N. K., Aitkulov, D. K., Ananin, A. I., Kushakova, L. B., Shamganova, L. S. "Novyye tekhnologii dobychi i pererabotki trudnoobogatimogo polimetallicheskogo syr'ya" (New technologies for the extraction and processing of refractory polymetallic raw materials), National Center on Complex Processing of Mineral Raw Materials of the Republic of Kazakhstan, Almaty, Kazakhstan, 2019. (in Russian)
- [5] Onukwuli, O. D., Nnanwube, I. A. "Optimization of Zinc Recovery from Sphalerite Using Response Surface Methodology and Particle Swarm Optimization", Periodica Polytechnica Chemical Engineering, 66(1), pp. 20–29, 2022.
<https://doi.org/10.3311/PPCh.17897>
- [6] Wahoud, A., Alouche, A., Abdalbake, M. "Sulfuric acid baking and leaching of spent sulfuric acid catalyst", Periodica Polytechnica Chemical Engineering, 55(1), pp. 31–34, 2011.
<https://doi.org/10.3311/pp.ch.2011-1.06>
- [7] Li, M., Wei, C., Fan, G., Wu, H., Li, C., Li, X. "Acid leaching of black shale for the extraction of vanadium", International Journal of Mineral Processing, 95(1–4), pp. 62–67, 2010.
<https://doi.org/10.1016/j.minpro.2010.04.002>
- [8] Luo, Y., Che, X., Wang, H., Zheng, Q., Wang, L. "Selective extraction of vanadium from vanadium-titanium magnetite concentrates by non-salt roasting of pellets-H₂SO₄ leaching process", Physicochemical Problems of Mineral Processing, 57(4), pp. 36–47, 2021.
<https://doi.org/10.37190/ppmp/138281>
- [9] Baigenzhenov, O. S., Yulussov, S. B., Khabiyev, A. T., Sydykanov, M. M., Akbarov, M. S. "Investigation of the leaching process of rare-earth metals from the black shale ores of greater karatau", Complex Use of Mineral Resources, 310(3), pp. 76–80, 2019.
<https://doi.org/10.31643/2019/6445.31>
- [10] Kozitsyn, A. A., Plekhanov, K. A., Mosyagin, S. A., Sheveleva, L. D., Lebed, A. B., Khodyko, I. I., Aktsionernoe Obshchestvo Otkrytogo Tipa 'Uralkhlektromed' "Method of processing vanadium-containing raw materials", Russia, RU2148669C1, 2000.
- [11] Kozlov, V. A., Batrakova, L. Kh., Kuznetsov, A. J., Bridzhen, N. D., Saktaganov, M. A., Tovarishchestvo s ogranichennoj otvetstvennost'ju nauchno proizvodstvennoe ob edinenie vanadij katalizator, Tovarishchestvo s ogranichennoj otvetstvennost'ju 'Firma 'Balasau' "Method of vanadium-bearing raw material processing", Russia, RU2374345C2, 2009.
- [12] Kozlov, V. A., Kamenskikh, A. A., Karpov, A. A., Vdovin, V. V. "Method of processing vanadium-containing converter slag", Russia, RU2266343C2, 2005.
- [13] Sarychev, G. A., Denisenko, A. P., Zatssepina, M. S., Denginova, S. J., Tatarinov, A. S., Smirnov, K. M., Peganov, V. A., Otkrytoe aktsionernoe obshchestvo 'Vedushchij nauchno-issledovatel'skij institut khimicheskoy tekhnologii' "Complex processing method of carbon-silicic black-shale ores", Russia, RU2477327C1, 2013.
- [14] Kozlov, V. A., Batrakova, L. Kh., Kuznetsov, A. J., Bridzhen, N. D., Saktaganov, M. A., Tovarishchestvo s ogranichennoj otvetstvennost'ju 'Nauchno-proizvodstvennoe obedinenie "Vanadij-katalizator', Tovarishchestvo s ogranichennoj otvetstvennost'ju 'Firma 'Balasau' "Method of vanadium-bearing raw material processing", Russia, RU2374344C2, 2009.
- [15] Chekmarev, A. M., Buchikhin, E. P., Parygin, I. A., Smirnov, K. M. "Patterns of Extractive Leaching of Uranium and Vanadium from an Ore", Theoretical Foundations of Chemical Engineering, 45(5), pp. 776–778, 2011.
<https://doi.org/10.1134/S0040579511050046>
- [16] Petranikova, M., Tkaczyk, A. H., Bartl, A., Amato, A., Lapkovskis, V., Tunsu, C. "Vanadium sustainability in the context of innovative recycling and sourcing development", Waste Management, 113, pp. 521–544, 2020.
<https://doi.org/10.1016/j.wasman.2020.04.007>
- [17] Komekova, N. A., Kozlov, V. A., Shayakhmetova, R. A. "Acid Leaching Of Vanadium From Black Shales Of Big Karatau", Research Journal of Pharmaceutical, Biological and Chemical Sciences, 7(2), pp. 1973–1982, 2016.
- [18] Komekova, N. M., Kozlov, V. A., Smirnov, K. M., Shayakhmetova, R. A., Nesterov, K. N. "Autoclave Leaching of Vanadium from Black Shale", Metallurgist, 60(11–12), pp. 1186–1190, 2017.
<https://doi.org/10.1007/s11015-017-0427-7>
- [19] Shevko, V. M., Zharmenov, A. A., Aitkulov, D. K., Terlikbaeva, A. "Complex processing of oxidized copper and zinc oxide ores with simultaneous production of several products", Physicochemical Problems of Mineral Processing, 57(1), pp. 226–249, 2021.
<https://doi.org/10.37190/ppmp/131091>
- [20] Shevko, V. M., Karataeva, G. E., Badikova, A. D., Tuleev, M. A., Uteeva, R. A. "Comprehensive Processing of Basalt together with Magnetite Concentrate in Order to Obtain Ferrous Alloy and Calcium Carbide", Archives of Foundry Engineering, 20(4), pp. 41–54, 2020.
<https://doi.org/10.24425/afe.2020.133346>
- [21] Roine, A. "HSC Chemistry®", [software] Metso:Outotec, Pori, 2021. Available at: www.mogroup.com/hsc [Accessed: 11 October 2021]

- [22] Udalov, Yu. P. "Primeneniye programnykh kompleksov vychislitel'noy i geometricheskoy termodinamiki v proyektirovaniy tekhnologicheskikh protsessov neorganicheskikh veshchestv" (Application of software complexes of computational and geometric thermodynamics in the design of technological processes of inorganic substances), St. Petersburg State Institute of Technology, St. Petersburg, Russia, 2012. (in Russian)
- [23] Shevko, V. M., Serzhanov, G. M., Karataeva, G. E., Amanov, D. D. "Расчет равновесного распределения элементов применительно к программному комплексу HSC-5.1" (Calculation of equilibrium distribution of elements as applied to the software package HSC-5.1), Certificate for the object protected by copyright of Republic of Kazakhstan, 1501, 2019. (in Russian)
- [24] Ershov, V. A. "Ferrosplavy v khimicheskoy promyshlennosti" (Ferroalloys in the chemical industry), Leningrad Technological Institute, Leningrad, USSR, 1980. (in Russian)
- [25] Gasik, M. I., Lyakishev, N. P., Emlin, B. I. "Teoriya i tekhnologiya proizvodstva ferrosplavov" (Theory and Technology of Ferroalloys Production), Metallurgy, 1988. (in Russian) ISBN 5-229-00418-5
- [26] Akhnazarova, S. L., Kafarov, V. V. "Metody optimizatsii eksperimenta v khimicheskoi tekhnologii" (Methods of Experiment Optimization in Chemical Technology), Vysshaya Shkola, Moscow, Russia, 1985. (in Russian)
- [27] Ochkov, V. F. "Mathcad 14 dlya studentov, inzhenerov i konstruktorov" (Mathcad 14 for students, engineers and designers), BHV-Petersburg, 2009. (in Russian) ISBN 978-5-9775-0403-4
- [28] Gosstandart of Russia "GOST 1415-93 Ferrosilitsiy: Tekhnicheskiye trebovaniya i usloviya postavki" (State standard 1415-93 Ferrosilicium. Specification and conditions of delivery), Standartinform, Moscow, Russia, 2011. (in Russian)
- [29] Gasik, M. I., Lyakishev, N. P. "Teoriya i tekhnologiya elektrometallurgii ferrosplavov" (Theory and technology of electrometallurgy of ferroalloys), SP Internet Engineering, 1999. (in Russian) ISBN 5-89594-022-6
- [30] Emlin, B. I., Gasik, M.I. "Spravochnik po elektrotermicheskim protsessam" (Handbook of Electrothermal Processes), Metallurgy, Moscow, Russia, 1978. (in Russian)