

Dandelion (*Taraxacum officinale*) Root Extract as a Green Corrosion Inhibitor of Steel in 3% NaCl

Marija Mitrović^{1*}, Suzana Apostolov², Regina Fuchs-Godec³, Bajro Salkunić¹, Gyöngyi Vastag², Milorad Tomić^{1,4}

¹ Faculty of Technology Zvornik, University of East Sarajevo, Karakaj 34A, 75400 Zvornik, Republic of Srpska, Bosnia and Herzegovina

² Department of Chemistry, Biochemistry and Environmental Protection, Faculty of Sciences, University of Novi Sad, Trg Dositeja Obradovića 3, 21000 Novi Sad, Serbia

³ Faculty of Chemistry and Chemical Engineering, University of Maribor, Smetanova 17, 2000 Maribor, Slovenia

⁴ Engineering Academy of Serbia, Kneza Miloša 9/1, 11000 Belgrade, Serbia

* Corresponding author, e-mail: marija.ridjosic@tfzv.ues.rs.ba

Received: 25 April 2024, Accepted: 06 September 2024, Published online: 26 September 2024

Abstract

This study investigates the potential of dandelion (*Taraxacum officinale*) root ethanol extract as a green corrosion inhibitor for two types of steel (TH-550 and TS-275) in a chloride-rich environment. Steel samples were chemically prepared and immersed in a 3% NaCl solution, both without and with the extract at concentrations of 0.5, 1.0, and 1.5 g/L. Morphology and composition of steel samples after 24 h in blank and inhibited solutions, examined by SEM and EDX, revealed the inhibitive effect of dandelion extract, since corrosion products were not visible on the steel surfaces after 24 h in the inhibited solution, unlike the blank steel surfaces. Based on the weight loss, dandelion extract inhibited corrosion processes of S2 in a chloride-rich environment at all examined concentrations; on the other hand, it acted as a corrosion inhibitor of S1 in 3% NaCl only at the concentrations of 1.0 and 1.5 g/L. According to corrosion current, corrosion potential and polarization resistance determined by potentiodynamic tests, dandelion root extract is a mixed corrosion inhibitor with a dominant anodic reaction, which decreases corrosion rate by adsorbing onto anodic sites and prevents steel dissolution. According to ATR-FTIR analysis, hydroxyl groups within the inulin molecule could act as the dominant metal-complexing groups. Therefore, the adsorption properties of dandelion root extract are most probably related to this specific site. Based on electrochemical impedance spectroscopy, the enhancement of corrosion resistance in the steel samples was evident in all the inhibited solutions examined compared to a pure 3% NaCl solution.

Keywords

steel failure prevention, green inhibitors, corrosion, green industry, electrochemical methods

1 Introduction

Steel is used in various industries due to its superior mechanical properties. However, it exhibits low resistance to corrosion, particularly in chloride-rich environments. The presence of chloride ions in the corrosive medium significantly accelerates the degradation of steel through multiple synergistic mechanisms. Beyond enhancing electrolyte conductivity, chloride ions promote corrosion through hygroscopic effects – they absorb moisture from the atmosphere, creating a more aggressive electrolyte layer on the steel surface. Additionally, unlike many metal chlorides, iron chloride (FeCl₂), which is a primary corrosion product of steel, exhibits high solubility in aqueous

environments. This solubility prevents the formation of a stable, protective oxide layer, leaving the underlying steel susceptible to further degradation. The corrosion product, FeCl₂, readily undergoes hydrolysis, yielding hydrochloric acid as a byproduct. This localized acidification reduces the pH at the steel surface, accelerating the corrosion rate. Moreover, the reaction proceeds autocatalytically, further exacerbating the degradation process. Corrosion inhibitors, particularly organic compounds, are often used to enhance corrosion resistance and durability of steel. These molecules adsorb onto the metal surface, forming a protective barrier that impedes corrosive agents from interacting

with the underlying steel. However, conventional organic inhibitors often have limitations, including toxicity concerns, limited solubility, and reduced efficiency under harsh operating conditions. Consequently, there is a growing interest in exploring sustainable corrosion inhibitors that would be both environmentally acceptable and highly effective. Natural plant extracts are very popular among environmentally friendly corrosion inhibitors [1–14]. Plant extracts, being rich in phytochemicals, can be adsorbed to steel surfaces by physisorption (this involves weak van der Waals forces attracting the plant extract molecules to the metal surface, forming a protective layer), chemisorption (which involves stronger chemical bonds forming between the plant extract molecules and the metal surface, leading to a more stable protective layer) and retrodonation (the donation of electrons from the plant extract molecules to the metal, reducing its reactivity and thus its susceptibility to corrosion) [15]. Plant extracts, derived from various plant parts, typically comprise a complex mixture of organic compounds rich in heteroatoms (S, N, O, P). These heteroatoms serve as active sites for adsorption onto metal surfaces, forming a protective barrier against corrosive agents [16]. These extracts offer several advantages. Since extracts are derived from renewable sources, they generally exhibit lower toxicity compared to their synthetic counterparts. Also, plants are readily available and often represent a more economically viable source compared to commercially produced chemicals. Numerous studies have demonstrated the efficiency of various plant extracts in inhibiting corrosion of steel and other metals in diverse corrosive media. Dandelion (*Taraxacum officinale*) extract has garnered particular attention in different fields due to its notable biological activities, including antimicrobial, antifungal, and antioxidant properties [3, 17–20]. Deyab and Guibal [3] examined dandelion extract for preventing the corrosion of cooling systems in desalination plants, and obtained an inhibition efficiency range from 45.8 to 94.3% depending on the extract concentration. Žbulj et al. [5] examined dandelion root extract as a green corrosion inhibitor of carbon steel in a simulated brine solution saturated with carbon dioxide, and obtained the inhibition efficiency of 57.2–76.8% in flow conditions. Bu et al. [21] examined crude saponin, flavonoid and alkaloid fractions from dandelion leaf extract as a corrosion inhibitor of steel in HCl, and the maximum calculated inhibition efficiency based on electrochemical impedance spectroscopy tests was 79%. Li et al. [22] examined dandelion extract as a corrosion inhibitor of magnesium alloys in 3.5% NaCl,

and found inhibition efficiency of 84.6% when the concentrations of extract reached up to 2.0 g/L. To the knowledge of the authors, there are only few research papers studying dandelion as a corrosion inhibitor, and there are no available reports about dandelion ethanol root extract as a corrosion inhibitor of steel in a NaCl solution. Thus, the aim of this study is to investigate the potential of dandelion root extract as a green corrosion inhibitor for two types of steel, TH-550 and TS-275, in a 3% NaCl corrosion medium. The research is focused on evaluating the inhibition efficiency of dandelion root extract and elucidating the mechanisms of its protective action through different experimental techniques.

2 Experimental part

Two types of steel were used in the experiments: TH-550 (S1) and TS-275 (S2), whose chemical compositions are given in Table 1.

Dandelion extract was obtained by Soxhlet extraction with 96% ethyl alcohol as a solvent. The extraction was performed using a Soxhlet apparatus with 10 g of solid plant material (dandelion root). The inhibitory effect of dandelion extract on steel corrosion was examined using weight loss measurements, potentiodynamic polarization and electrochemical impedance spectroscopy in 3% NaCl. All experiments were performed at room temperature. Prior to the experiments, the steel samples were prepared as followed: degreasing with detergent, chemical degreasing in a solution composed of NaOH = 35 g/L, Na₂CO₃ = 45 g/L and Na₃PO₄ · 10 H₂O = 4 g/L for 20 min at 85 °C, etching in 20% H₂SO₄ for 1 min at 65 °C. Between every step, the steel samples were washed with distilled water. After etching and washing with water, the samples were immersed in ethanol, and then dried. After drying, the samples were weighed (m_{before} in Eq. (1)) and etched again in 20% sulfuric acid for 2 s, then rinsed with distilled water in order to remove the oxide layer. After that, the samples were placed in pure 3% NaCl and in 3% NaCl with 0.5; 1.0; and 1.5 g/L dandelion extract, respectively, for 2, 4, 6, 24 and 48 h. After the experiments, the samples were washed and dried and weighed (m_{after} in Eq. (1)) again. The experiments were performed in triplicate and

Table 1 Chemical composition of steel samples

Steel	Element (wt. %)						Fe
	C	Mn	Sb	Si	Sn	P	
S1	0.09	0.32	0.27	0.02	0.11	0.01	rest
S2	0.10	0.29	-	0.02	-	0.01	rest

average values were used for calculation. Based on the weight loss in the steel samples for the time spent in the solutions prepared, negative mass index of corrosion, K_m^- , corrosion depth indicator, π , and corrosion inhibition efficiency η_{ML} were calculated.

The negative mass index of corrosion, K_m^- [g/(m² h)], was calculated according to:

$$K_m^- = \frac{m_{\text{before}} - m_{\text{after}}}{S_s \cdot t} \quad (1)$$

where S_s is steel sample area in m² and t is immersion time in h.

The corrosion depth indicator, π [mm/y], was determined according to

$$\pi = \frac{K_m^- \cdot 8.76}{d} \quad (2)$$

where d is steel density [g/cm³] and 8.76 is the number of hours in one year divided by 1000. This corrosion parameter is related to the metal.

The corrosion inhibition efficiency, η_{ML} (%) was evaluated according to

$$\eta_{ML} = \frac{K_{m,0}^- - K_m^-}{K_{m,0}^-} \cdot 100 \quad (3)$$

where $K_{m,0}^-$ is the negative mass index of corrosion in blank 3% NaCl, i.e. without the dandelion extract. Since two different steel samples were used, the influence of the alloying elements on steel corrosion in a saline environment was also examined through the change in the value of corrosion indicators. The efficiency of dandelion as a corrosion inhibitor was also investigated by electrochemical methods. The corrosion potential and corrosion current were determined based on the results of potentiodynamic polarization tests. Nyquist curves were also recorded using the electrochemical impedance spectroscopy (EIS) method. Corrosion measurements were performed using a potentiostat/galvanostat/ZRA Gamry Series GTM 750, in a three-electrode cell. The saturated calomel electrode was used as reference electrode, a Pt electrode was used as counter electrode, and a tested steel sample with a surface area of 1 cm² was the working electrode. The open circuit potential was recorded until a stable value was established before the electrochemical tests. The polarization plots were recorded in the range of ± 0.25 V with respect to the open circuit potential, with a recording speed of 1 mV/s. Electrochemical impedance spectroscopy was conducted over a frequency range

of 100 kHz to 10 mHz, with a 7 mV sinusoidal voltage amplitude, at open circuit potential. The corrosion current density, corrosion potential, cathodic and anodic slopes were calculated based on polarization plots using the DC Corrosion Software with the ZRA Gamry Series GTM 750 potentiostat/galvanostat. The corrosion inhibition efficiency, η_{EL} (%), was calculated based on electrochemical methods and evaluated according to:

$$\eta_{EL} = \frac{j_{\text{corr},0} - j_{\text{corr}}}{j_{\text{corr},0}} \cdot 100 \quad (4)$$

where $j_{\text{corr},0}$ and j_{corr} are corrosion current densities in the absence and in the presence of dandelion extract, respectively.

The polarization resistance, R_p (Ω cm²), is calculated according to Stern-Geary equation:

$$R_p = \frac{\beta_a \beta_c}{2.3 j_{\text{corr}} (\beta_c + \beta_a)}, \quad (5)$$

where β_a and β_c are the anodic and cathodic polarization slopes, respectively, in V, j_{corr} is the corrosion current density in A/cm².

The inhibitor efficiency η_{EIS} (%) was also calculated based on the total polarization resistance (R_{pr}) of steel obtained in inhibited and blank NaCl solutions, according to Eq. (6):

$$\eta_{EIS} = \frac{R_{pr(\text{with inhibitor})} - R_{pr(\text{blank steel surface})}}{R_{pr(\text{with inhibitor})}} \cdot 100. \quad (6)$$

The morphology and composition of the steel surfaces after 24 h in blank and inhibited NaCl solutions were examined by scanning electron microscopy (SEM) and energy dispersive X-ray spectroscopy (EDS) using a ZEISS EVO 10 microscope. The characteristics of the obtained extract and the inhibitor film formed on the steel after immersion in the inhibited solution after 24 h were studied by ATR-FTIR spectra (Agilent Technology Carry 630 FTIR). The IR spectra were recorded with a spectral resolution of 4 cm⁻¹ and in a wavenumber range of 400–4000 cm⁻¹.

3 Results and discussion

Surfaces of the steel samples after 24 h in blank and inhibited NaCl solutions were monitored by SEM and the obtained micrographs are shown in Fig. 1. As can be seen from Fig. 1 (a) and Fig. 1 (c), the morphology of S1 and S2 surfaces is heterogeneous after 24 h in pure 3% NaCl. The surface of S1 is completely covered by the flower-like corrosion products. The same pattern is also visible

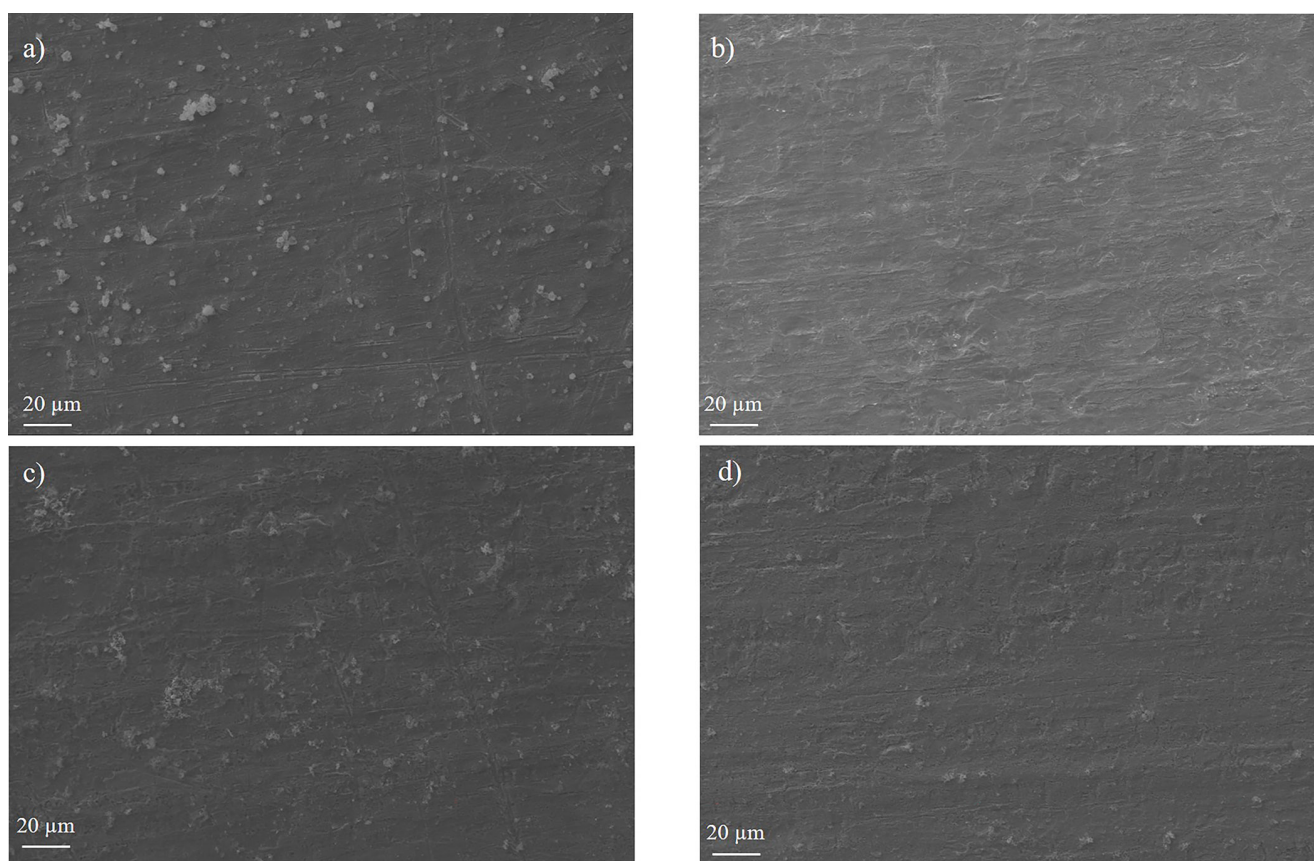

Fig. 1 SEM micrographs of (a) Steel 1 surface after 24 h in 3% NaCl, (b) Steel 1 surface after 24 h in 3% NaCl + 1.5 g/L dandelion extract, (c) Steel 2 surface after 24 h in 3% NaCl and (d) Steel 2 surface after 24 h in 3% NaCl + 1.5 g/L dandelion extract

on the surface of S2 (Fig. 1 (c)), but in a significantly smaller amount, suggesting the better corrosion stability. The presence of the inhibitor in the solution clearly influenced the corrosion process of both types of steel examined. The steel surfaces are more homogeneous, covered by a uniform inhibitor film after 24 h in 3% NaCl + 1.5 g/L dandelion root extract. The absence of the corrosion product on the surface suggests the retardation of corrosion processes by the adsorbed inhibitor species from dandelion extract. EDS results showed a significant content of carbon and oxygen on the surface of both types of steel examined after 24 h in inhibited solutions for 24 h, confirming the presence of the inhibitor film on the surface.

The FTIR spectra of dandelion root extract and S1 and S2 after 24 h in a 3% NaCl + 1.5 g/L dandelion root extract solution are shown in Fig. 2. The similarity of the spectra, both in the full spectral range (Fig. 2 (a)) and in fingerprint region (Fig. 2 (b)) is obvious, confirming the adsorption of the compounds from the extract onto the metal surface. IR bands at 3355 cm^{-1} , 1636 cm^{-1} and 1057 cm^{-1} are related to O–H, C=O and C–O, respectively. Furthermore, C–H (2928 cm^{-1}), C–N (1245 cm^{-1}) and N=C=S (2091 cm^{-1})

functional groups are present. Spectra in the fingerprint region show additional peaks in the extract below 1000 cm^{-1} , originating from alkyl-halide vibration frequencies, which are not present on the steel samples. The FTIR spectra of the steel after 24 h in inhibited solutions showed the same dominant groups as pure dandelion root extract. The O–H C=O groups were dominant, indicating that active components from extract are adsorbed onto the sample surface through these functional groups [5]. Dandelion root extract is composed of phenolic and terpene compounds, sesquiterpene lactones, fructans and inulin.

This extract can possess up to 40% of inulin [23]. In recent years, dandelion root extract has been examined as a potential adsorbent of heavy metals from wastewater. This is mostly due to the presence of inulin, which can easily adsorb metals into its structure. The obtained FTIR spectra are very similar, almost identical to the FTIR spectra of polysaccharide PD1-1 isolated from dandelion root by Guo et al. [24]. PD1-1 is an inulin-type polysaccharide and is composed of glucose (52.39%) and mannose (45.41%), with excellent antioxidant properties. Also, Fuks et al. [25] used dandelion root to adsorb Sr and Am from water, and the FTIR results

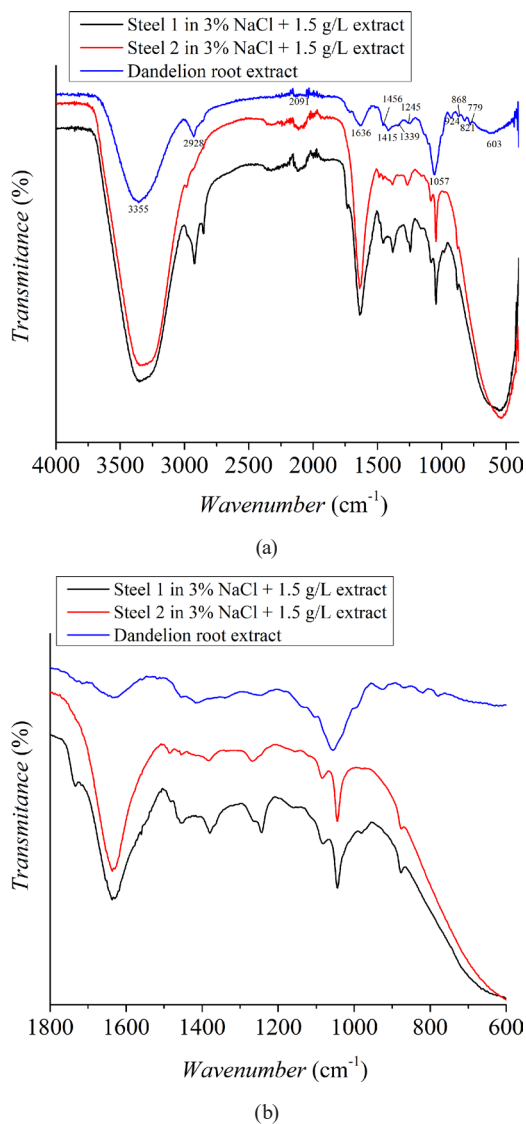

Fig. 2 FTIR spectra of dandelion root extract and Steel 1 and Steel 2 after 24 h in 3% NaCl + 1.5 g/L dandelion root extract solutions; (a) full region and (b) fingerprint region

showed that the properties of inulin dominated over other components of the dandelion root. As shown in Fig. 2, the O–H group is present on the spectra related to steel samples, thus the hydroxyl groups within the inulin molecule could be the dominant metal-complexing groups. Therefore, the adsorption properties of the dandelion root extract are most likely related to this specific site [25].

The dependence of corrosion depth indicator is presented in Fig. 3. From Fig. 3 (a) it can be seen that the values of the corrosion depth indicator for steel S1 decrease in inhibited solutions. The highest values of the corrosion depth indicator for steel samples S1 are in the uninhibited solution at all immersion times, confirming the active deterioration of steel properties in a chloride-rich

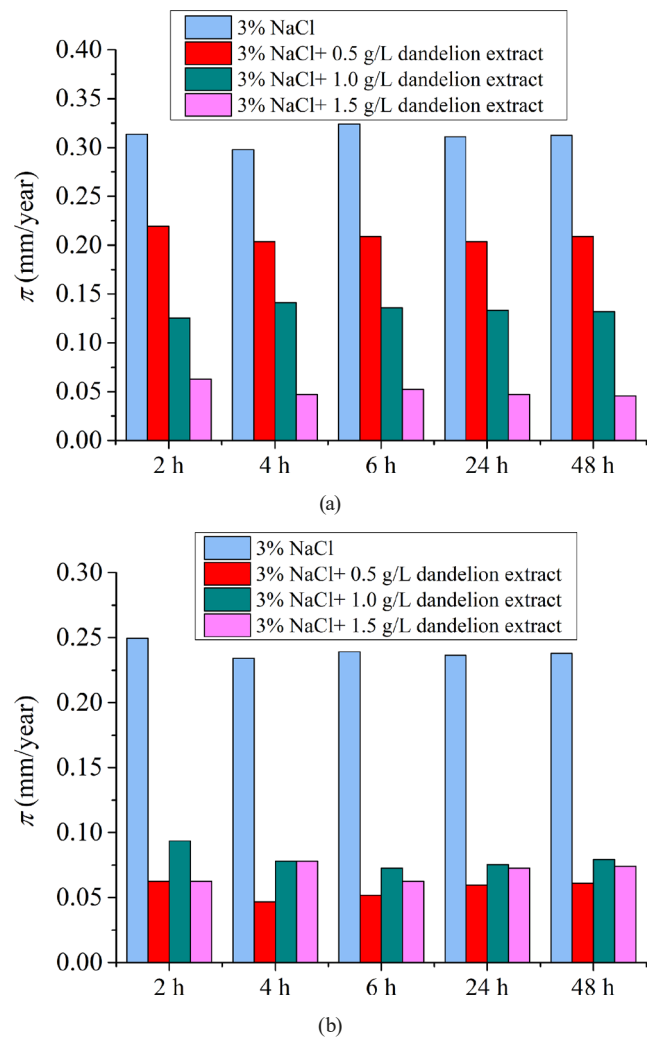

Fig. 3 Dependence of corrosion depth indicator values on time in 3% NaCl with and without dandelion extract for (a) Steel 1 and (b) Steel 2

environment. With the addition of the extract, the corrosion depth indicator values decreased more than seven times. The greatest drop in the depth indicator value is noticeable in the solution with 1.5 g/L of dandelion extract, and over the time of exposure to the corrosive environment its value was lowered, suggesting active protection of the steel by the organic molecules from the extract. The lowest value of the corrosion depth indicator is 0.0457 mm/y after 48 h in 3% NaCl + 1.5 g/L of dandelion extract.

Also, it can be noticed that the values of the corrosion depth indicator do not change significantly over time in the inhibited solutions examined, which indicates the steel surface passivation. From Fig. 3 (b) it can be seen that the values of the corrosion depth indicator for S2 samples change significantly when dandelion extract is present in 3% NaCl. Thus, the highest value of the corrosion depth indicator was in the uninhibited solution, and a significant drop in

the values of the corrosion depth indicator of steel S2 in the inhibited solutions over time was noticeable. The values of the corrosion depth indicator π for inhibited solutions ranged from 0.0468–0.0936 mm/y for all test times. This indicates that the dandelion root extract has a very good inhibitory effect on steel S2 in 3% NaCl. Fig. 4 shows the dependence between the protection factor of steel S1 (Fig. 4 (a)) and S2 (Fig. 4 (b)) in the solutions without and with dandelion extract and time. From Fig. 4 (a), it is evident that the values of the protection factor are the highest when the highest concentration of dandelion extract is used, which is 1.5 g/L, for all the exposure times tested (2, 4, 6, 24, and 48 h). At a dandelion extract concentration of 0.5 g/L, the corrosion inhibition factor does not exceed 50%, indicating that the dandelion extract cannot be used as a corrosion inhibitor for steel S1 at this concentration. The protection factor at a dandelion extract concentration

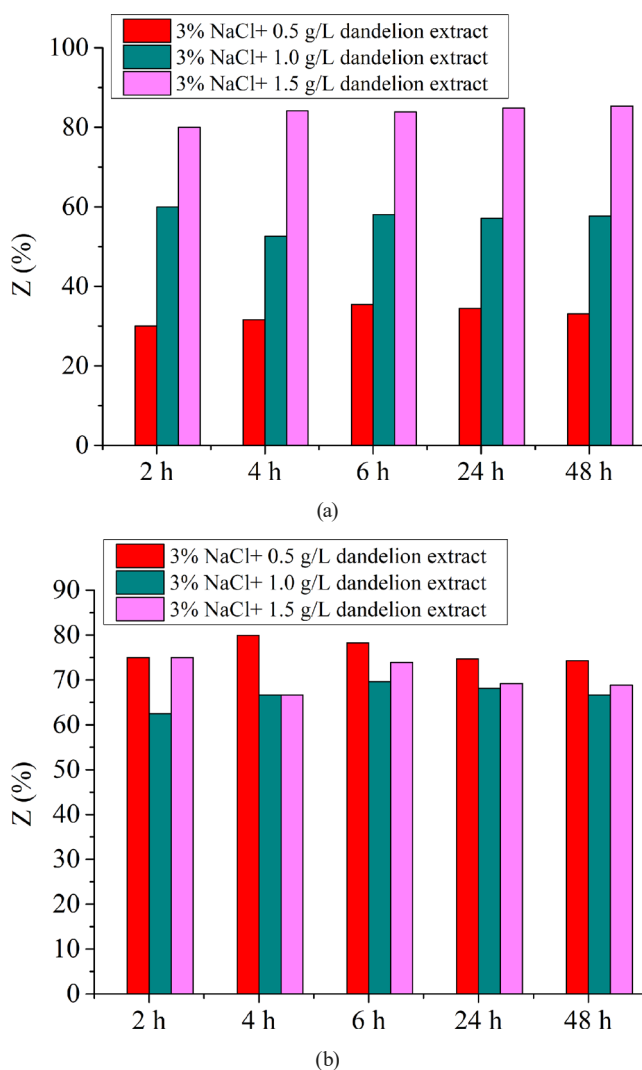

Fig. 4 Dependence of protection factor values on time in 3% NaCl with and without dandelion extract for (a) Steel 1 and (b) Steel 2

of 1.0 g/L exceeds 50%, and at a concentration of 1.5 g/L, it ranges from 80.01% to 85.35%. At these concentrations, dandelion can be effectively utilized as a corrosion inhibitor for steel S1 in a 3% NaCl solution. It is also noticeable that the corrosion inhibition factor slightly increases with time in the solution containing 1.5 g/L dandelion extract, which indicates the formation of a stable passive layer of organic compounds on the steel surface. From Fig. 4 (b), it can be observed that there is a high value of protection factor in all solutions containing dandelion extract. Also, the protection factor values did not differ significantly by changing the extract concentration. This suggests that it would be favorable to use a lower inhibitor concentration, which is very good from an economic point of view. The highest protection factor is 79.98% at a dandelion extract concentration of 0.5 g/L within a 4 h exposure time. Additionally, the highest protection factor of S2 is obtained at a 0.5 g/L extract concentration for all exposure times. The lowest protection factor is 62.51% at a dandelion concentration of 1.0 g/L for a 2 h exposure of steel S2. Also, Fig. 4 (b) demonstrates that dandelion extract is an effective corrosion inhibitor in the NaCl solution at all used concentrations, with the protection factor ranging from 62.51% to 79.98%. Furthermore, it is evident from Fig. 3 and Fig. 4 that the protection factor of the corrosion inhibitor used (dandelion extract) depends highly on the chemical composition of the steel. For steel S1, the optimal concentration of dandelion extract is 1.5 g/L, while for steel S2, the optimal concentration is 0.5 g/L. When the two tested steels are compared, it can be observed that, in the corrosive environment with lower concentration of extract, for all the exposure times tested, steel S1 exhibits a higher corrosion rate (Fig. 3) compared to steel S2, which does not contain antimony and tin as alloying elements. Fig. 5 (a) and (b) depicts the polarization plots showing the dependence between potential (E) and the logarithm of current density ($\log j$) in a 3% NaCl solution with different inhibitor concentrations for steels S1 and S2. The relevant electrochemical parameters were derived from the polarization plots, including the corrosion potential (E_{corr}), corrosion current density (j_{corr}), cathodic (β_c) and anodic slope (β_a). They are shown in Table 2 and Table 3 along with the calculated corrosion inhibition efficiency (η_{EL}) and polarization resistance.

From Fig. 5 (a) and (b), it can be observed that the obtained polarization plots do not significantly differ for S1 and S2 in 3% NaCl solutions. As can be seen from the diagrams, the addition of the inhibitor shifted both the cathodic and anodic parts of the polarization plots to lower

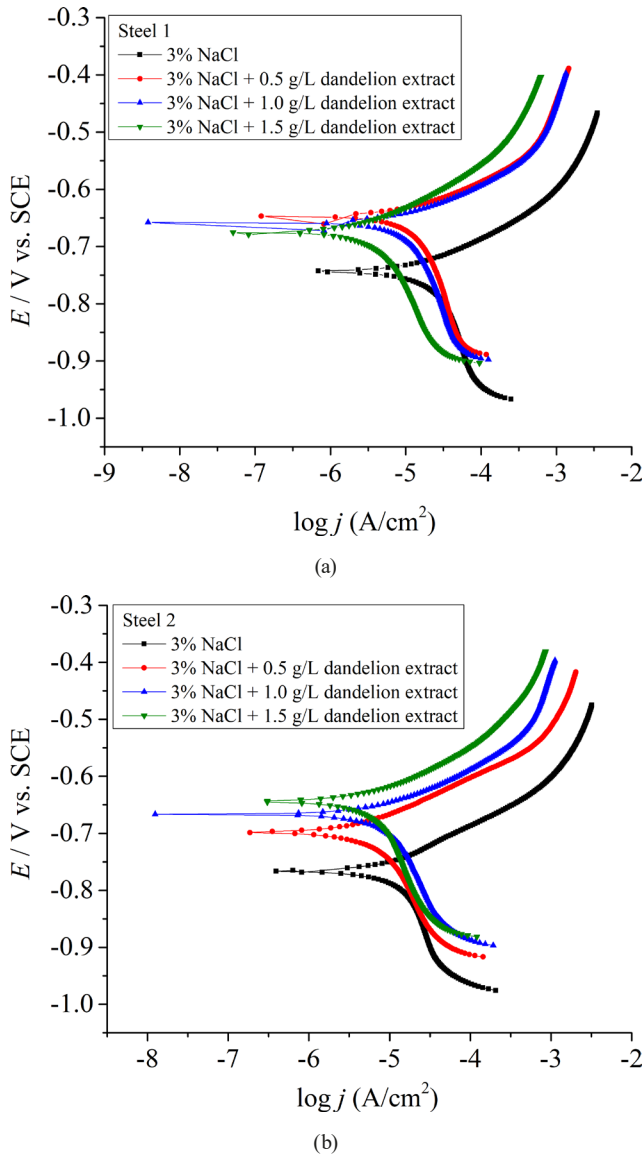

Fig. 5 Polarization plots for steel (a) S1 and (b) S2 in 3% NaCl without and with various concentrations of dandelion extract

Table 2 Calculated values of corrosion potential, corrosion current density, cathodic and anodic slope, corrosion inhibition efficiency and polarization resistance for steel S1

Steel S1						
Solution	E_{corr} (mV)	j_{corr} ($\mu A/cm^2$)	β_a (mV/dec)	β_c (mV/dec)	η_{EL} (%)	R_p (Ωcm^2)
3% NaCl	-742	8.6	138.9	78.4	-	2533.7
3% NaCl + 0.5 g/L extract	-646	5.7	76.3	65.5	33.4	2687.1
3% NaCl + 1.0 g/L extract	-657	3.6	64.8	73.4	57.6	4172.2
3% NaCl + 1.5 g/L extract	-675	1.3	61.5	55.1	84.8	9719.8

Table 3 Calculated values of corrosion potential, corrosion current density, cathodic and anodic slope, corrosion inhibition efficiency and polarization resistance for steel S2

Steel S2						
Solution	E_{corr} (mV)	j_{corr} ($\mu A/cm^2$)	β_a (mV/dec)	β_c (mV/dec)	η_{EL} (%)	R_p (Ωcm^2)
3% NaCl	-767	6.5	53.6	51.0	-	4020.6
3% NaCl + 0.5 g/L extract	-698	1.7	57.2	64.8	73.8	7770.6
3% NaCl + 1.0 g/L extract	-666	2.1	51.8	52.9	67.7	5418.7
3% NaCl + 1.5 g/L extract	-643	2.0	43.3	43.7	69.2	4730.5

corrosion current densities at all concentrations tested, resulting in a significant reduction in corrosion rate. This indicates that the anodic dissolution of steel, as well as the cathodic hydrogen evolution were reduced by the addition of dandelion root extract to the chloride solution.

Also, the shift of the anodic branch was greater than that of the cathodic branch, which may indicate that the anodic reaction was largely suppressed. As the concentration of the inhibitor increases, the observed phenomenon becomes progressively more evident. The corrosion parameters in Tables 2 and 3 suggest that dandelion had an inhibitory effect on both types of used steel, which is consistent with the results obtained by the gravimetric method. The change in the anodic and cathodic slope suggests that dandelion extract acts as a mixed corrosion inhibitor with a predominantly anodic reaction, since the presence of dandelion extract shifts the corrosion potentials towards a more positive region. The anodic inhibitors are passivating inhibitors, which means that chemical compounds present in dandelion root extract at the mentioned concentration gave the best conditions for forcing the steel into the passivation range. The anodic slope of S1 is reduced more than 50% in the presence of inhibitor. This change in slopes is a consequence of the adsorption of molecules onto the anodic areas of the steel [16]. The dandelion extract contains different chemical compounds, i.e. sugars – inulin, nystose, sucrose, fructose etc. (reducing agents, minimize the oxidative environment in the metal immersion solution), phenolic compounds – chlorogenic acid, caffeic acid, luteolin, narirutin *p*-coumaric acid, quinic acid, quercetin, etc. [3, 26]. When some of these molecules are adsorbed onto the steel, complex adsorbates are

formed, which protect the metallic surface from corrosion by retarding both the metal dissolution rate and the hydrogen evolution reaction rate. The obtained corrosion current densities and inhibitor efficiency values are in line with the results of gravimetric measurements. For S1, the lowest corrosion current density (highest inhibitor efficiency) was achieved at an extract concentration of 1.5 g/L, while for S2, it was at a concentration of 0.5 g/L, resulting in $1.3 \mu\text{A}/\text{cm}^2$ (84.8%) and $1.7 \mu\text{A}/\text{cm}^2$ (73.8%), respectively. The polarization resistance values obtained are higher for the S1, and in the solution containing 1.5 g/L of extract amounts $9179 \Omega \text{ cm}^2$ which suggest a very good corrosion inhibition effect. The Nyquist and Bode plots of S1 and S2 in the inhibited and uninhibited solutions are shown in Figs. 6 and 7. The Nyquist plots of all the samples examined show depressed semicircles, which indicate non-ideal capacitive behavior. The semicircle diameter increases

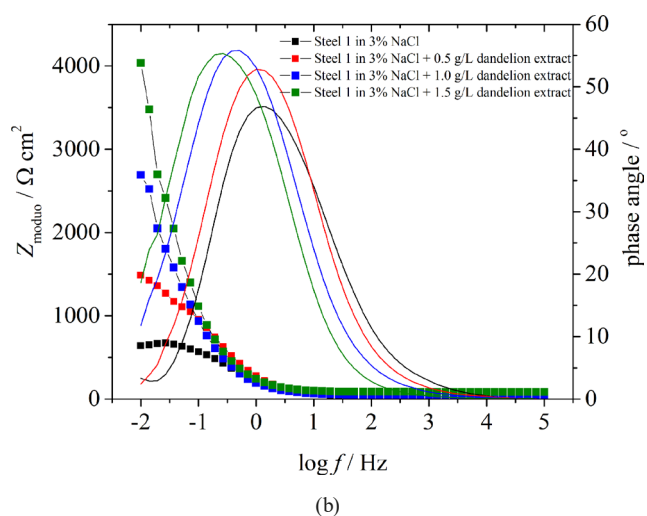
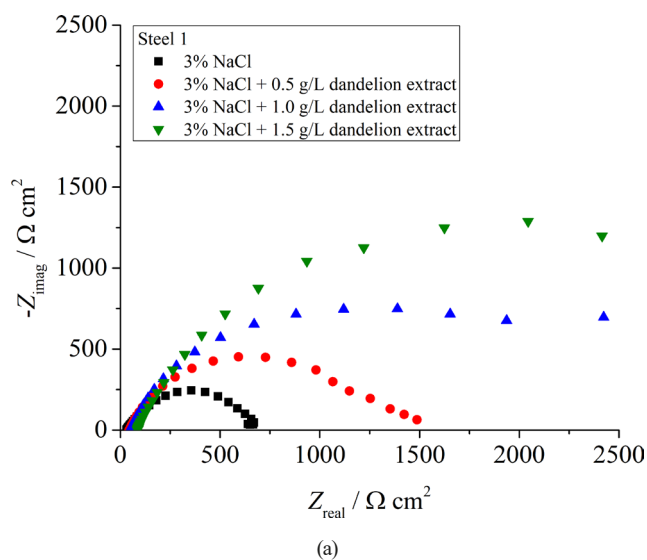

Fig. 6 Nyquist and Bode plots of Steel 1 in 3% NaCl without and with various concentrations of dandelion extract

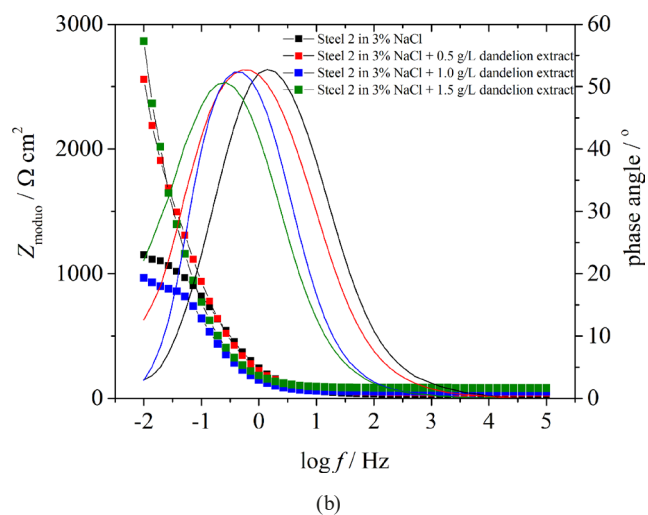
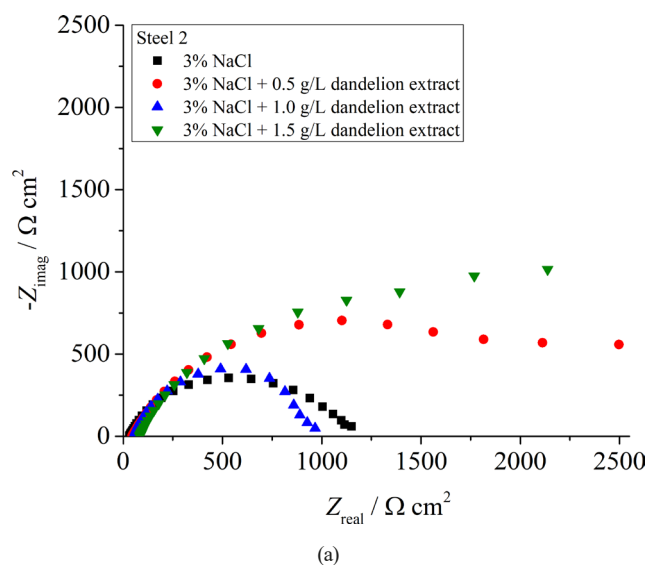

Fig. 7 Nyquist and Bode plots of Steel 2 in 3% NaCl without and with various concentrations of dandelion extract

with the increasing concentration of dandelion extract in the 3% NaCl solution, indicating a reduction in the corrosion rate. The highest corrosion resistance for both steels used is in the solution with a concentration of 1.5 g/L, where $Z_{\text{real}} > 2500 \Omega \text{ cm}^2$. An exception is S2, which is more corrosion-resistant in the solution with a concentration of 0.5 g/L compared to the solution with 1.0 g/L. Steel S2 exhibits low corrosion resistance in the 3% NaCl solution containing 1.0 g/L dandelion extract, probably due to formation of a non-uniform inhibitor film on the steel surface. The surface of the steel is covered with metal oxides/hydroxides in the NaCl solution, and the extract molecules may not adhere to the surface sufficiently. The effectiveness of inhibitors can be assessed by examining the Bode plot at low frequencies, where low impedance is associated with metal–environment interaction. Increase in the concentration of the extract in the chloride solution

increased the $Z_{mod,0.01\text{ Hz}}$ value of S1 six times, compared to $Z_{mod,0.01\text{ Hz}}$ in the uninhibited solution. The presence of dandelion extract triggered the increase in phase angle and its movement to lower frequencies, suggesting improved capacitive characteristics [6]. Thus, the plant extract present in the chloride solution affects the corrosion processes of steel by impeding oxidation and reduction reactions. In order to obtain more information about specific corrosion parameters and the role of inhibitor in the corrosion process, the EIS data were fitted to the suitable equivalent electrical circuit proposed, shown in Fig. 8. In the equivalent circuit (EEC) employed, R_s denotes the solution resistance, R_f is the resistance of the layer (either inhibitor film or corrosion products), CPE1 represents the constant phase element associated with the capacitance of the adsorbed film (C_f), CPE2 denotes the constant phase element corresponding to the double layer capacitance (C_{dl}) in parallel with the charge transfer resistance (R_{ct}). A good agreement is obtained between the proposed EEC and the measured EIS data ($\chi^2 \sim 10^{-4}$), which supports the validity of the proposed EEC. Constant phase element (CPE) is used

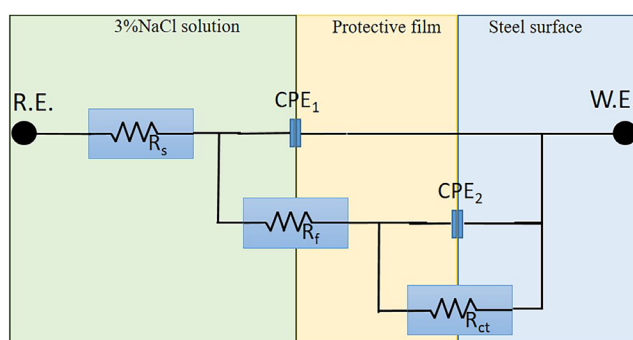

Fig. 8 Equivalent electrical circuit used for fitting the obtained EIS data (R.E. is reference electrode, and W.E. is working electrode)

instead of capacitance in the EEC proposed, since the resulting Bode diagram slopes range from 0.76 to 0.99.

The deviation from the pure capacitor ($n = 1$) is a consequence of surface roughness due to the adsorption of inhibitors, dislocation or formation of a porous layer [2, 6]. The obtained data are summarized in Table 4.

As can be seen from Table 4, the total polarization resistance (R_{pr}) increases and the capacitance of the inhibitor film decreases with higher concentrations of dandelion extract, indicating enhanced suppression of the corrosion process in steel in the presence of the inhibitor film. The total polarization resistance of steel reached the highest value of $4833\ \Omega\ \text{cm}^2$ for S1 and of $3530\ \Omega\ \text{cm}^2$ for S2 at a 1.5 g/L extract concentration, indicating an increase in the surface coverage by the inhibitor, which led to an increase in the inhibition efficiency. The obtained inhibitor efficiency values at a 1.5 g/L extract concentration based on the polarization test and those based on the EIS data are almost the same, which also confirms the proposed EEC. SEM micrographs showed the uniform inhibitor film on these samples, as shown in Fig. 1, and FTIR confirmed the presence of polysaccharides (inulin) accompanied with other phytochemicals. The corrosion inhibition effect of dandelion root extract is most likely attributed to the presence of oxygen-containing functional groups within its constituent compounds. These groups demonstrate a strong affinity for iron, facilitating adsorption onto the steel surface.

This adsorption process, primarily driven by physisorption, involves the partial sharing of electrons between oxygen atoms and the iron surface, potentially leading to the formation of a double bond [3]. Additionally, aromatic rings present in extract compounds may further enhance

Table 4 Equivalent circuit parameters for Steel 1 and Steel 2 electrode in corrosive 3% NaCl solution in the presence and absence of inhibitors

3%NaCl	R_s ($\Omega\ \text{cm}^2$)	R_{pr} ($\Omega\ \text{cm}^2$)	C_f ($\mu\text{F}/\text{cm}^2$)	n_1	C_{dl} ($\mu\text{F}/\text{cm}^2$)	n_2	η_{EIS} (%)
Bare Steel 1 surface	41.80	759.0	0.9489	0.8722	0.5692	0.8082	–
+g/L dandelion extract							
0.5	45.48	2209	0.2143	0.8071	0.2547	0.8351	65.64
1.0	49.12	2354	0.1695	0.8179	0.2735	0.8310	67.76
1.5	43.90	4833	0.0615	0.9235	0.2837	0.8482	84.29
Bare Steel 2 surface	47.25	1071	0.5378	0.8123	0.2471	0.8172	–
+g/L dandelion extract							
0.5	44.17	2344	0.0607	0.7903	0.4760	0.7695	54.31
1.0	53.12	1443	0.1007	0.9999	0.8793	0.9158	25.95
1.5	48.31	3530	0.0597	0.7826	0.7799	0.7735	69.66

binding [27]. The resulting adsorbed layer serves as a protective barrier, effectively separating the metal surface from the corrosive chloride environment. Considering the electrochemical interactions in NaCl, where the steel surface typically carries a positive charge, the initial adsorption process might involve negatively charged ions present in the given conditions. Subsequently, the positively charged compounds within dandelion extract could then bind to these adsorbed anions, forming a multi-layered protective film [3]. The adsorption of different classes of compounds onto steel surfaces, along with their synergistic effects, is responsible for improved inhibitive forces and, consequently, enhanced corrosion resistance. The good agreement between the results obtained from gravimetric measurements, potentiodynamic polarization method, and electrochemical impedance spectroscopy provides a clear picture of the efficiency of the inhibitor used.

4 Conclusions

Weight loss revealed that dandelion root extract at a concentration of 1.5 g/L inhibits the corrosion process of S1 in a 3% NaCl solution. The protection factor ranges from 80% to 85.35% at this concentration. However, at lower dandelion concentrations (1.0 g/L), the corrosion inhibition factor is approximately 50%, and at 0.5 g/L, it drops to around 30%, making it an inefficient inhibitor at these concentrations. Dandelion root extract also showed inhibitory effects on steel S2 in 3% NaCl. The corrosion inhibition

factor at a concentration of 0.5 g/L ranged from 74.32% to 79.98%. The increase in extract concentration did not significantly change the corrosion rate of S2, which suggests that it would be favorable to use a lower inhibitor concentration. The results indicate that the tested extract predominantly represses the anodic reaction and acts primarily as an anodic corrosion inhibitor. The dandelion root extract inhibited steel corrosion in a chloride-rich environment by adsorption of different classes of compounds onto the steel surface, and their synergism is responsible for improved corrosion properties. The EIS results obtained revealed that the resistance to the corrosion process increases with increasing the concentration of dandelion extract in 3% NaCl, suggesting a reduction in the corrosion rate and confirming the inhibitory effect of dandelion extract. The results indicate that different steels behave differently under the same conditions, emphasizing the need to assess their performance in a given environment before selecting them as construction materials. Future research will be focused on determination of the specific organic molecules responsible for the inhibitive effect.

Acknowledgment

The Ministry of Civil Affairs of Bosnia and Herzegovina (Grant No.VM 05-07-1-3483-34/23) and Ministry of Scientific and Technological Development and Higher Education of Republic of Srpska (Grant No. 19.032/431-1-34/23) are gratefully acknowledged for funding this research.

References

- [1] Sheydaei, M. "The Use of Plant Extracts as Green Corrosion Inhibitors: A Review", *Surfaces*, 7(2), pp. 380–403, 2024. <https://doi.org/10.3390/surfaces7020024>
- [2] Dent, M., Fuchs-Godec, R. "Sage Extract as a Natural Source of Corrosion Inhibitor for Tinplate in 3.0 % NaCl", *Food Technology & Biotechnology*, 59(4), pp. 413–421, 2021. <https://doi.org/10.17113/ftb.59.04.21.7026>
- [3] Deyab, M. A., Guibal, E. "Enhancement of corrosion resistance of the cooling systems in desalination plants by green inhibitor", *Scientific Reports*, 10(1), 4812, 2020. <https://doi.org/10.1038/s41598-020-61810-9>
- [4] Žbulj, K., Bilić, G., Hrnčević, L., Simon, K. "Potential of using plant extracts as green corrosion inhibitors in the petroleum industry", *Rudarsko-geološko-naftni zbornik*, 36(5), pp. 131–139, 2021. <https://doi.org/10.17794/rgn.2021.5.12>
- [5] Žbulj, K., Hrnčević, L., Bilić, G., Simon, K. "Dandelion-root extract as green corrosion inhibitor for carbon steel in CO₂-saturated brine solution", *Energies*, 15(9), 3074, 2022. <https://doi.org/10.3390/en15093074>
- [6] Zomorodian, A., Bagonyi, R., Al-Tabbaa, A. "The efficiency of eco-friendly corrosion inhibitors in protecting steel reinforcement", *Journal of Building Engineering*, 38, 102171, 2021. <https://doi.org/10.1016/j.jobbe.2021.102171>
- [7] Pepe, A., Tito, F. R., Mandri, A. D., Dommarco, R. C., Pepe, A. "Green corrosion inhibitor for mild steel extracted from soybean leaves", *Chemical Engineering Communications*, 211(5), pp. 697–706, 2024. <https://doi.org/10.1080/00986445.2023.2284732>
- [8] Lasri, M., Zefzoufi, M., Byadi, S., Soubhy, M., Idouhli, R., Khadiri, M. E., Abouelfida, A., Fdil, R. "Studies of genistein as green corrosion inhibitor isolated from *R. monosperma* flowers", *Chemical Papers*, 78(3), pp. 1915–1930, 2024. <https://doi.org/10.1007/s11696-023-03215-2>
- [9] Hussein, S. A., Khadom, A. A. "Okra leaves extract as green corrosion inhibitor for steel in sulfuric acid: Gravimetric, electrochemical, and surface morphological investigations", *Results in Chemistry*, 8, 101566, 2024. <https://doi.org/10.1016/j.rechem.2024.101566>

- [10] Zunita, M., Rahmi, V. A. "Advancement of Plant Extract/Ionic Liquid-Based Green Corrosion Inhibitor", *Chemistry Africa*, 7(2), pp. 505–538, 2024.
<https://doi.org/10.1007/s42250-023-00782-5>
- [11] Al Salihi, H. A., Mahdi, R. R., Al-Amiery, A., Al-Azzawi, W. K., Kadhum, A. A. H. "Exploring the Efficacy of Polysaccharides as Green Corrosion Inhibitors: A Comprehensive Review", *Starch-Stärke*, 76(7–8), 2300234, 2024.
<https://doi.org/10.1002/star.202300234>
- [12] Barboza, G. K. P., de Oliveira, M. C. C., Neves, M. A., Echevarria, A. "*Justicia brandegeana* as a green corrosion inhibitor for carbon steel in sulfuric acid", *Green Chemistry Letters and Reviews*, 17(1), 2320254, 2024.
<https://doi.org/10.1080/17518253.2024.2320254>
- [13] Dehghani, A., Ghahremani, P., Mostafatabar, A. H., Ramezanzadeh, B. "Plant extracts: Probable alternatives for traditional inhibitors for controlling alloys corrosion against acidic media—A review", *Biomass Conversion and Biorefinery*, 14(6), pp. 7467–7486, 2024.
<https://doi.org/10.1007/s13399-022-02893-4>
- [14] Oulabbas, A., Abderrahmane, S., Salcı, A., Geçibesler, İ. H., Solmaz, R. "Adsorption and corrosion inhibition of Cactus cladode extract and effect of KI addition on mild steel in 0.5 M H₂SO₄", *ChemistrySelect*, 7(19), e202200212, 2022.
<https://doi.org/10.1002/slct.202200212>
- [15] Bhardwaj, N., Sharma, P., Kumar, V. "Phytochemicals as steel corrosion inhibitor: an insight into mechanism", *Corrosion Reviews*, 39(1), pp. 27–41, 2021.
<https://doi.org/10.1515/corrrev-2020-0046>
- [16] Salcı, A., Yüksel, H., Solmaz, R. "Experimental studies on the corrosion inhibition performance of 2-(2-aminophenyl) benzimidazole for mild steel protection in HCl solution", *Journal of the Taiwan Institute of Chemical Engineers*, 134, 104349, 2022.
<https://doi.org/10.1016/j.jtice.2022.104349>
- [17] Kenny, O., Smyth, T. J., Walsh, D., Kelleher, C. T., Hewage, C. M., Brunton, N. P. "Investigating the potential of under-utilised plants from the Asteraceae family as a source of natural antimicrobial and antioxidant extracts", *Food Chemistry*, 161, pp. 79–86, 2014.
<https://doi.org/10.1016/j.foodchem.2014.03.126>
- [18] Ostovari, A., Hoseinieh, S. M., Peikari, M., Shadizadeh, S. R., Hashemi, S. J. "Corrosion inhibition of mild steel in 1 M HCl solution by henna extract: A comparative study of the inhibition by henna and its constituents (Lawson, Gallic acid, α-D-Glucose and Tannic acid)", *Corrosion Science*, 51(9), pp. 1935–1949, 2009.
<https://doi.org/10.1016/j.corsci.2009.05.024>
- [19] Durak, T., Depciuch, J. "Effect of plant sample preparation and measuring methods on ATR-FTIR spectra results", *Environmental and Experimental Botany*, 169, 103915, 2020.
<https://doi.org/10.1016/j.envexpbot.2019.103915>
- [20] Nowak, A., Duchnik, W., Zielonka-Brzezicka, J., Muzykiewicz, A., Florkowska, K., Klimowicz, A., Kucharski, Ł., Wysocka, D., Dziedzic, A. "The antioxidant activity of ethanolic and aqueous extracts of dandelion (*Taraxacum officinale* L.)", *Pomeranian Journal of Life Sciences*, 65(4), pp. 83–88, 2019.
<https://doi.org/10.21164/pomjlifesci.639>
- [21] Bu, U., Me, O., To, M. "Phytochemical constituents of *Taraxacum officinale* leaves as eco-friendly and nontoxic organic inhibitors for stainless steel corrosion in 0.2 M HCl acid medium", *International Journal of Chemical Science*, 2(6), pp. 35–43, 2018.
- [22] Li, H., Fan, M., Wang, K., Bian, X., Jiang, H., Ding, W. "Traditional Chinese medicine extracts as novel corrosion inhibitors for AZ91 magnesium alloy in saline environment", *Scientific Reports*, 12(1), 7367, 2022.
<https://doi.org/10.1038/s41598-022-10900-x>
- [23] Nuridullaeva, K. N., Karieva, E. S., Khalilov, R. M. "Development of Industrial Technology of Inulin Production from Dandelion Roots (*Taraxacum officinale* Wigg.)", *Pharmaceutical Chemistry Journal*, 57(8), pp. 1298–1303, 2023.
<https://doi.org/10.1007/s11094-024-03038-9>
- [24] Guo, H., Zhang, W., Jiang, Y., Wang, H., Chen, G., Guo, M. "Physicochemical, structural, and biological properties of polysaccharides from dandelion", *Molecules*, 24(8), 1485, 2019.
<https://doi.org/10.3390/molecules24081485>
- [25] Fuks, L., Oszczak, A., Dudek, J., Majdan, M., Trytek, M. "Removal of the radionuclides from aqueous solutions by biosorption on the roots of the dandelion (*Taraxacum officinale*)", *International Journal of Environmental Science and Technology*, 13(10), pp. 2339–2352, 2016.
<https://doi.org/10.1007/s13762-016-1067-3>
- [26] Satapathy, A. K., Gunasekaran, G., Sahoo, S. C., Amit, K., Rodrigues, P. V. "Corrosion inhibition by *Justicia gendarussa* plant extract in hydrochloric acid solution", *Corrosion Science*, 51(12), pp. 2848–2856, 2009.
<https://doi.org/10.1016/j.corsci.2009.08.016>
- [27] Hau, N. N., Huong, D. Q. "Effect of aromatic rings on mild steel corrosion inhibition ability of nitrogen heteroatom-containing compounds: Experimental and theoretical investigation", *Journal of Molecular Structure*, 1277, 134884, 2023.
<https://doi.org/10.1016/j.molstruc.2022.134884>