

NUMERICAL APPLICATIONS OF THE PYRAMID MODEL OF SUBGRADE ANALYSIS

By

S. KALISZKY-GY. GALASKÓ

Department of Civil Engineering Mechanics, Technical University, Budapest

(Received: July 15, 1976)

1. Introduction

The exact analysis of structures resting on subgrade involves great mathematical difficulties. In order to reduce these difficulties, various mathematical and mechanical models have been suggested for the subgrade that have been applied for the solution of different problems (e.g. [1, 2, 3]). Among these models, the *pyramid model* is little known and not widely used. Although the idea of this model in the literature goes back to the beginning of this century, it was only later that I. I. KANDAUROV suggested first the use of the pyramid model for the investigation of elastically supported structures and presented an analytical method [4, 5].

Independent of KANDAUROV's work, the same model has been invented and developed at the Department of Civil Engineering Mechanics, Technical University, Budapest [6]. Still, at a difference from [4, 5], because this research has aimed at the *numerical analysis* of structures resting on a subgrade. Besides, computers have permitted the investigation of more sophisticated problems such as elasto-plastic, inhomogeneous subgrade and space structures.

The aim of this paper is to survey the possibilities of the numerical application of the pyramid model for the investigation of various structural problems.

2. Plane problems

2.1. Description of the model

Most subgrade models in the literature and in practice replace the whole supporting elastic continuum by a single elastic layer. In the WINKLER model this layer consists of independent elements (springs), while in the models proposed by P. L. PASTERNAK, V. Z. VLASSOV, M. M. FILONENKO-BORODICH and E. C. TING also the interaction between the elements (springs) is taken into consideration [7, 8, 9] (Fig. 1).

None of these models is suitable for the calculation of the stresses and strains of the supporting continuum. These shortcomings cannot be eliminated

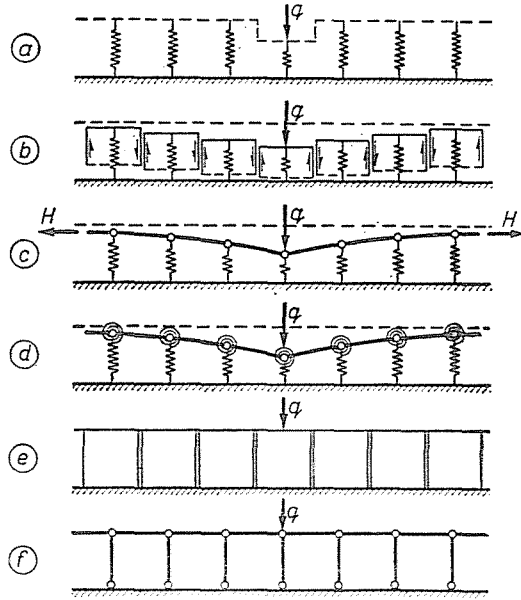

Fig. 1

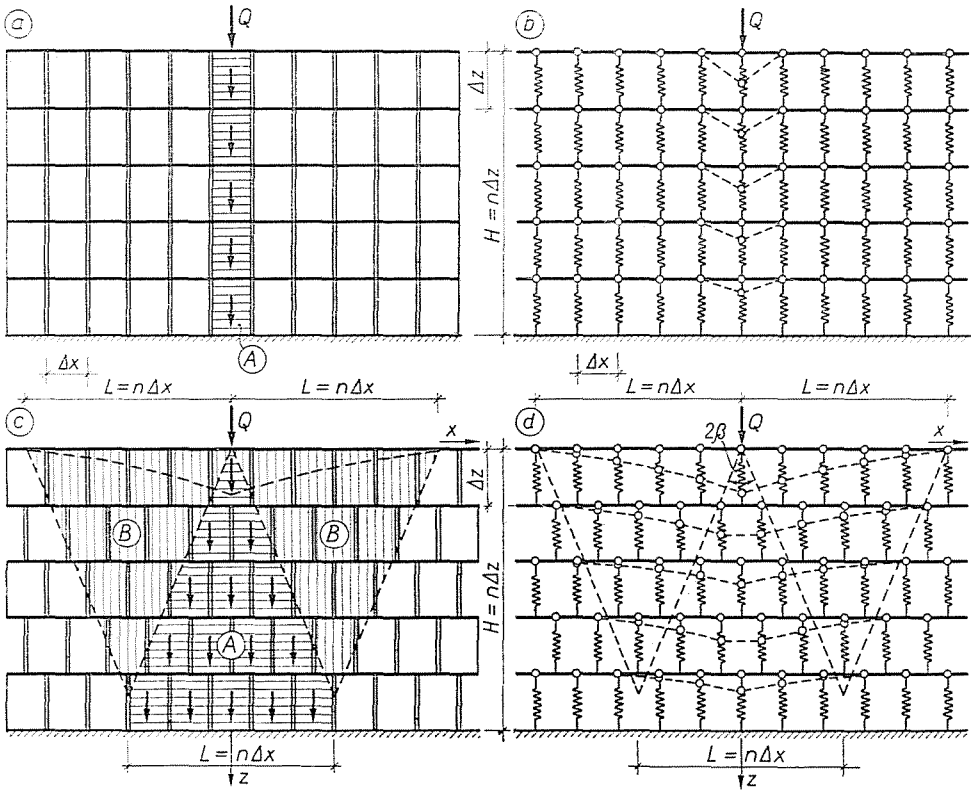

Fig. 2

even by replacing the subgrade by several elastic layers (Fig. 2a—b). Let us suppose now that alternate elastic layers are shifted relative to each other in such a way that their arrangement and behaviour are similar to those of a brick wall (Fig. 2c). Neglecting the interaction between the elements in the same layer, a new mechanical model can be constructed with a skeleton consisting of horizontal rigid bars supported by vertical elastic springs (Fig. 2d).

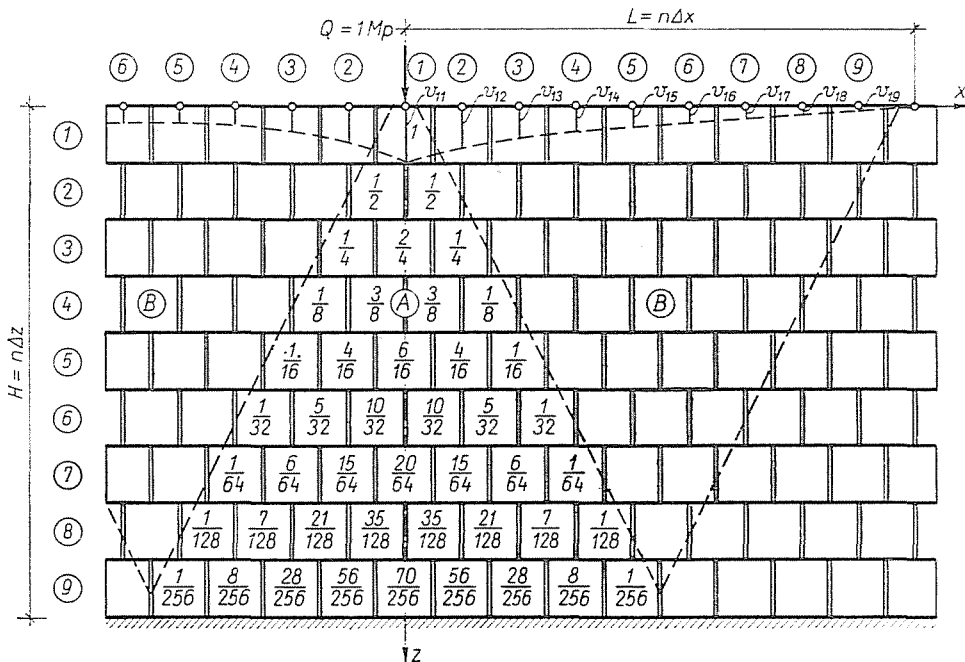

Fig. 3

A force acting on this model spreads in a triangular domain similarly to the force distribution in a pyramid. This is why this model is called a pyramid model. In the "active" domain "A" the force is distributed in the depth $H = n\Delta z$ along the width $L = n\Delta x$. In this domain the springs are compressed and the rigid bars undertake displacements. In the "passive" domains "B" the springs are not stressed, but as a consequence of rigid-body motions, the horizontal boundary line of these parts along the distance $L = n\Delta x$ undertake vertical displacements. Thus, in this model the interaction between the pressures and displacements of the horizontal boundary line is extended over the distance L (Fig. 3).

2.2. Analytical and numerical application of the model

Using the pyramid model the mechanical behaviour of a linear elastic subgrade can be characterized by the coefficient k of the springs composing the mechanical model. Supposing that the supporting elastic continuum is in a state of plane strain, this coefficient is:

$$k = \frac{E}{1 - \nu^2} \frac{\Delta x \Delta y}{\Delta z}, \quad (1)$$

while, in the state of linear strain:

$$k = \frac{1 - \nu}{1 - \nu - 2\nu^2} E \frac{\Delta x \Delta y}{\Delta z}. \quad (2)$$

Here E is the Young's modulus and ν is the Poisson's ratio of the subgrade. Formulae (1) and (2) are valid for plane and space problems, respectively.

Let us assume now that the subgrade is subjected to a single unit load $Q = 1$, and calculate the forces in the springs and the vertical displacements of the horizontal boundary line. In the "active" domain of the subgrade the spring forces are easy to calculate since the rigid bars are simply supported beams. The results up to 9 layers are illustrated in Fig. 3. The sum of these forces in each layer is identical and the numerators of the fractions expressing these forces are given by the binomial coefficients of the *Pascal* triangle. KANDAUROV found the same results [4] and expressed the spring force P_{mn} belonging to the n -th row and m -th column in the form:

$$P_{mn} = \binom{n}{m} \left(\frac{1}{2}\right)^m \left(\frac{1}{2}\right)^{n-m}$$

Then, he approximated this formula by the Gaussian function:

$$P_{mn} \approx \sqrt{\frac{2}{\pi n}} e^{-\frac{2}{n} \left(m - \frac{n}{2}\right)^2}. \quad (3)$$

and introduced the variables $m = \frac{x}{a}$ and $n = \frac{z}{b}$. In this way he obtained a function providing continuous distribution for the spring-forces, likely to serve as basis of a relatively simple analytical investigation of elastically supported structures.

Comparing the values of the approximate function (3) with the coefficients of Fig. 3, along the vertical line of the active force the function (3) can be stated to closely approach the exact coefficients, but at a longer distance from the force the discrepancy may be great (e.g. about 50% in case of 10 layers at the extreme springs). This latter error little affects, however, the

results, therefore the analytical method elaborated by KANDAUROV provides good approximate results.

In practice there are many problems which can only be treated by numerical methods. Then, instead of function (3), the coefficients of Fig. 3 provide a simple basis for the determination of the vertical displacements of the boundary line due to a unit force acting on the subgrade. In plane problems the vertical displacement at i caused by the unit force acting at 1 is given by

$$v_{1i} = \frac{1}{k} \sum_C S_j^Q \cdot S_j^P. \tag{4}$$

Here S_j^Q and S_j^P are spring-forces due to unit forces $Q = 1$ and $P = 1$ acting at 1 and i , respectively, and the summation is extended to the common part of the two active domains belonging to forces Q and P (area denoted by C in Fig. 2c). The results of these calculations for various numbers of layers are presented in Table 1. These displacements give directly the influence coefficients needed in the force method, because, for a given number of layers, one can construct the flexibility matrix F of the subgrade using data in Table 1. The inverse of F gives, on the other hand, the stiffness matrix: $K = F^{-1}$.

Table 1

Number of layers n	Enlarged displacements due to force $P = 1$ Mp (kr_{1i})								
	The place of displacement (i)								
	1	2	3	4	5	6	7	8	9
1	1								
2	$\frac{6}{4}$	$\frac{1}{4}$							
3	$\frac{30}{16}$	$\frac{8}{16}$	$\frac{1}{16}$						
4	$\frac{140}{64}$	$\frac{47}{64}$	$\frac{10}{64}$	$\frac{1}{64}$					
5	$\frac{630}{256}$	$\frac{244}{256}$	$\frac{68}{256}$	$\frac{12}{256}$	$\frac{1}{256}$				
6	$\frac{2772}{1024}$	$\frac{1186}{1024}$	$\frac{392}{1024}$	$\frac{93}{1024}$	$\frac{14}{1024}$	$\frac{1}{1024}$			
7	$\frac{12012}{4096}$	$\frac{5536}{4096}$	$\frac{2063}{4096}$	$\frac{592}{4096}$	$\frac{122}{4096}$	$\frac{16}{4096}$	$\frac{1}{4096}$		
8	$\frac{51480}{16384}$	$\frac{25147}{16384}$	$\frac{10254}{16384}$	$\frac{3369}{16384}$	$\frac{852}{16384}$	$\frac{155}{16384}$	$\frac{18}{16384}$	$\frac{1}{16384}$	
9	$\frac{218790}{65536}$	$\frac{112028}{65536}$	$\frac{49024}{65536}$	$\frac{18004}{65536}$	$\frac{5228}{65536}$	$\frac{1180}{65536}$	$\frac{192}{65536}$	$\frac{20}{65536}$	$\frac{1}{65536}$

Table 2

$$F = \begin{bmatrix} \frac{30}{16} & \frac{8}{10} & \frac{1}{16} & 0 & 0 & 0 & 0 & 0 \\ \frac{8}{16} & \frac{30}{16} & \frac{8}{16} & \frac{1}{16} & 0 & 0 & 0 & 0 \\ \frac{1}{16} & \frac{8}{16} & \frac{30}{16} & \frac{8}{16} & \frac{1}{16} & 0 & 0 & 0 \\ 0 & \frac{1}{16} & \frac{8}{16} & \frac{30}{16} & \frac{8}{16} & \frac{1}{16} & 0 & 0 \\ \frac{1}{k} & 0 & 0 & \frac{1}{16} & \frac{8}{16} & \frac{30}{16} & \frac{8}{16} & \frac{1}{16} \\ 0 & 0 & 0 & \frac{1}{16} & \frac{8}{16} & \frac{30}{16} & \frac{8}{16} & \frac{1}{16} \\ 0 & 0 & 0 & 0 & \frac{1}{16} & \frac{8}{16} & \frac{30}{16} & \frac{8}{16} \\ 0 & 0 & 0 & 0 & 0 & \frac{1}{16} & \frac{8}{16} & \frac{30}{16} \end{bmatrix}$$

$$K = \begin{bmatrix} .57512 & -.15964 & -.02364 & -.00082 & -.00062 & .00020 & -.00003 & .00000 \\ -.15964 & .61943 & -.16620 & .02387 & -.00065 & -.00068 & .00021 & -.00003 \\ .02364 & -.16620 & .62040 & -.16624 & .02384 & -.00064 & -.00068 & .00020 \\ -.00082 & .02387 & -.16624 & .62040 & -.16624 & .02384 & -.00065 & -.00062 \\ -.00062 & -.00065 & .02384 & -.16624 & .62040 & -.16624 & .02387 & -.00082 \\ .00020 & -.00068 & -.00064 & .02384 & -.16624 & .62040 & -.16620 & .02364 \\ -.00003 & .00021 & -.00068 & -.00065 & .02387 & -.16620 & .61943 & -.15964 \\ .00000 & -.00003 & .00020 & -.00062 & -.00082 & .02364 & -.15964 & .57512 \end{bmatrix}$$

(Inverting the matrix F , one has to take into consideration the points lying outside the structure, see Table 2.) These two matrices can be incorporated into the flexibility or stiffness matrix of the whole structure and then the problem can be analyzed by either the force or the displacement method. According to our experience, to take into consideration the elastic behaviour of the subgrade in the described method little increases the running time compared with that of the structure with rigid supports.

Besides of the analysis of structures supported on an elastic subgrade, the pyramid model is also suitable for the determination of the distribution of the vertical stresses arising in the elastic continuum. Fig. 3 provides the spring forces due to unit loads acting on the subgrade from which — knowing the pressure distribution under the structure — the spring forces, hence the vertical stresses can be determined at any point. The calculation of the displacements of the continuum is done similarly.

2.3. A few special problems

The main advantage of numerical methods is to permit the analysis of complicated problems, which could not be treated by analytical methods. This

is the advantage of the application of the pyramid model, too. In the following a few examples will be presented.

a) Let us consider an *inhomogeneous subgrade*, where the Young's modulus E is a function of z and thus, the spring coefficient k is not constant but may differ for each layer. This fact has to be taken into consideration in Eq. (4) for the vertical displacements of the boundary line due to unit force. There is another way, however, to take into account the inhomogeneity of the subgrade. Namely, instead of the coefficient k one can consider the thickness of the layers Δz as a variable value. This is illustrated in Fig. 4. Notice that this latter method does not yield the same result as using variable spring coefficients; its application is still recommended, since it takes into consideration the fact that the active force is distributed over a broad range of rigid subgrade, and over a narrow range of softer subgrade.

b) The pyramid model lends itself for problems where *the subgrade is not infinite, but is bounded by a vertical plane*. Then, in the neighbourhood of the bounding plane the subgrade model can be constructed in different manners, as it is illustrated in Fig. 5. For example, in the case of Fig. 5c, which seems to be the most suitable solution, the boundary of the subgrade is really a vertical plane, but the width of the elements and consequently the spring coefficients have different values along the vertical boundary line and therefore the spring forces have to be calculated for cantilever beams. The results of this calculation for 9 layers are presented in Figs 6 to 8. Having the spring forces, the displacements of the horizontal boundary line can also be determined in the way described before. The only difference is that the spring coefficient of the elements of width $\frac{1}{2} \Delta x$ is $\frac{1}{2} k$ and therefore the first few rows of the stiffness matrix are different from that presented before, such as:

		<i>6 layers</i>						
	18432	4768	640	32				
	4768	8636	3417	1146	276	42	3	
	640	3417	8314	3557	1176	279	42	3...
	32	1146	3557	8316	3558	1176	279	42...
		276	1176	3558	8316	3558	1176	279...
		42	279	1176	3558	8316	3558	1176...
		3	42	279	1176	3558	8316	3558...
			
$\frac{1}{18432.k}$								

c) The pyramid model is easy to apply for the analysis of *a bar embedded in an elastic continuum* (Fig. 9). For the sake of simplicity, let us suppose that the bar is perfectly rigid and the continuum can be described by a plane pyramid model. Then, the unknown quantities are the pressures q_i on the surface of the bar, the rotation φ and horizontal displacement c of the bar, yielding

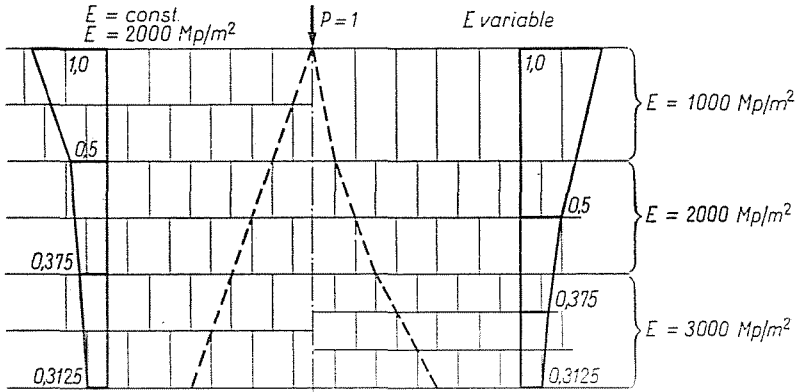

Fig. 4. - - - - active region of σ_z ; ——— distribution of stress σ_z

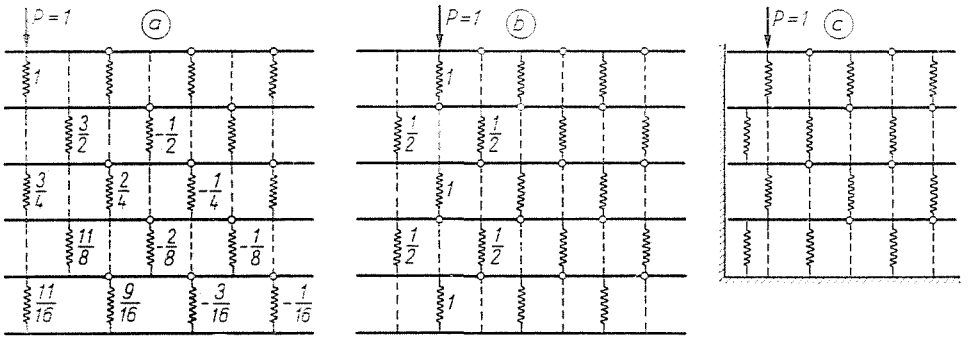

Fig. 5

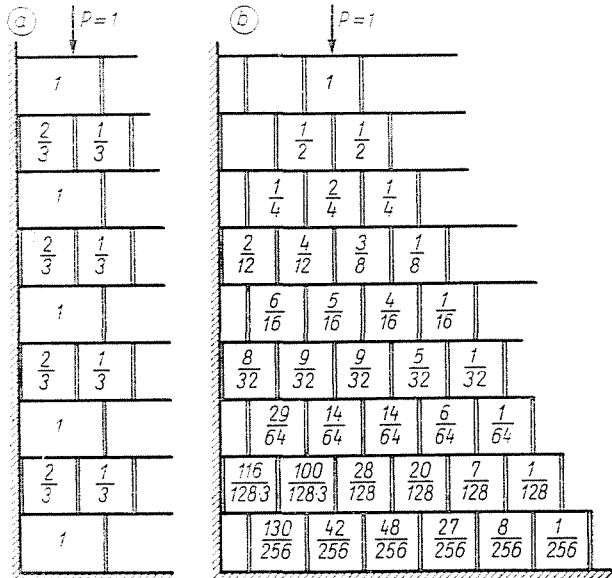

Fig. 6

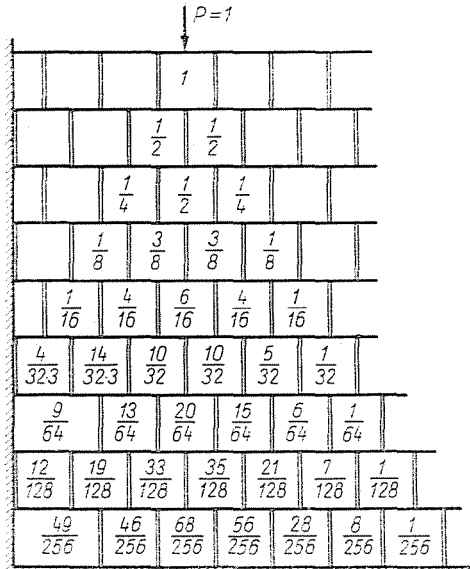

Fig. 7

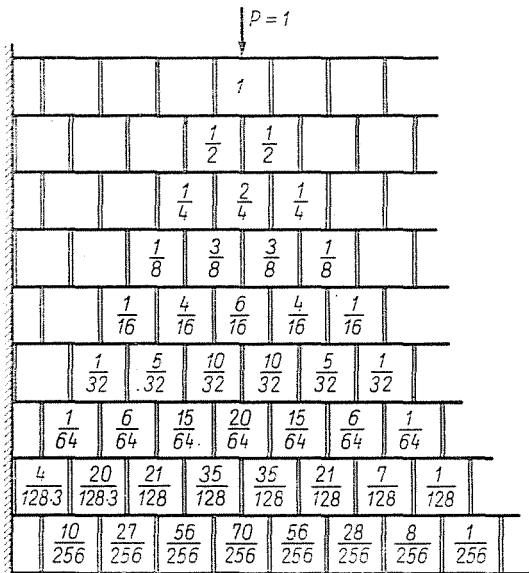

Fig. 8

the following equilibrium equations:

$$\sum_{i=1}^n q_i + P = 0$$

$$\sum_{i=1}^n q_i a(i-1) - Pb = 0.$$

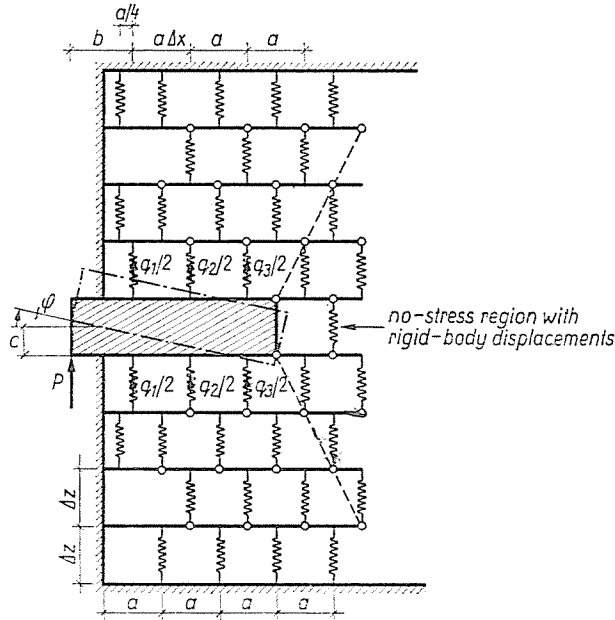

Fig. 9

The horizontal displacements can be expressed in terms of φ and c and, at the same time, of surface pressures q_j as:

$$v_i = c + a(i - 1) = \sum_{j=1}^n f_{ij} q_j \quad (i = 1, 2, \dots, n).$$

Here f_{ij} denotes the elements of the stiffness matrix of the subgrade bounded by two planes discussed in the previous chapter. For example, using 3 layers yields the following five equations:

$$\begin{aligned} q_1 + q_2 + q_3 &= -P \\ aq_2 + 2aq_3 &= bP \\ c + f_{11}q_1 + f_{12}q_2 + f_{13}q_3 &= 0 \\ c + a\varphi + f_{21}q_1 + f_{22}q_2 + f_{23}q_3 &= 0 \\ c + 2a\varphi + f_{31}q_1 + f_{32}q_2 + f_{33}q_3 &= 0 \end{aligned}$$

or, in matrix form:

$$\begin{bmatrix} \mathbf{0} & \mathbf{G} \\ \mathbf{G}^* & \mathbf{F} \end{bmatrix} \begin{bmatrix} u \\ q \end{bmatrix} = \begin{bmatrix} Q \\ O \end{bmatrix}.$$

Solution of these equations yields the displacement and surface pressures of the bar and from the latter the horizontal stresses arising in the continuum can also be calculated.

The pyramid model permits to take the flexibility of the embedded bar into consideration. The equations are, however, somewhat more complicated than those above.

3. Space problems

Let us divide an elastic half space by horizontal and vertical planes into elements. Shifting the horizontal layers in both directions x and y , as for the plane model, results in the three-dimensional version of the pyramid model. The skeleton of this model consists of rigid rectangular plates supported at their corners by springs (Fig. 10). Because of symmetry, the spring forces are equal to a quarter of the force acting at the plate center.

Suppose now the boundary surface of the subgrade to be loaded by a unit force $P = 1$. Then, using the simple rule mentioned above, the spring forces are easy to determine and are given in Fig. 11. These coefficients provide the three-dimensional version of the Pascal triangle.

The next step is to calculate the vertical displacements of the points of the boundary surface, using Eq. (4). Now the summation has to be extended over the common domains of the pyramids belonging to unit forces P and Q . The results are given in Fig. 12. With these coefficients the flexibility matrix \mathbf{F} and the stiffness matrix $\mathbf{K} = \mathbf{F}^{-1}$ of the subgrade are easy to construct and then any kind of space structures (plates, shells, grillages etc.) resting on an elastic support can be analyzed by the force or displacement method.

In *axially symmetric problems* cubic elements are advisably replaced by prismatic elements with hexagonal basis. Then, the skeleton of this model is constructed of hexagonal plates supported on three corners by springs. Using this hexagonal model the spring forces in the subgrade and the vertical displacements of the boundary surface due to the unit force can be calculated as shown in Figs 13 and 14.

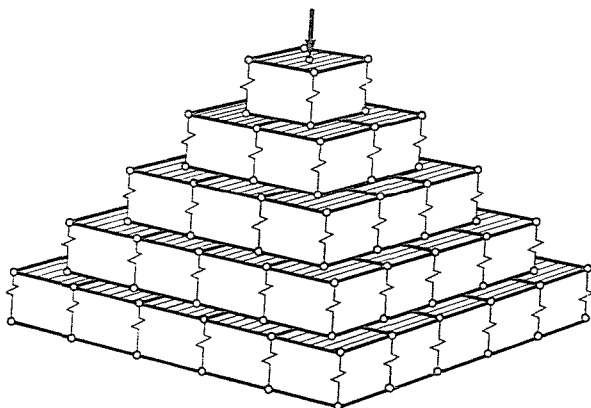

Fig. 10

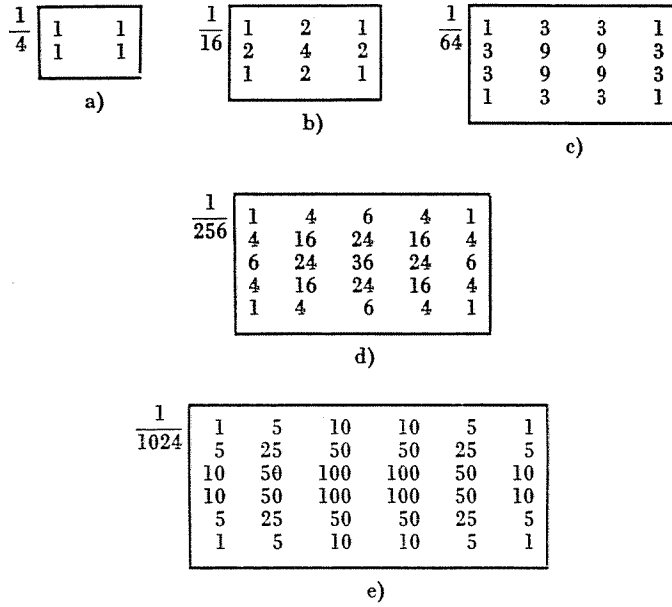

Fig. 11

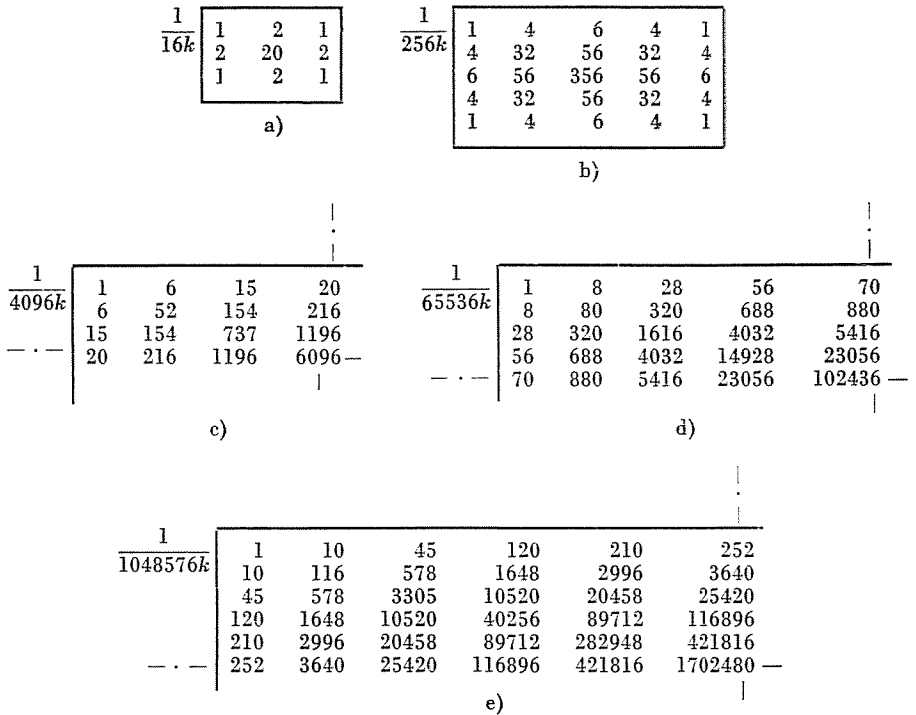

Fig. 12

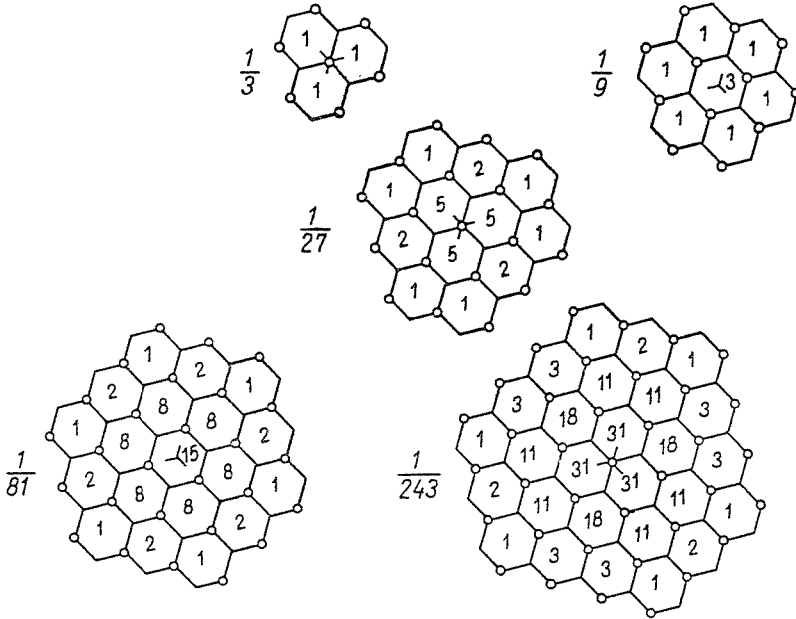

Fig. 13

Also prismatic elements with triangular bases can be used. Then the spring forces are very close to those in the hexagonal model. In the numerical analysis, however, some difficulties arise, therefore we omit the presentation of the spring forces and displacement coefficients of this model.

4. Elasto-plastic subgrade

Using the pyramid model it is very simple to take into consideration the plastic behaviour of the subgrade. In this case the skeleton of the model is unchanged, but the springs have plastic properties. Thus, supposing a strain-hardening material, the force-displacement diagram of the springs is given by Fig. 15. If the subgrade is elastic-perfectly plastic, the ratio $\frac{E'}{E}$ has to be chosen very low.

Considering the distribution of the spring forces in Fig. 3, it is evident that when different forces act on the subgrade, the springs under the highest force will be the first to yield. For the case of monotonic increasing one-parameter loading and perfectly plastic subgrade, the flow chart determining the order of springs to yield is seen in Fig. 16.

For a spring force at yield point Q_F , the spring constant changes to $k' = \frac{E'}{E} k$ and the displacement formula becomes $u_i^{pl} = u_i^{el} \frac{E}{E'}$. Accordingly,

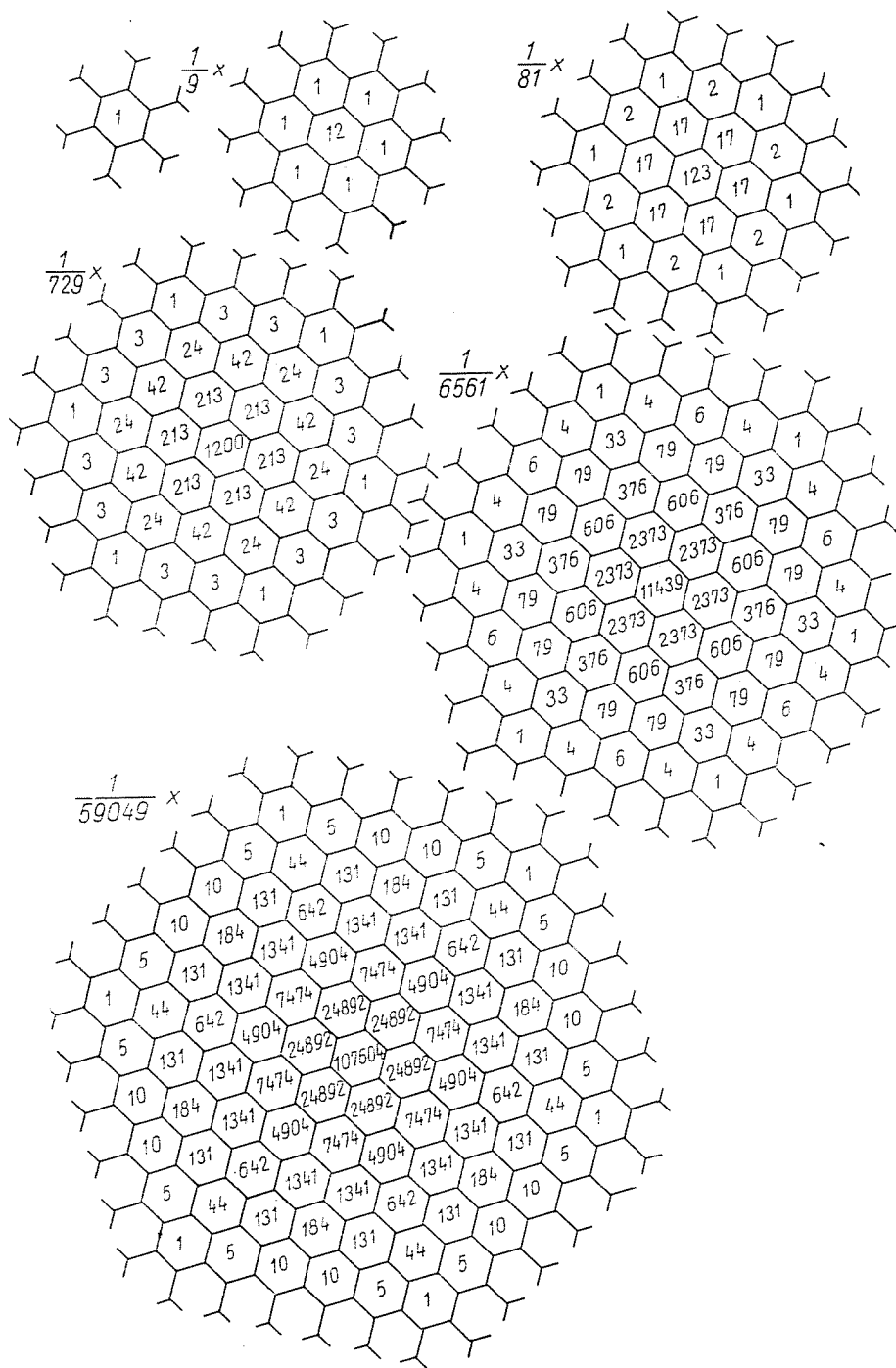

Fig. 14

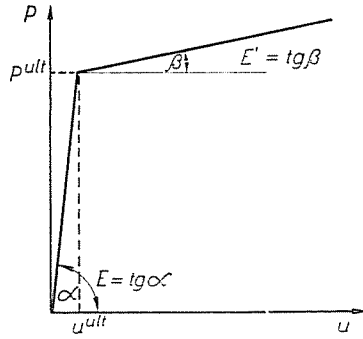

Fig. 15

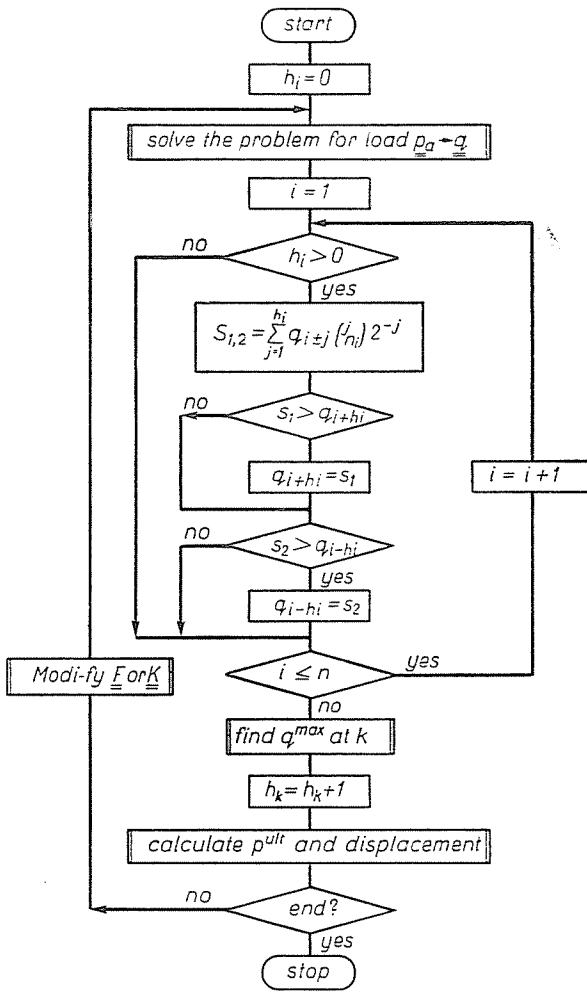

Fig. 16

the corresponding element of the flexibility matrix has to be changed. By this manner one can follow step-by-step the increase of the plastic regions of the subgrade and for a structure of perfectly plastic material the load-bearing capacity of the whole system can be determined.

5. Numerical examples

a) The first example is a two-storey, symmetrical frame shown in Fig. 17. Considering the vertical displacements obtained by different theories, the results of the pyramid model are seen to best fit the Ohde solution, considered as the most exact theory, while the displacements from the Winkler theory are rather deviating. Increasing the number n of layers in the pyramid model still improves the accuracy and the use of six layers already yields a satisfactory solution. (This is true for any numerical example where the number n of the layers is changed and the width of the elements is kept constant.)

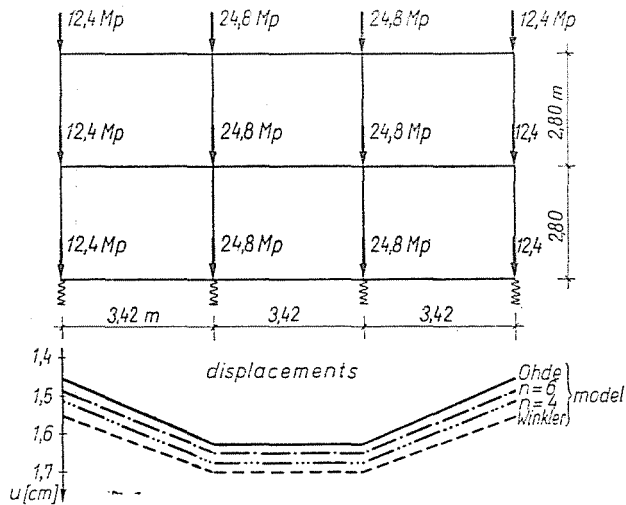

Fig. 17

The assumed number of the subgrade elements under the structure has a significant influence on the distribution of the internal forces of the structure. Increasing this number improves the accuracy of the distribution (Fig. 18).

b) The rigid bar embedded in an elastic continuum has been investigated by using the finite element method and the pyramid model. The stress distribution obtained in this manner is shown in Fig. 19.

c) The general layout of a grillage and the vertical displacements of the subgrade are illustrated in Fig. 20. The results plotted in solid line have been obtained on the basis of the Boussinesq theory [10].

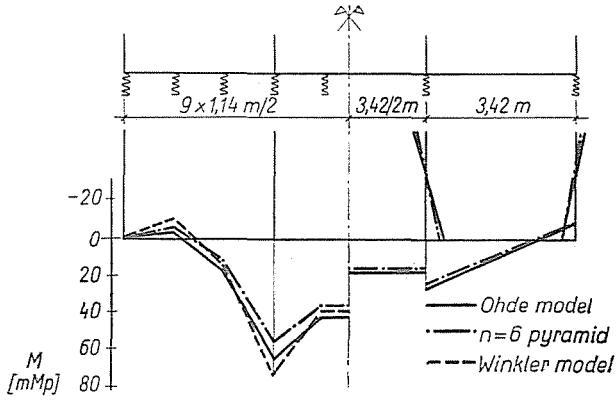

Fig. 18

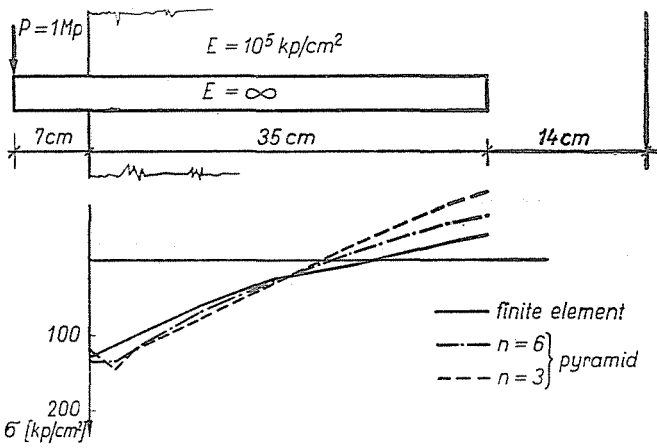

Fig. 19

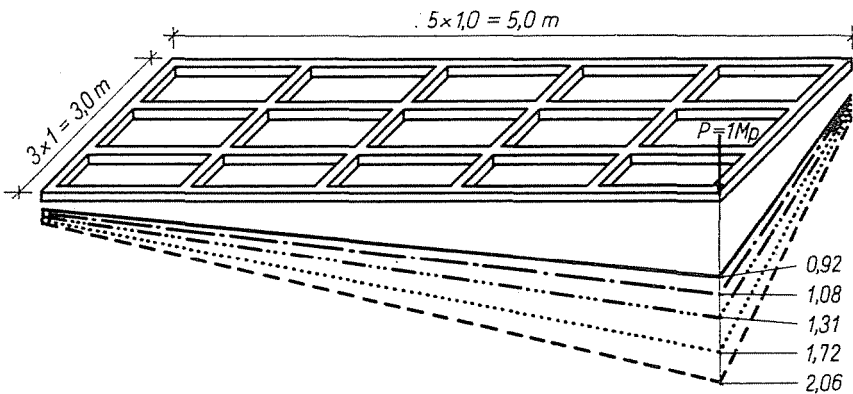

Fig. 20. $E_{\text{beam}} = 10^5 \text{ kp/cm}^2$; $E_{\text{subg}} = 100 \text{ kp/cm}^2$; $\nu = 0.2$;
 displacement (mm):
 ———— Boussinesq
 - - - - - Winkler
 number of layers:
 $n = 2$
 - - - - - $n = 4$
 - - - - - $n = 6$

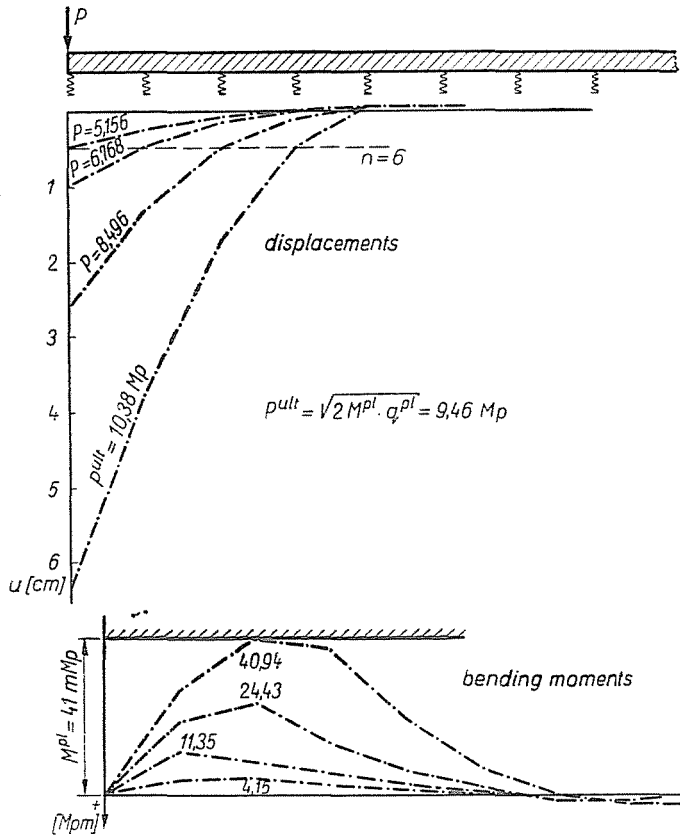

Fig. 21

d) The last example is an elastic-perfectly plastic beam resting on an elastic-perfectly plastic subgrade. Increasing the external force one can calculate the load parameters where another element of the subgrade becomes plastic. The corresponding bending moment distributions are illustrated in Fig. 21. The limit load calculated by the generalized Winkler theory [11] is $P^{\text{ult}} = 9.46 \text{ Mp}$, while the result obtained by the pyramid model is: $P^{\text{ult}} = 10.38 \text{ Mp}$.

6. Conclusions

The examples presented show the wide range of applications of the pyramid model. The model is especially suitable for numerical analysis. It provides more accurate results than the approximate methods used before in the practice, and in addition it permits to determine the vertical displacements and stresses in any point of the subgrade. Besides, the calculation is much simpler than by the exact methods, and the model is suitable for investigating

special problems such as elasto-plastic or/and inhomogeneous subgrade, bars embedded in an elastic or plastic continuum, and subgrades bounded by horizontal and vertical planes.

Summary

The pyramid model of a subgrade consists of horizontal layers divided into independent elements in such a way that their arrangement and behaviour are similar to those of a pyramid. This model is especially suitable for numerical analysis. It provides more accurate results than the other approximate methods and permits to determine the stresses and strains in the subgrade. The calculation is simple and the model is suitable for the analysis of elasto-plastic or/and inhomogeneous subgrades, bars embedded in a continuum and subgrades bounded by horizontal and vertical planes. The paper presents the application of the pyramid model to the problems above and illustrates the results of calculations on a few examples.

References

1. BOUSSINESQ, J.: Application des potentiels à l'Etude de l'Equilibre et du Mouvement des Solides élastiques. Paris 1885.
2. KORENEV, B. G.: Voprosi rascheta balok i plit na uprugom osnovanii. Moscow 1954.
3. KANY, M.: Beams on Elastic Foundation. The University of Michigan Press. 1965.
4. KANDAUROV, I. I.: *Mechanika reshnistikh sred i ego primeneniye v stroitelstve*. Moscow 1960.
5. KANDAUROV, I. I.: *K teorii raspredeleniya napriazhenii v zernistom gruntovom osnovanii*. Moscow 1960.
6. KALISZKY, S.—GALASKÓ, GY.: A New Model for the Elastic Subgrade.* Mélyép. Szemle 7. XXV. 1975.
7. FILONENKO-BORODICH, M. M.: Prosteishaia model uprugogo osnovania sposobnaia raspredelyat nagruzki. Sb. Trudov MEMIIT 53.
8. VLASSOV, V. Z.—LEONTEV, N. N.: Balki, pliti, oblochki na uprugom osnovanii. Moscow. Gostroizdat 1960.
9. TING, E. C.: Unified Formulation of Two-parameter Foundation Model, ZAMM, H. 10, Bd. 53, 1973.
10. HUNYADI, F.—ROLLER, B.—SZENTIVÁNYI, B.: Some Problems of Elastic Bedding Calculation.* Mélyép. Szemle XXIV/Y12. 1975.
11. KALISZKY, S.: Load Carrying Capacity of Plastic Beams and Plates on Plastic Foundation. Archiwum Inzynierii Ladowej — Tom. VI-Z. 1962.

* In Hungarian.

Prof. Sándor KALISZKY, D. T. Sc., }
 Gyula GALASKÓ } H-1502 Budapest