

DETERMINATION OF QUASI-STATIONARY ELECTROMAGNETIC FIELDS IN FERROMAGNETIC CONDUCTORS BY VARIATIONAL METHOD

A. IVÁNYI

Department of Theoretical Electricity,
Technical University, H-1521 Budapest

Received Oct. 20, 1984

Presented by Prof. Dr. I. Vágó

Summary

The paper gives a method for the determination of the quasi-stationary electromagnetic fields brought about by a harmonically varying current flowing in a ferromagnetic conductor of arbitrary cross section. Nonlinearity is neglected and a two-dimensional model is employed. The quasi-stationary field in the conductor is obtained by the solution of the differential equation for the vector potential at homogeneous Dirichlet boundary condition. The method presented yields a solution satisfying the differential equation approximately and the boundary conditions on the analytical or analytically approximated bounding curve exactly. The determination of the function satisfying the differential equation is reduced by variational calculus to finding the extremal function of a complex functional. Applying Ritz's procedure, the potential function is approximated by a function series. The approximating functions are constructed with the aid of R -functions to ensure that they satisfy the boundary conditions exactly. The method is illustrated by an example.

Introduction

The present paper deals with the determination of the quasi-stationary electromagnetic field brought about by a harmonically varying current flowing in a conductor of an arbitrary cross section. The material of the conductor is assumed to be highly permeable, nonlinearity is however neglected. The magnetic field is presumed not to leave the ferromagnetic medium. The problem examined is two-dimensional. The curve bounding the cross section of the conductor is assumed to be analytical or to be approximated by an analytical curve. Complex notation is used for harmonic time variation. The determination of the quasi-stationary field in the conductor leads to the solution of a differential equation related to the vector potential at Dirichlet boundary condition.

Several methods are found in the literature for solving the differential equation obtained for the vector potential at various boundary conditions. The methods of integral equations, of finite elements and of global elements are the most frequently used procedures. These methods yield solutions satisfying the

differential equation approximately and the boundary conditions either approximately or exactly. The quasi-stationary field of a non-ferromagnetic conductor has been determined at the above assumptions in [8] and [9].

The solution obtained in this paper satisfies the differential equation approximately and the boundary conditions exactly. A variational method with global approximation is employed [3], [4]. The determination of the function satisfying the differential equation is reduced to finding the extremal function of the complex functional given in [8]. Applying Ritz's procedure, the potential function is approximated by a function series. *R*-functions are used to ensure that the coordinate functions satisfy the boundary conditions exactly.

The approximation of the method is presented in an example. A desk computer has been used for numerical computations. In knowledge of the solution, the current density and flux distribution in the cross section of the conductor has been plotted.

Introduction of the vektor potential. Boundary conditions

Consider a conductor of arbitrary cross section (Fig. 1.a). The material of the conductor is of conductivity σ and permeability μ . In the isolator surrounding the conductor $\sigma_0=0$ and $\mu_0 \ll \mu$. No magnetic saturation is assumed to occur, thus the nonlinearity of the ferromagnetic conductive medium is neglected. A harmonic current $i(t)=I_0 \cos \omega t$ is flowing in the conductor in axial direction. The axial variation of the electromagnetic field is neglected, thus obtaining a two-dimensional problem of translational symmetry. In Fig. 1.b, Ω denotes the cross section of the conductor (the planar region examined) and Γ is its bounding curve. To enable the application of *R*-functions, Γ is presumed to be analytical or to be approximated by an analytical curve. The magnetic field in the ferromagnetic medium induced by the displacement current density outside the conductor is neglected.

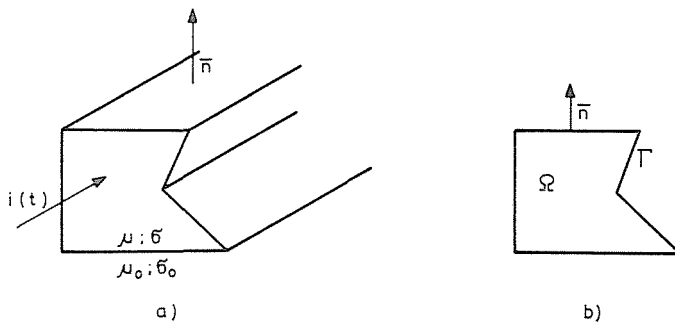

Fig. 1

The electromagnetic field in the conductor is quasi-stationary. The equations describing it are obtained from Maxwell's equations [1], [2]. The vector potential is introduced by

$$\mathbf{B} = \text{curl } \mathbf{A}, \quad (1)$$

as usual.

The problem investigated being two-dimensional, the vector potential \mathbf{A} has but one component: $\mathbf{A} = A(x, y) \mathbf{e}_z$ where z is the axial direction. Since no variation is presumed to take place in direction z :

$$\text{div } \mathbf{A} = 0. \quad (2)$$

Electrical field intensity can be obtained as

$$\mathbf{E} = -j\omega \mathbf{A} \quad (3)$$

whereas \mathbf{A} is the solution of the differential equation [1]:

$$\frac{1}{\mu} \text{curl curl } \mathbf{A} = \mathbf{J}. \quad (4)$$

In (4)

$$\mathbf{J} = \mathbf{J}_v \quad \text{or} \quad \mathbf{J} = -j\omega \sigma \mathbf{A} \quad (5)$$

if the current density distribution in the conductor is given as $\mathbf{J} = \mathbf{J}_v$ or if it is unknown.

The boundary conditions to be satisfied by \mathbf{A} are obtained by the following considerations.

Due to the high permeability of the conductor, no flux is assumed to leave the ferromagnetic medium. Thus, the curve Γ (Fig. 1.b) is a magnetic line of force. This means that flux density has a tangential component only on the curve, its component normal to the curve is zero:

$$\mathbf{Bn}|_{\Gamma} = 0 \quad (6)$$

where \mathbf{n} is the outer normal of Γ . Since the field components are expressed with the aid of the vector potential, this boundary condition is formulated for \mathbf{A} . Taking (1) into account:

$$\text{curl } \mathbf{A} \mathbf{n}|_{\Gamma} = \left(\mathbf{n} \frac{\partial A}{\partial \tau} - \tau \frac{\partial A}{\partial n} \right) \mathbf{n}|_{\Gamma} = \frac{\partial A}{\partial \tau} \Big|_{\Gamma} = 0 \quad (7)$$

where τ is the tangential unit vector of Γ . Hence, the vector potential is constant along the curve Γ :

$$\mathbf{A}|_{\Gamma} = A_0 \mathbf{e}_z. \quad (8)$$

This is a Dirichlet boundary condition for the vector potential [3], [8]. The constant A_0 is not determined by the equations therefore it can be freely selected. The most simple choice being to take A_0 zero, a homogeneous Dirichlet boundary condition is prescribed for the vector potential:

$$\mathbf{A}|_r = \mathbf{0}. \quad (9)$$

Construction of the solution

Decomposition of the field

The application of variational methods to the solution of the differential equation (4) with the current density unknown leads to numerical problems at low values of the angular frequency ω . The current density in the conductor is, according to (3) and Ohm's law:

$$\mathbf{J} = -j\omega\sigma\mathbf{A}. \quad (10)$$

In case the total current of the conductor is given, low values of ω result in high vector potential values which may cause overflow on digital computers. This problem can be eliminated by decomposing the electromagnetic field into the sum of a sourceless and a curlless part as in [11] and [8].

The equations of the sourceless and curlless field, the introduction of the vector potential as well as the differential equations governing it are given in detail in [8] and [9]. Accordingly, the differential equation to be solved is

$$\frac{1}{\mu} \text{curl curl } \mathbf{A} = \mathbf{J}_0 - j\omega\sigma\mathbf{A} \quad (11)$$

where \mathbf{J}_0 is a current density of uniform distribution which is assumed to be known in the course of the differential equation. In knowledge of the vector potential solving (11) at the boundary condition (9), flux density is obtained from (1), electrical field intensity is

$$\mathbf{E} = \mathbf{J}_0/\sigma - j\omega\mathbf{A} \quad (12)$$

and the current density in the conductor is

$$\mathbf{J} = \mathbf{J}_0 - j\omega\sigma\mathbf{A}. \quad (13)$$

At the solution of the problem, the current of the conductor is thought to be prescribed. Its value is, according to (13):

$$I_0 \mathbf{e}_z = \int_{\Omega} (\mathbf{J}_0 - j\omega\sigma\mathbf{A}) d\Omega \quad (14)$$

where I_0 is the complex amplitude of the harmonic current flowing in the conductor. The value of the parameter \mathbf{J}_0 in the differential equation (11) is to be chosen to have the Eq. (14) fulfilled.

Application of the variational method

The solution of the differential equation (11) is reduced by variational considerations to the determination of the extremal function of the complex functional

$$W(\mathbf{A}, \tilde{\mathbf{A}}) = \int_{\Omega} [(\mu\mathbf{J}_0 - j\mu\sigma\omega\mathbf{A})\tilde{\mathbf{A}} - \mathbf{curl} \mathbf{A} \mathbf{curl} \tilde{\mathbf{A}}] d\Omega \quad (15)$$

introduced in [8] where $\tilde{\mathbf{A}}$ denotes complex conjugate. The one-dimensional, complex vector potential of two variables is approximated according to Ritz's method by a linear combination of the first n elements of an entire function set [5]:

$$\mathbf{A} \approx \mathbf{A}_n = \mathbf{e}_z \sum_{k=1}^n a_k f_k(x, y) w_D(x, y) \quad (16)$$

where $f_k(x, y)$, $k = 1, 2, \dots, n$ is the k -th element of the approximating function set, $w_D(x, y)$ is a function constructed with the aid of R -functions [13], [14]. $w_D(x, y)$ ensures that each term in the approximating series satisfies the homogeneous, Dirichlet boundary condition (9) prescribed for the vector potential. Accordingly, $w_D(x, y)$ must be selected so that it is a twice differentiable function of positive value in the interior of the studied region, and zero on the curve Γ bounding the region:

$$\begin{aligned} w_D(x, y) &> 0, & \text{if } (x, y) \in \Omega \\ w_D(x, y) &= 0, & \text{if } (x, y) \in \Gamma \end{aligned} \quad (17)$$

The coefficients a_k , $k = 1, 2, \dots, n$ in (16) are complex quantities.

Substituting the approximating sum (16) into the functional (15) and differentiating the functional with respect to \tilde{a}_k , $k = 1, 2, \dots, n$, the complex column vector \mathbf{a} of the coefficients can be derived as a function of the parameter \mathbf{J}_0 from the equation

$$(\mathbf{M}_r + j\omega\mu\sigma\mathbf{M}_i)\mathbf{a} = \mu\mathbf{J}_0\mathbf{N}. \quad (18)$$

In (18), the square matrices \mathbf{M}_r and \mathbf{M}_i are of order n , and i -th element of their k -th row is

$$\mathbf{M}_r(k, l) = \int_{\Omega} \mathbf{curl} (w_D f_k \mathbf{e}_z) \mathbf{curl} (w_D f_l \mathbf{e}_z) d\Omega \quad (19)$$

and

$$\mathbf{M}_i(k, l) = \int_{\Omega} (w_D f_k)(w_D f_l) d\Omega \quad (20)$$

respectively. The k -th element of the n -order column vector \mathbf{N} in (18) is

$$\mathbf{N}(k) = \int_{\Omega} w_D f_k d\Omega. \quad (21)$$

Applying the approximation (16), the current of the conductor is, using (14):

$$I_0 = J_0 \Omega - j\omega\sigma \int_{\Omega} \sum_{k=1}^n f_k w_D a_k d\Omega \quad (22)$$

Taking (21) into account, this current is

$$I_0 = J_0 \Omega - j\omega\sigma \mathbf{N}^+ \mathbf{a} \quad (23)$$

which allows J_0 to be expressed and eliminated from (18):

$$\left[\mathbf{M}_r + j\omega\mu\sigma \left(\mathbf{M}_i - \frac{1}{\mu} \mathbf{N}\mathbf{N}^+ \right) \right] \mathbf{a} = \mu I_0 \frac{1}{\Omega} \mathbf{N}. \quad (24)$$

In the precedings, $+$ denotes transposition.

Illustration of the method. Presentation of results

Numerical calculations have been carried out for the I cross section conductor shown in Fig. 2. The conductivity of the conducting medium has been chosen as $\sigma = 1/160 \cdot 10^9$ S/m and its relative permeability as $\mu_r = 40$.

With the geometrical dimensions $a = b = 30$ mm, $d = 10$ mm, the analysis has been carried out at frequencies $f = 0, 50, 100, 150$ and 200 Hz and with an exciting current $I_0 = 2000$ A.

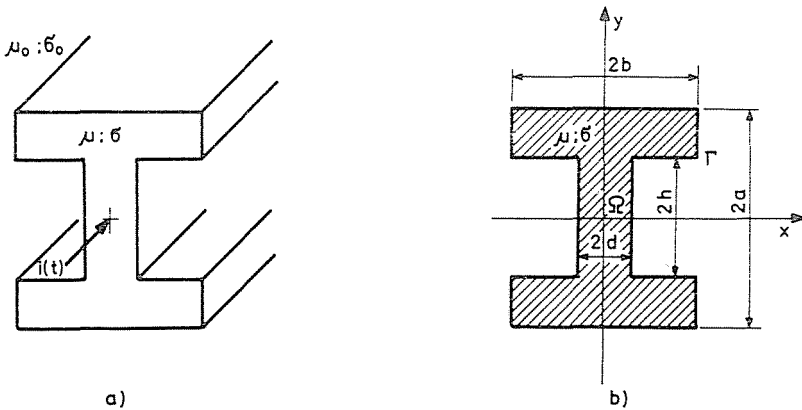

Fig. 2

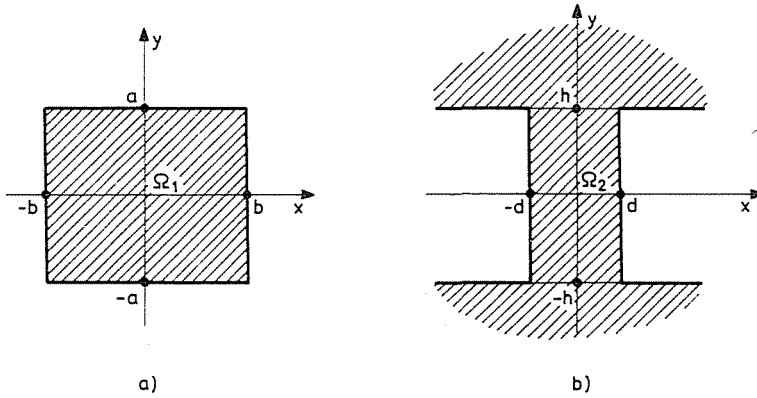

Fig. 3

The approximating functions have been constructed of Chebishev polynomials as

$$f_k(x, y) = T_{2i}(x/a) T_{2j}(y/b), \quad i, j = 0, 1, 2, \dots \quad k = 1, 2, \dots, n$$

where $T_i(\xi)$ denotes the i -th order Chebishev polinomial of the first kind with variable ξ .

The function $w_D(x, y)$ satisfying the condition (17) has been constructed with the aid of R -functions using [6], [7] as follows.

The planar region Ω shown in Fig. 2.b is formed by the section of the subregions Ω_1 and Ω_2 shown in Fig. 3.a and 3.b:

$$\Omega = \Omega_1 \cap \Omega_2.$$

The subregion Ω_1 is constructed as the section of the planar regions $\Omega_{11}(a^2 - y^2 \geq 0)$ and $\Omega_{12}(b^2 - x^2 \geq 0)$:

$$\Omega_1 = \Omega_{11} \cap \Omega_{12}$$

whereas the subregion Ω_2 is the union of the planar regions $\Omega_{21}(y^2 - h^2 \geq 0)$ and $\Omega_{22}(d^2 - x^2 \geq 0)$:

$$\Omega_2 = \Omega_{21} \cup \Omega_{22}.$$

The subregion Ω_1 is described by the R -function of the R -functions $w_{11} = a^2 - y^2$ corresponding to Ω_{11} and $w_{12} = b^2 - x^2$ corresponding to Ω_{12} :

$$w_1 = w_{11} \wedge w_{12}.$$

The subregion Ω_2 is given by the R -disjunction of the R -functions $w_{21} = y^2 - h^2$ corresponding to Ω_{21} and $w_{22} = d^2 - x^2$ corresponding to Ω_{22} :

$$w_2 = w_{21} \vee w_{22}.$$

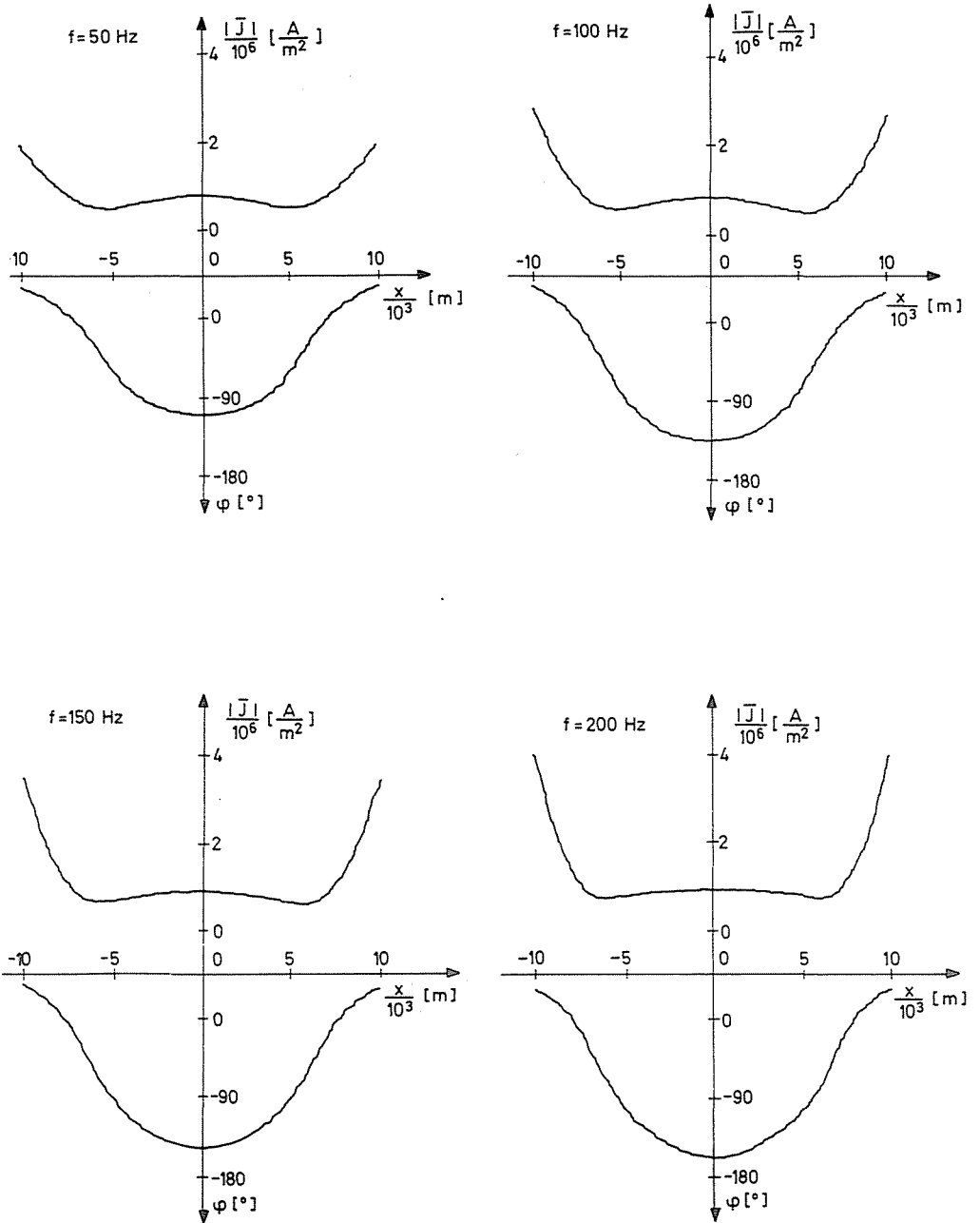

Fig. 4. Distribution of the amplitude and phase of current density along the x axis

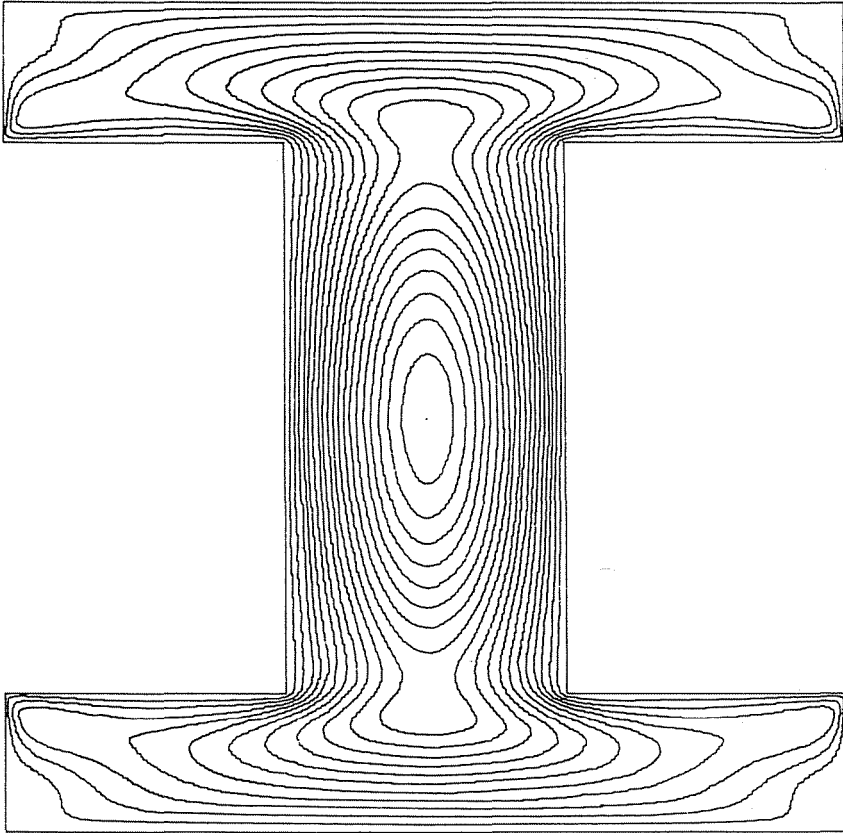

Fig. 5.a. Flux lines at $f=0$ Hz

The function $w_D(x, y)$ satisfying the condition (17) is, in accordance with the expressions of w_1 and w_2 :

$$w_D = w_1 \wedge w_2 = (w_{11} \wedge w_{12}) \wedge (w_{21} \vee w_{22}).$$

In the course of the analysis, an approximation of order $n=9$ has been employed.

In the knowledge of the vector potential, the distribution of the current density in the conductor can be given. In Fig. 4, the current density at $y=0$ has been plotted against the coordinate x at frequencies $f=50, 100, 150$ and 200 Hz. The variation of the amplitude and phase of current density has been plotted separately. The skin effect is easily recognized in the diagrams.

In Fig. 5, the flux distribution in the conductor has been plotted at frequencies $f=0, 50, 100, 150$ and 200 Hz. The flux lines in Figs 5.a–5.e have

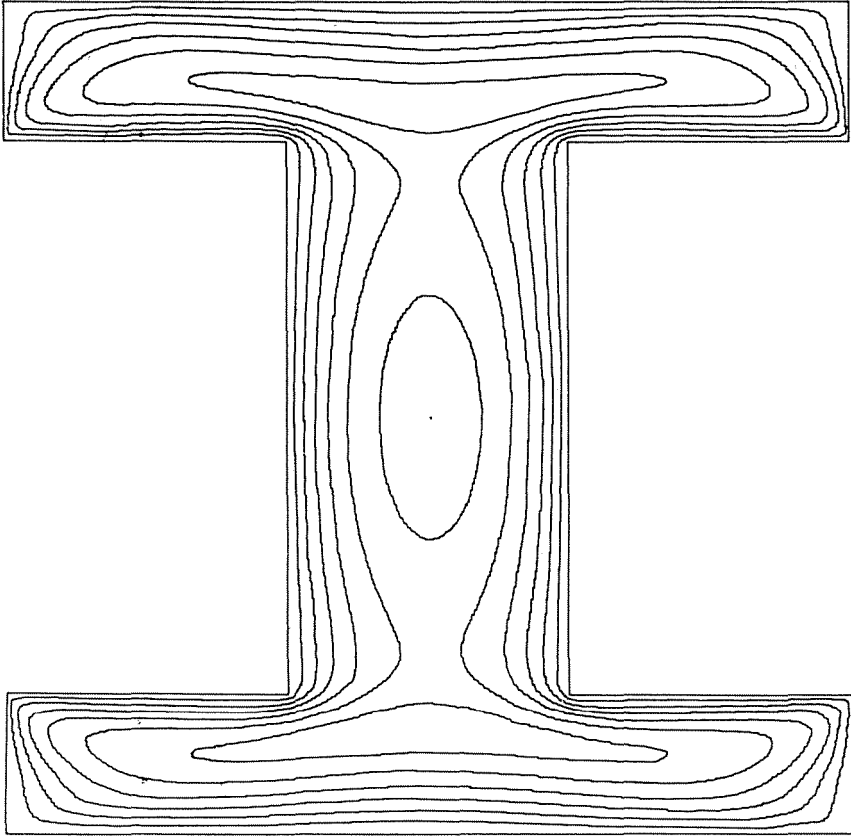

Fig. 5.b. Flux lines at $f = 50$ Hz

been selected so that the magnetic flux between any two lines of force is equal in each case. Therefore, fewer flux lines have been drawn at higher frequencies indicating the decrease of the intensity of the magnetic field with increasing frequency.

In the knowledge of the quasi-stationary field in the conductor, the impedance of a unit length of the conductor has also been determined. The resistance of unit length has been computed from Joule-loss as

$$R = \frac{1}{|I_0|^2} \int_{\Omega} \frac{|\mathbf{J}|^2}{\sigma} d\Omega,$$

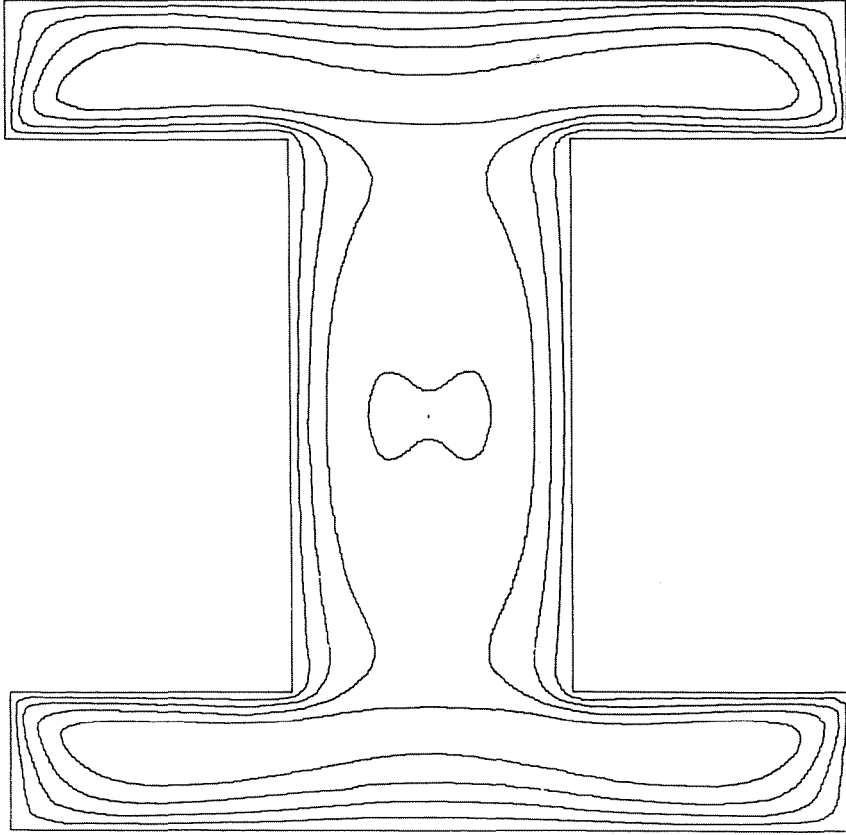

Fig. 5.c. Flux lines at $f = 100$ Hz

and the internal inductance from magnetic energy [1] as

$$L_i = \frac{1}{|I_0|^2} \int_{\Omega} \mu |\mathbf{H}|^2 d\Omega.$$

The values of the resistance and internal inductance at the frequencies examined are shown in Table 1. The ratio d/δ at each frequency has also been indicated in the Table 1, where $\delta = \sqrt{2/\mu\omega\sigma}$ is the skin depth. The ratios of the resistance and internal reactance against the D. C. resistance have been plotted in Fig. 6 as functions of frequency.

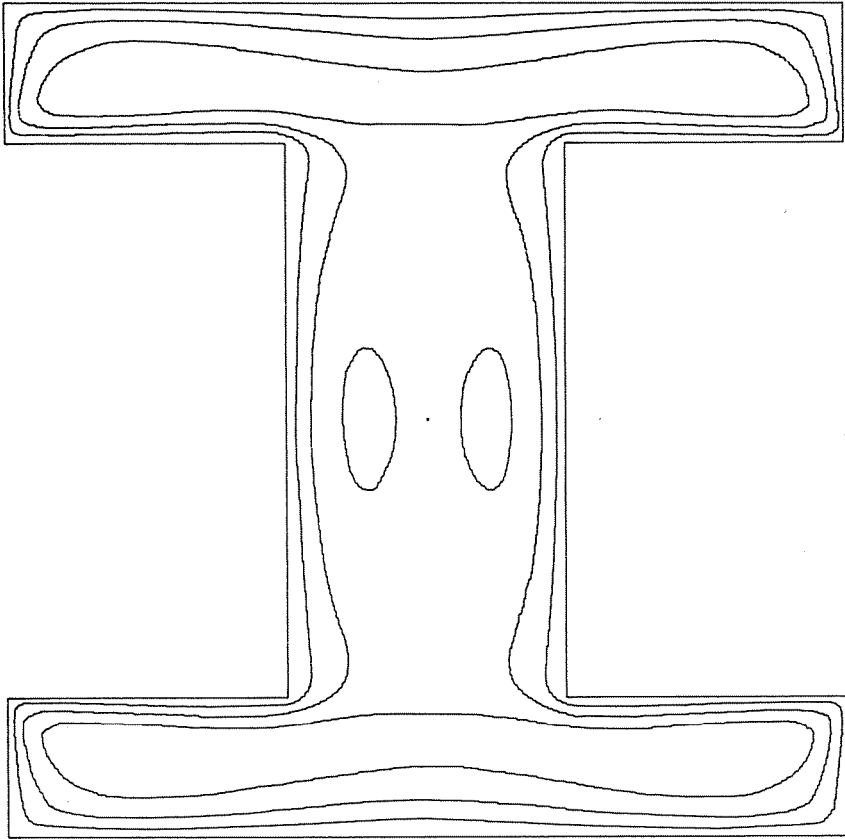

Fig. 5.d. Flux lines at $f = 150$ Hz

To check the results, it has been assumed on the basis of the flux plot that at frequency $f = 200$ Hz only the belts carry current. In this case, the ratio of the D. C. resistances of a ring of depth δ of the belts and of the entire conductor is $R_\delta/R_0 = 3,38$. This assumption is quite correct at the frequency in question [1], but is bound yield a higher value of the resistance due to the lower equivalent cross section taken into account. Hence, the value $R/R_0 = 3,25$ appearing in Table 1 seems to be a reasonable approximation.

The analysis has been carried out on a desk computer EMG 666. The diagrams have been drawn with the aid of a plotter NE 2000.666 connected to the computer.

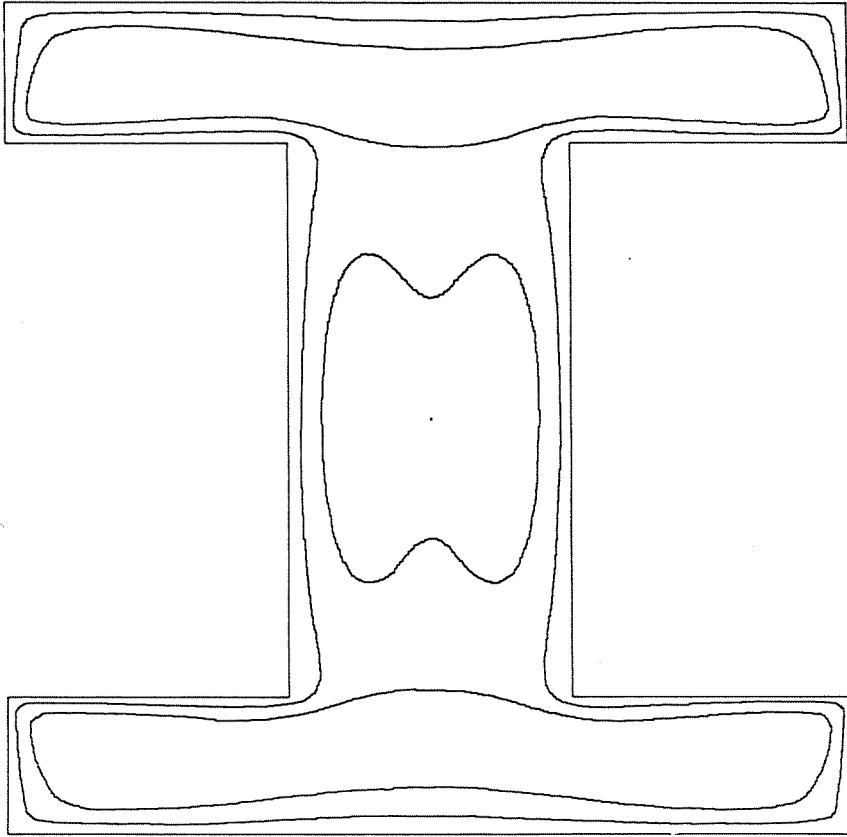

Fig. 5.e. Flux lines at $f = 200$ Hz

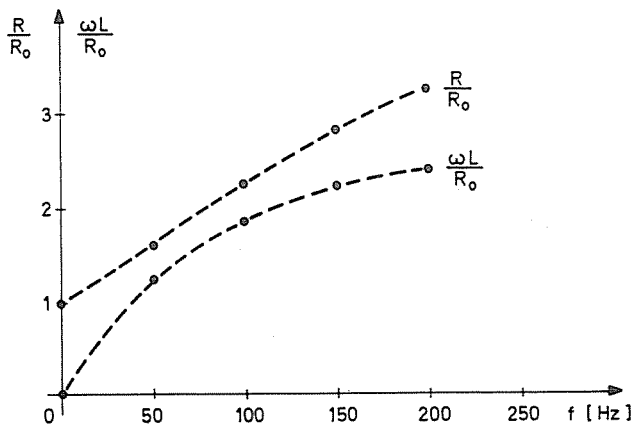

Fig. 6

Table 1

f (Hz)	R (Ω/m)	ωL_i (Ω/m)	R/R_0	$\omega L_j/R_0$	d/δ
0	$0.8 \cdot 10^{-4}$	0	1.00	0	0
50	$1.2963 \cdot 10^{-4}$	$9.9879 \cdot 10^{-5}$	1.62	1.25	2.22
100	$1.8100 \cdot 10^{-4}$	$1.4932 \cdot 10^{-4}$	2.26	1.86	3.14
150	$2.2815 \cdot 10^{-4}$	$1.7860 \cdot 10^{-4}$	2.85	2.23	3.84
200	$2.6005 \cdot 10^{-4}$	$1.9349 \cdot 10^{-4}$	3.25	2.42	4.44

References

- VÁGÓ, I.: Electromagnetic Theory. Tankönyvkiadó, Budapest, 1980. (in Hungarian)
- FODOR, GY., VÁGÓ, I.: Electrotechniques, book 12, Static and stationary fields. Tankönyvkiadó, Budapest, 1975. (in Hungarian)
- MIKLIN, S. G.: Variational methods in mathematical physics. Izd. Nauka, Moscow, 1970. (in Russian)
- MIKLIN, S. G.: Numerical realization of variational methods. Izd. Nauka, Moscow, 1966. (in Russian)
- KANTOROVICH, L. V.—KRYLOV, V. J.: Approximate methods of higher analysis. Akadémiai Kiadó, Budapest, 1953. (in Hungarian)
- RVACHEV, V. L.: Theoretical presentation of logical algebra. Izd. Technika, Kiev, 1967. (in Russian)
- RVACHEV, V. L.: The methods of logical algebra in mathematical physics. Izd. Naukova Dumka, Kiev, 1974. (in Russian)
- BÁRDI, I.: Numerical calculation of quasi-stationary electromagnetic fields by variational method. Theses for the degree of Cand. Sc., Hungarian Academy of Sciences, 1981. (in Hungarian)
- BÁRDI, I.: Electromagnetic field of coupled conductors by variational calculus. Periodica Polytechnica, Electrical Engineering, 25. 249. (1981.)
- TSIBOUKIS, T. D.—KRIEZIS, E. E.: Calculation of inductance of conductors with various shapes of cross section by direct method of the functional analysis, (to appear)
- TOZONI, O. V.: The method of secondary sources in the electrotechniques. Izd. Energia, Moscow, 1975. (in Russian)
- TOZONI, O. V.: Computation of electromagnetic fields on computers. Izd. Tekhnika, Kiev, 1967. (in Russian)
- IVÁNYI, A.: Determination of static and stationary electromagnetic fields by using variation calculus. Periodica Polytechnica, Electrical Engineering, 23. 201 (1979).
- IVÁNYI, A.: Application of variational calculus to the solution of two-dimensional problems of static and stationary electromagnetic fields. Theses for the degree of dr. techn. Technical University of Budapest, 1980. (in Hungarian)

Dr Amália IVÁNYI H-1521 Budapest