

CONTINUOUS IMAGE-FORMING SYSTEMS OF LARGE FIELD OF VISION (TELESCOPES)

N. BÁRÁNY

Institute for Instrumental Design and Precision Mechanics, Polytechnic University,
Budapest

(Received May 30, 1957)

I

It is not the aim of the present paper to give a detailed specification of telescopes. Our investigations are chiefly concerned with the geometrical relations of the *field of vision*. The field of vision of the telescope is in close correlation with magnification which, according to Fig. 1, is the quotient of the focal length f for the objective, and f_1 for the eye-piece, or

$$N = f : f_1 .$$

If the telescope is adjusted to infinity, the image lies in the focal plane of the objective. The angle included between the lines connecting points A and C of the image with the centre O of the objective is the *real* field of vision viewed through the eye-piece 3 at an angle α_1 representing the *virtual* field of vision. The quotient of the virtual and real fields being also equal to the magnification of the telescope

$$N = \alpha_1 : \alpha .$$

In addition to the focal length of the objective, the real field of vision is determined by the virtual field. Both theoretical and practical considerations induce us to limit the virtual field of vision at 75° . For various reasons, a further increase would be inexpedient. Unlike photolenses, even wide-range telescopes can only cover a limited portion of the object space at one time, in correspondence of geometrical laws. For covering further portions of the object space, one has to turn the head, together with the telescope. The real field of vision for conventional trench telescopes, for example of a magnification of 6 is 7° , covering a field of 140 m diameter at a 1000 m distance. In the case of telescopes of lesser magnification — opera glasses — the covered field is not more than 15° which is still very unsatisfactory in relation to the full 360° field.

The basic idea of simultaneously covering the entire 360° field was first established by MANGIN¹ (Fig. 2).

¹ MANGIN, Association française pour l'avancement des sciences 7, Paris 339, 1878.

According to Mangin's theory, the arc BC of a circle of Radius R , if rotated about axis O describes a toroidal surface, reflecting the beams L incident, perpendicularly to the axis O , from all directions of the field. The image thus formed by the concave mirror ring is a real, that is, a receivable annular (pano-

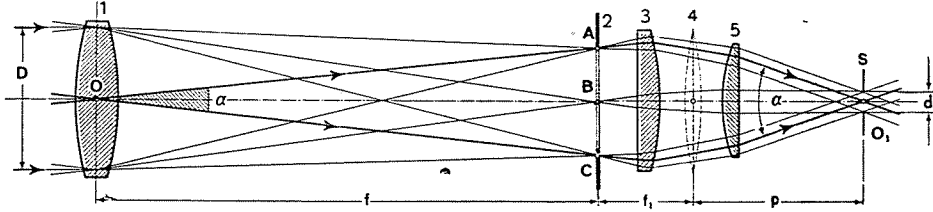

Fig. 1. Determination of the field of vision by means of a simple inverting telescope. Relationship between real and virtual field of vision. The eye-piece consisting of the condensing (field) lens 3 and the eye lens 5 is represented by the resultant lens 4 with a focal distance f_1

ramic) image. Such a device however, cannot justly be considered a panoramic system, since the telescope will only form annular images of objects situated at small angles.

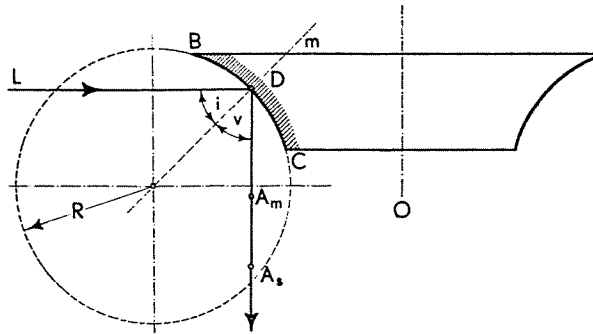

Fig. 2. Creation of the Mangin toric surfaces. Tangential and sagittal image points

The image of a distant point formed by tangential pencils is at A_m , while that formed by sagittal pencils is at A_s . According to the rule of astigmatic image formation

$$CA_m = \frac{R \cdot \cos i}{2}$$

and

$$CA_s = \frac{R_1}{2 \cos i}$$

for the sagittal pencils, m representing the normal of incidence, i the angle of incidence and v the angle of reflection. R_1 is the second radius of curvature

obtained by rotation in the sagittal section of the toroidal surface. The condition for correcting astigmatism is that

$$CA_m = CA_s$$

Hence it follows that

$$\frac{R}{R_1} = \frac{1}{\cos i^2}.$$

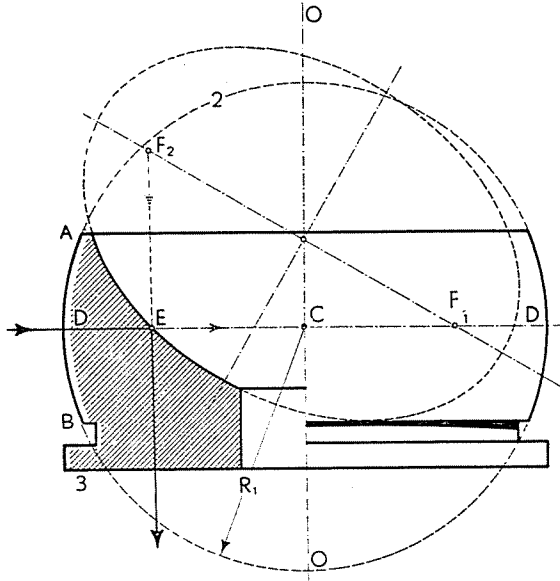

Fig. 3. Lens producing a panoramic image. The surface of incidence is spherical, while the reflecting surface is an ellipsoid and the surface of emergence is plane

Thus, if freedom from astigmatism is obtained by means of such a surface, a certain amount of spherical aberration and deviation from the sine condition must be taken into account. Furthermore, it is impossible to achieve complete freedom from distortion.

Systems forming panoramic images have been designed by using various surfaces of rotation of higher order, and this is how the various kinds of annular lenses were produced. The annular lens represented in Fig. 3 have a spherical entry surface 1 of radius R_1 , while the reflecting surface is an ellipsoid. The spherical zone AB is so situated that its diameter D intersects one of the foci F_1 of the ellipsoid. In order to produce images, the emerging pencils have to be directed to a lens or lens arrangement placed under the annular lens. The horizontal pencil incident upon the spherical zone AB intersects the centre C of the sphere. The ellipsoid 2 is so situated, that the pencil be reflected at point

E as if coming from the other focus F_2 of the ellipsoid. The axis of rotation O intersects the centre C of the sphere and bisects the transverse axis of the ellipsoid. The plane surface 3 is perpendicular to the emerging pencil in order to

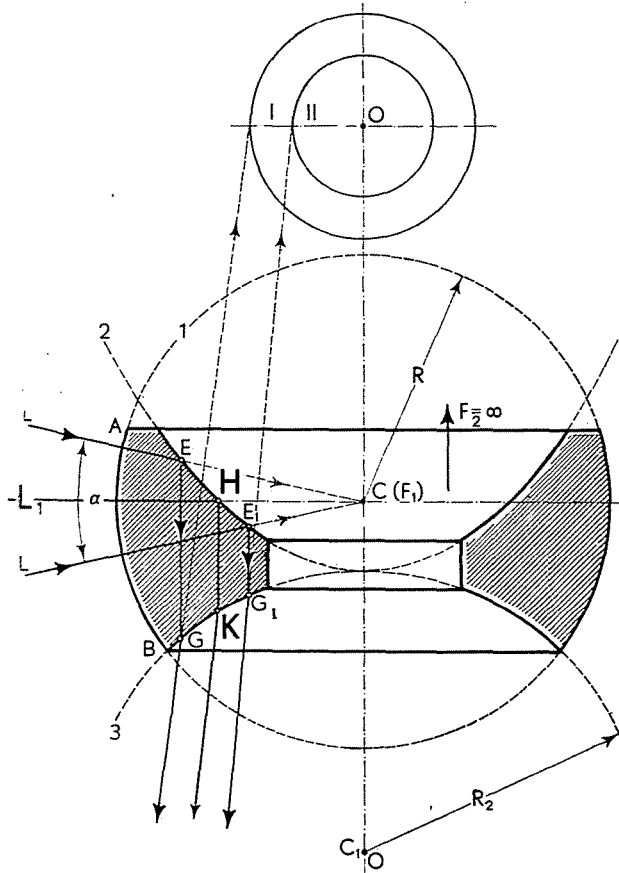

Fig. 4. A lens producing a panoramic image. The surfaces of incidence and emergence are spherical, while the reflecting surface is a paraboloid

ensure its unrefracted emergence. The role of the aperture in the centre of the annular lens will later on be discussed.

Another embodiment of the system is shown in Fig. 4 where the centre C of sphere 1 (radius = R_1) is coincident with the focus F_1 of the parabola 2. The pencil of rays from L_1 , incident upon the spherical zone AB points towards the centre C , and is reflected at point H of the parabola parallelly to the rotation centre O , as if originating from the other focus F_2 situated at infinity. The pencils travelling from the direction $L-L$ towards C , and subtending an angle α , are reflected at points E and E_1 of the parabola, whereupon they emerge refracted

at points G and G_1 of the spherical surface 3 traced by rotating the radius R_2 about point C_1 . The locus of the virtual image is above the lens. Part I of the panoramic picture represents the sky whereas part II shows the field.

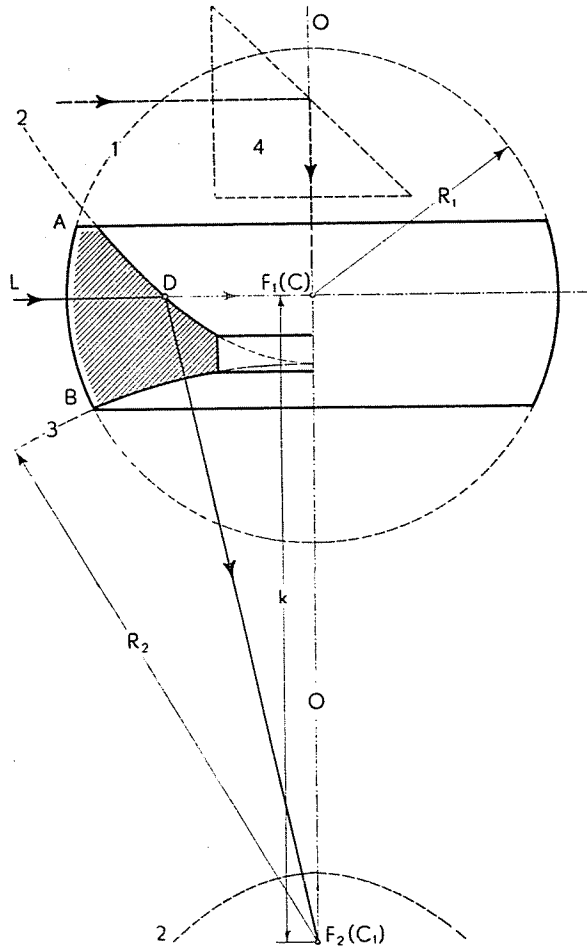

Fig. 5. A lens producing a panoramic image. The surfaces of incidence and emergence are spherical, while the reflecting surface is a hyperboloid

The diagram in Fig. 5 illustrates a system with spheres of radii R_1 and R_2 respectively, as surfaces of incidence of emergence, and with a hyperboloidic surface of reflection. The virtual foci F_1 and F_2 are so situated that the ray reflected at point D of the spherical zone AB intersects the optical axis O , corresponding to the axis of rotation, at the other focus F_2 . For purposes of easier illustration of the distortions of the image formed by the annular lens a rather short distance k was chosen, and the cross-shaped areas 4 to 8 and III to VII of the cross-ruled network in Fig. 6 have been hatched.

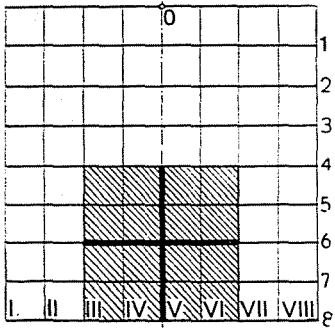

Fig. 6. Cross-ruled network for illustrating the distortions associated with panoramic image formation

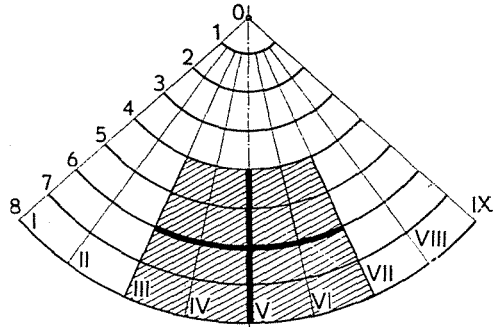

Fig. 7. Distorted image of the network represented in Fig. 6, produced by an annular lens

Fig. 7 shows the image of this network produced by the annular lens. The straight lines 1 to 8 are distorted into arcs around the centre O. Magnification changes radially, but remains constant for the points connected by the arc. Evidently, tangential magnification is also impaired. The centre of projection is at O, thus distorted image satisfies the rules of central projection.

The annular image varies with the type of optical arrangement employed, but the construction of the image closely follows the laws of central projection. In the variations shown in Fig. 8 and 9 the image is viewed at the outer margin of the field of view, and at the inner margin respectively. Thus, their direction is opposed in relation to each other.

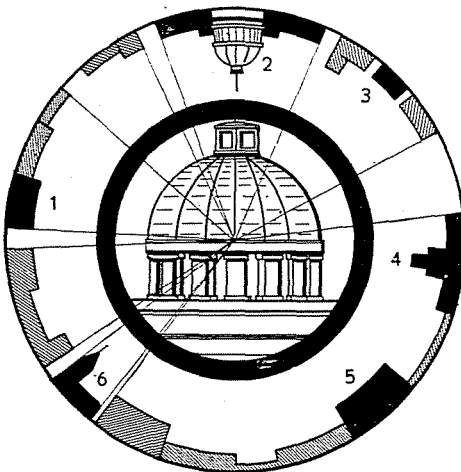

Fig. 8. Panoramic image formed along the outer margin of the field of vision. The centre of projecting lies in the centre of the field of vision

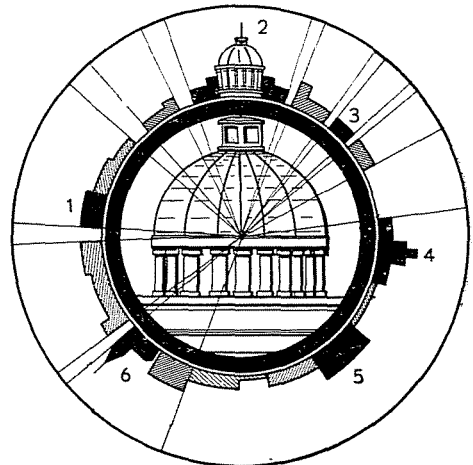

Fig. 9. Panoramic image formed about the inner margin of the field of vision. In both Figures the magnified image of the sighted object in the inner field of vision is produced by pencils of rays directed by another system and passing through the aperture of the annular lens

Ring lenses had to be further improved in order to satisfy the strategic requirements, arising in connection with periscopes, these latter being important equipments of submarines. Periscopes are supposed to enable the personnel to obtain a full view of the entire surface of the sea. The inner part of the annular



Fig. 10. Panoramic image with the inner part magnified, produced by a Goertz periscope image, with a magnification of 0,4 to 0,6, presents images of the sighted point or the field respectively, enlarged by a factor 6 (Fig. 10).

In 1950 a Hungarian physicist, PÁL BOTTKA succeeded in designing a lens system representing an annular mirror lens (Fig. 11), as an amalgamation of the Hill lens with the annular lens. The Bottka lens covers an angular field of 200° , and provides satisfactory image formation. After reflection, the rays

incident on the front lens arrive to the reflecting surface II of the back lens. Then, after being reflected by the reflecting surface of the front lens, they emerge from the system parallel with the optical axis. The telescopic image is yielded by a lens arrangement mounted behind the mirror lens.

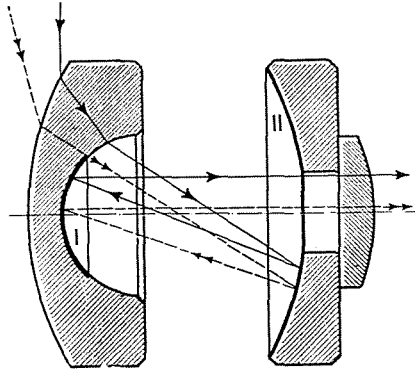

Fig. 11. Panoramic mirror lens arrangement by Pál Bottka

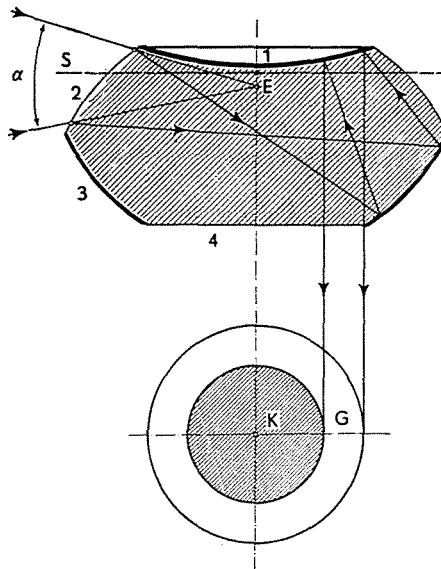

Fig. 12. One-component panoramic lens by Sándor Majoros, comprising both spherical and plane surfaces

Another Hungarian development is an annular lens designed in 1951 by the Hungarian engineer S. MAJOROS. Fig. 12 presents the one-component lens, solely bounded by spherical surfaces. The annular image *G* is generated in front of the lens.

It is possible to direct pencils of rays emerging from optical systems of varying magnification power through the central opening of the annular lenses.

In the case of the Majoros lens the central image k is produced by the prism and lens arrangements mounted under the lens. The parallel pencils emerging from the lens can, of course, only form images if a system for rendering the pencils convergent is set up behind the lens, as represented in Fig. 13. The lens of diameter D has metal-coated reflective surfaces 2 and 5. The pencils 1 enter the system from all directions under 32° angles and are refracted once, and reflected twice, thus forming an annular path of rays 3 when emerging. The lens arrangement 4 — a triplet in our example — inserted behind the lens form images with the rays at a certain distance.

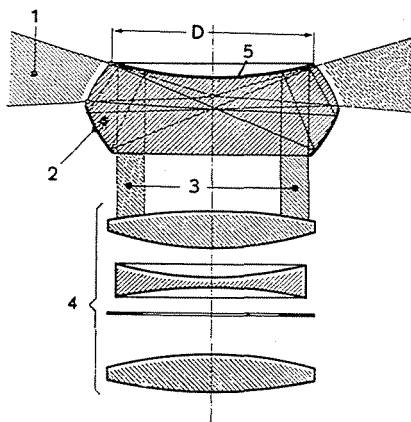

Fig. 13. The path of rays in the Majoros annular lens, together with the positive three-component lens arrangement 4 placed behind the lens

The ring lenses composed of surfaces of rotation of higher order are liable to be easily damaged, they are costly, and in some cases can be produced only in large sizes. Moreover, the annular image is afflicted with heavy distortion, and the maximum enlargement is $\times 0.9$. These drawbacks have so limited the usefulness of annular lenses, that the older types are now practically obsolete. With a view to consistency and uniformity, it was nevertheless deemed advisable to give a survey of these lenses, particularly since most of these systems involve ingenious and unexpected solutions.

The so-called multiperiscopes enable representation of the horizon in sections, — if not as a coherent panoramic view. A panoramic picture composed of uniform sections is produced by a number of periscopes pointing in various directions. This solution has the advantage of yielding undistorted, images covering fields of mean size, even for higher magnifying powers, and permitting the simultaneous presence of several observers. Nevertheless, this arrangement proved unsatisfactory owing to its large dimensions.

The periscope was designed with a view to produce a smaller instrument, still admitting several observers. Here, the images are formed by several independent telescopes having one common objective.

P. TRIULZI's 1942 patent relates to a multiperiscope. This instrument comprises eight symmetrically arranged panoramic prismatic telescopes and a central air reconnaissance telescope, all of them mounted in a common tube.

Multiperiscopes are rigidly fixed and cannot be rotated about their vertical shaft, whereas simple periscopes are rotated by the observer around the vertical shaft, under constant changes of position, in order to achieve full coverage of the horizon. Another type provides a reflector prism bedded in the upper part of the periscope by whose rotation the succeeding zones of the horizon can be scanned. The first solution is simpler, the second one more

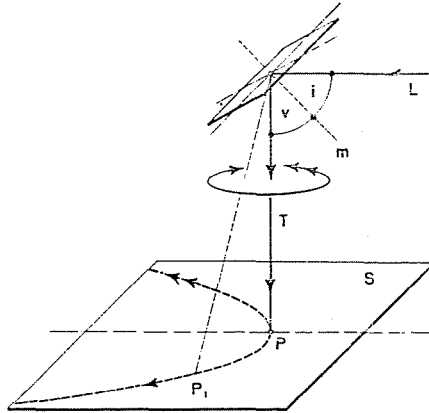

Fig. 14. A plane mirror making a 45° angle with the incident ray, rotated about an axis normal to the optical axis. The trace of the reflected ray describes a curve of fourth degree

convenient. On swinging the reflector prism, the image is laterally displaced in the field, and at the same time suffers tumbling of the image so that observation is almost impossible. It is therefore necessary to provide another optical system with a view to correct image tumbling arising in connection with the lateral displacement.

Before proceeding to the description of the equipment to be applied in optical systems, let us make an investigation into what happens if a mirror or prism subtending an angle with a ray is rotated about the axis perpendicular to the incident ray. Let us determine the curve described by the trace of the reflected ray on the basic plane (Fig. 14).

The plane mirror L makes a 45° angle with the horizontally incident ray L . The ray reflected under an angle v reaches the plane S at P . On swinging the mirror about the reflected ray T as axis, point P will describe the curve indicated by the arrows, in the sense of rotation. The mirror situated at O (Fig. 15) subtends a 45° angle with the vertical. Its normal, rotated about the vertical axis, describes a conical surface of an angular aperture of 45° . Let the normal be situated at say, $O'N$, let the ray directed to S have a surface of incidence $SO'N$,

let the angle of incidence be φ let the direction of the reflected ray be $O'P$, and, finally, let the angle of reflection be $NO P = SO'N = \varphi$. Let the angle included between the surface of incidence and the perpendicular surface $SO'O$ be α . On swinging the mirror, its normal will travel from $O'N'$ to ON' , while the value of α will simultaneously change from 0 to 45° . Let us determine the relation between the coordinates x and y of point P with the angle α .

The first relation to be determined is that between the angles φ and α . Let the radius of the sphere represented in the figure be $R = 1$. In this case,

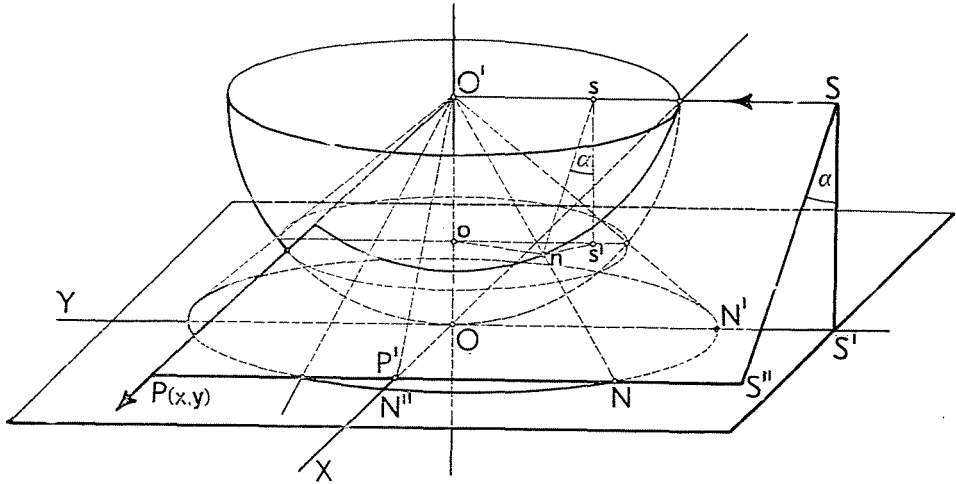

Fig. 15. Geometrical analysis of the ray reflected by the plane mirror represented in Fig. 14

from the triangles nss' and $O'ns$

$$ns = \sin \varphi, \quad ss' = ns \cdot \cos \alpha = \sin \varphi \cdot \cos \alpha$$

since

$$O'_0 = O'n \cdot \cos 45^\circ$$

$$s s' = O'_0,$$

$$s s' = \sin \varphi \cdot \cos \alpha = \frac{1}{\sqrt{2}}$$

whence

$$\sin \varphi = \frac{1}{\sqrt{2} \cos \alpha}. \tag{1}$$

Let us now determine the dependence of $y = PP'$ from φ , that is, from α . In the triangle $PO'P$

$$PO'P' = 2\varphi - \frac{\pi}{2}$$

therefore

$$y = O'P' \operatorname{tg} \left[2\varphi - \frac{\pi}{2} \right] = -O'P' \operatorname{cotg} 2\varphi. \quad (2)$$

The angle at O' in the triangle $OO'P'$ is a , thus

$$O'P' = \frac{OO'}{\cos a} = \frac{1}{\cos a}$$

$$y = -\frac{\operatorname{cotg} 2\varphi}{\cos a}. \quad (3)$$

The $\operatorname{cotg} 2\varphi$ in formula (2) is expressed by angle a . For this end not only formula 1. is needed, but the expression of $\cos \varphi$ by a , too. Using formula (1)

$$\cos \varphi = \sqrt{\frac{2 \cos^2 a - 1}{2 \cos^2 a}} \quad (4)$$

$$\cos 2\varphi = \frac{\cos^2 a - 1}{\cos^2 a} \quad (5)$$

$$\sin 2\varphi = \frac{\sqrt{2 \cos^2 a - 1}}{\cos^2 a} \quad (6)$$

From formula (5) and (6)

$$-\operatorname{cotg} 2\varphi = \frac{1 - \cos^2 a}{\sqrt{2 \cos^2 a - 1}}. \quad (7)$$

Applying formula (7) in formula (3)

$$y = \frac{\sin a \cdot \operatorname{tg} a}{\sqrt{2 \cos^2 a - 1}}. \quad (8)$$

Let us now examine the dependence of coordinate x of point P from the angle a . In the triangle $OO'P'$ $OP' = x$ and $OO' = 1$. The angle situated at O' is a , whence simply

$$x = \operatorname{tg} a \dots \quad (9)$$

The equations (8) and (9) produce the parametric set of equations of the curve described by point P . Now eliminating the angle a , $\operatorname{tg} a$, $\sin a$ and $\cos a$ may

be expressed by x , hence $\operatorname{tg} a = x$

From the relation

$$1 + x^2 = \frac{1}{1 - \sin^2 a} \quad (10)$$

thus

$$\cos^2 a = \frac{1}{1 + x^2} \quad (11)$$

From the same

$$1 - \sin^2 a = \frac{1}{1 + x^2} \quad (12)$$

that is

$$\sin^2 a = 1 - \frac{1}{1 + x^2} = \frac{x^2}{1 + x^2} \quad (13)$$

From equation (8):

$$y^2 = \frac{\sin^2 a \cdot \operatorname{tg}^2 a}{2 \cos^2 a - 1} \quad (14)$$

Applying the equations (11) and (13):

$$y^2 = \frac{\frac{x^2}{1 + x^2} x^2}{2 - \frac{1}{1 + x^2} - 1} = \frac{x^4}{2 - 1 - x^2} = \frac{x^4}{1 - x^2} \quad (15)$$

Thus, the ray reflected by the mirror describes the curve of fourth degree

$$y = \frac{x^4}{1 - x^2}$$

on the plane at unity distance from the mirror and perpendicular to the axis of rotation of the mirror.

Similar phenomena are experienced on rotating a right-angled 45° prism replacing the plane mirror 1 in Fig. 14. Moreover, the angle of deviation of the reflected ray is twice the angle by which the prism is turned. In the visual field of such telescopes the image is not only laterally displaced but is also tumbling, though not along the arc, but along the curve of fourth degree. The problem to be answered is, to combine the reflector prism with an optical arrangement which will laterally displace the image — upon rotation of the

reflector prism — without, however, causing the image to tumble. Such a prism, being able to keep the image erect, in the course of its lateral motion, is, therefore called *erecting prism*.

The first suggestion, as well as, the first practical realization of the erecting prism is due to Chief Engineer Jacob, scientific advisor of the former C. P. Goertz company, in 1905, and has since been in use throughout the world, without any material changes in design.²

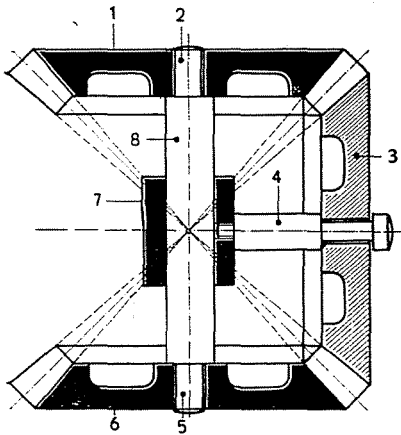

Fig. 16. The general principle of a differential gear

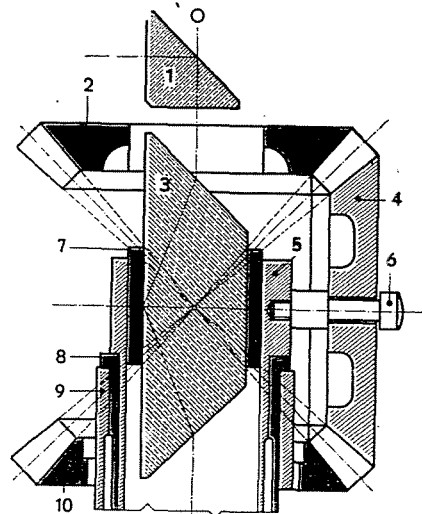

Fig 17. The Dowe erecting prism controlled by differential gear

These so-called panoramic telescopes allow the observer to sweep the successive sections of the horizon without having to turn the head, by swinging the reflector prism fitted into the top of the instrument. The real field of vision of the telescopes is of 10 to 14°, and the horizon may be observed in the form of a continuous band picture extending over the entire field. In order to obviate tumbling of the image, the right-angled 45° reflector prism rotatable about the vertical optical axis, is so connected with the Dowe erecting prism, that this latter follows the reflector prism with identical sense of rotation, but with half the rotary speed. To fulfill this condition one may introduce a differential gear, too commonly known to be described at all. Nevertheless, it seems advisable to describe its action, as the differential arrangement for telescopes, having two gears less than usual, is somewhat different in construction from conventional differential gears used for motor vehicles.

² K. PRITSCHOW, Das Rundblickfernrohr. Ztschft. f. Feinmechanik 2, 1915, XIII. 9.

The differential gear represented in Fig. 16 has bevel gears 1 and 6, loosely set on the pins 2 and 5 of shaft 8. They are connected by the bevel gear 3 mounted, free to turn, on the shaft 4 fixed into sleeve 7, freely rotating round the shaft 8. Let us suppose that bevel gear 6 is at a standstill, and the gear 1 is rotated around pin 2. The planet gear 3 connected with gear 1 will also rotate and, revolving along the stationary gear 6, will also take along shaft 4. If the bevel gears 1 and 6 are rotated in opposed direction but with identical rotary speed, planet gear 3 will revolve, while remaining in place, around shaft 4.

Its application for telescopes is represented in Fig. 17. Let prism 1 rotate together with gear 2, this latter will take along planet gear 4, which in turn,

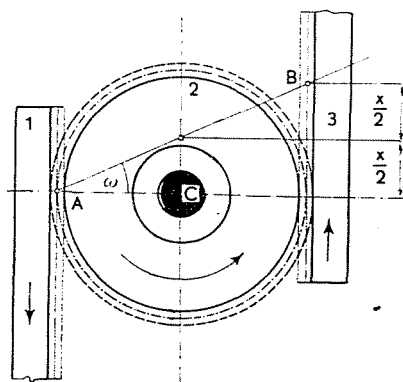

Fig. 18. Relationship between the gears of a differential arrangement

revolving along the stationary gear 10 will turn the Dove prism 3 by means of shaft 6 with a transmission ratio 1 : 2. Prism 3 with its mount 7 is bedded in sleeve 5 which can revolve in the bearing 8 fitted into the telescope tube 9. If the bevel gears 2 and 10, being fixed to the top and to the bottom of the telescope, respectively, are turned in opposed sense, but with an identical angle, planet gear 4, shaft 6 and prism 3 remain stationary.

The diameter of the planet gear can be chosen at will, but the diameter and the cog number must be identical for the two driving gears. Fig. 18 shows an arrangement where the bevel gears have been substituted by the ratchets 1 and 3. In case of a displacement in opposed direction but of identical magnitude, shaft C of planet gear 2 is independently displaced from the diameter of the planet gear with half the rotary speed ($\omega : 2$).

Fig. 19 represents the Wild panoramic telescope with differential gear and refracted magnifier.

For the vertical adjustment of the reflector prism a separate driving mechanism is provided, to be operated by means of a knob, to be seen on the top right-hand side in Fig. 19. Thus, lateral and vertical adjustment have

to be carried out in two separate steps requiring both hands for simultaneous adjustment. There are, however, cases when simultaneous but independent adjustment is imperative.

The telescopes of mechanical construction present ingenious combinations of constructional and optical ideas.

The instrument represented in Fig. 20 designed by the Hungarian engineer NÁNDOR LIPPERT who died at an early age, is a combination of multiperiscopes

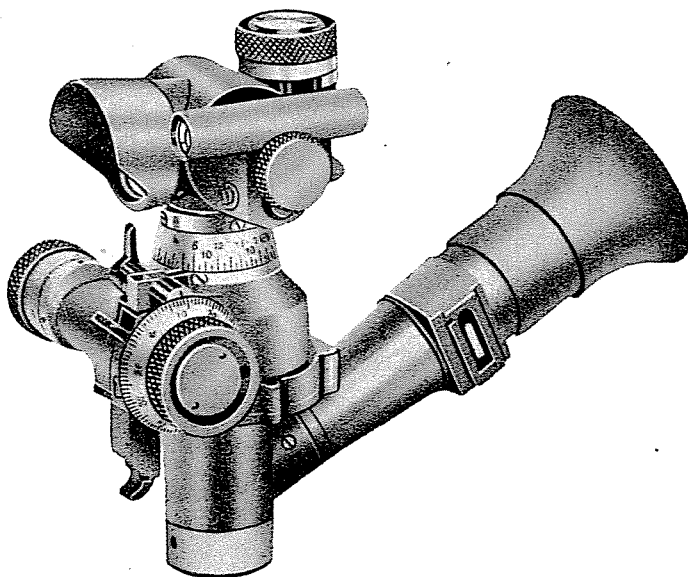

Fig. 19. The Dove prism rotated by a differential gear, applied in the Wild sighting telescope of refracted sight line

and of annular image-formation. This instrument is noteworthy from the point of view of optomechanics, even though it has not found wide popularity, owing to its disadvantages described below.

Just as for multiperiscopes, the panoramic image is cut up into sections, with the magnified image of the section just sighted, situated in the centre. On rotating the reflector prism, the central image is shifted, as has been described in connection with panoramic telescopes. The main difference against multiperiscopes is that the images produced by the individual telescopes appear simultaneously in the field of vision, together with the central image. Sighting is done by means of the central image, observation by the panoramic images. The central sighting telescope is surrounded at equal angular distance by eleven telescopes forming image sections. The tumbling of the image occurring in connection with the turning of the reflector prism 1 of the sighting telescope, is corrected by the erecting prism 2. The image formed by means of the objective

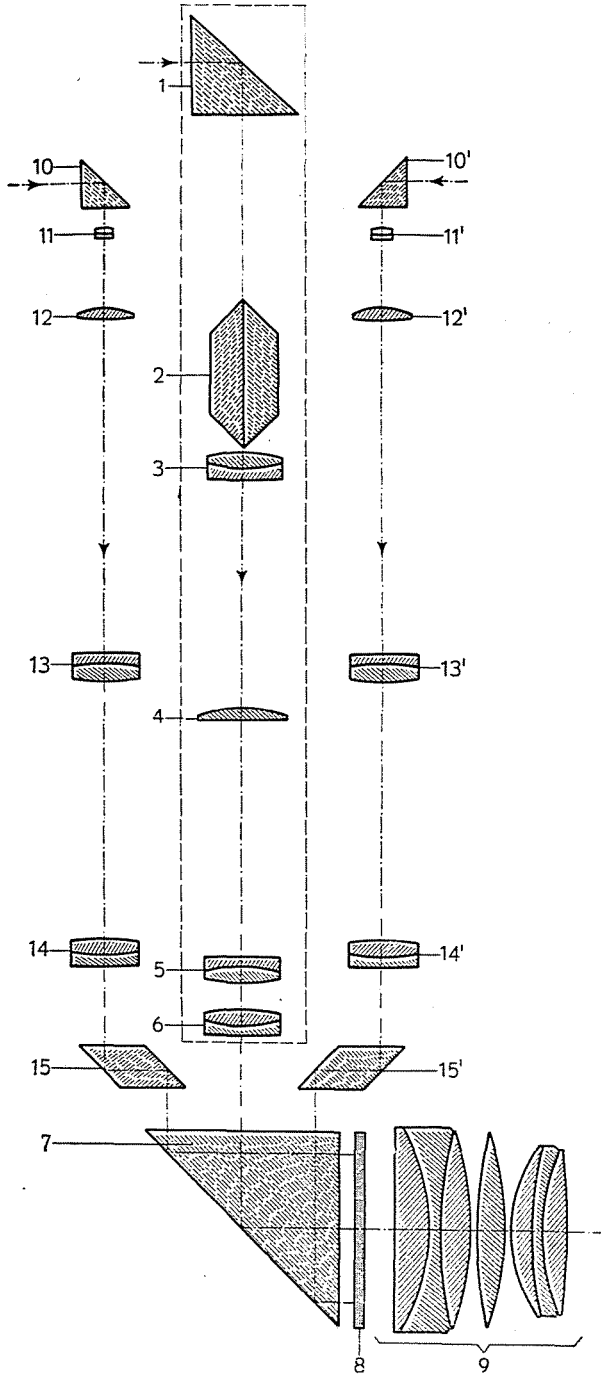

Fig. 20. Multiperiscope by Nándor Lippert, with dual field of vision

3 appears on the plane surface of the lateral field lens 4 of the objective. The inverting system consisting of lenses 5 and 6 form a second image through prism 7 on the cross-hair plate 8 which is observed through an eye-piece covering an unusually wide field. The apparent field of vision of this eye-piece, designed by the Hungarian engineer J. BARABÁS, is 90° . The optical arrangement of the individual telescopes are very similar to the instrument described above, but their magnifying power is lower. The images formed by the wide-angle objectives 11, 11' . . . of short focal length, situated under the rigidly fixed reflector prisms 10, 10' . . . arise in the vicinity of the field lenses 12, 12' The inverting systems consisting of lenses 13, 13' . . . and 14, 14' merge the

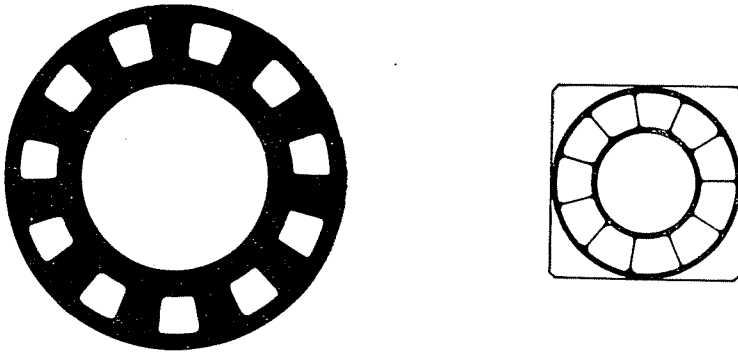

Fig. 21. The screens used in the multiperiscope shown in Fig. 20. The left-hand screen lies in the plane of the condenser lens at the objective side, whereas the right-hand screen is in the field of vision. The images are arranged in fan-shape, separated by thin gaps. The panoramic image obtained, although free from distortion, is incomplete, owing to overlapping at the bottom

section images over the rhombic prisms 15, 15' . . . and the common prism 7 into a fan-shaped panoramic image, visible on the cross hair plate 8. The whole instrument is stationary, except for the rotatable prism 1 of the sighting telescope. With its aid, the enlargement of the images formed by the individual telescopes can be brought to the centre of the field of vision.

The section images are separated by thin spokes or spaces, giving rise to the chief defect of the instrument consisting in that the panoramic image is not continuous and does not altogether satisfy the rules of central projection. The erect images are placed in line without overlapping, but they cannot be arranged in a circle, their continuity being broken on the top. On pushing the images nearer to one another, they will be overlapping below, while a wedge-shaped space will arise on top. An attempt to approach the top part of the images causes the bottom part to overlap to such an extent that serious losses arise. Continuity of the images is further impaired by the spokes or spaces of the screen inserted in the image plane. The section images generate in the

spaces left by the spoked screen situated in the vicinity of the field lens 12 (Fig. 21). The optical arrangement of the telescopes is such, that the images may be viewed in sections separated by thin spokes. However thin, the spokes are very inconvenient.

II

The principle of producing undistorted panoramic picture

The principle set forth below for projecting undistorted panoramic pictures or sections thereof, is based on an optico-psychological factor inherent to the human eye, that is, the effect of after-images, a widely, known phenomenon the main field of application which is motion-picture projection.

Motion picture projection consists of the successive and superposed projection of stills separated by short intervals where projection, with a frequency of 28 to 32 of the individual pictures displaced in phase, produces the sensation of continuous motion.

The underlying principle of function, of the instrument to be described below is similar, in so far as the stills are also projected with intervals but juxtaposed instead of superposed. The instrument may be so designed as to allow the projection of a complete panoramic picture or of parts thereof, requiring annular or wide projection screens. In the latter case, the projection screen has to be wider than the kind used for cinematoscopic projection. It should be noted, that projection is effected without the use of anamorphic lenses.

The principle governing the instrument is diagrammed in Fig. 22. On rotation of the reflector prism 1 about the optical axis $O-O$, the erecting prism 2 revolving in identical sense, but with half speed forms, in the image plane 5, images of each successive point of the horizon, by objective 3, over prism 4. Following the slow rotation of the prism, the image is continuously displaced in the visual field, with a sufficiently slow motion to allow observation of the adjacent sections of the horizon. If one takes photographs of the images, their assembly will yield a coherent panoramic picture of the object space. Incidentally, this can be effected as well by means of panoramic photocameras. For prisms of high revolution per minute, however, the image will be blurred past distinction. (Fig. 23). For periodic projection, the image formed in the focal plane of the objective 3 is periodically interrupted by the slits of a rotary sector disc 5 driven by motor 4 (Fig. 24). At the same time, the axle 6 and the spur gears 7 and 8 drive the reflector prism 1 as well as, by means of a non-represented transmission, the erecting prism 2. This latter is driven with half *R. P. M.* Each position of the prism is associated with a separate picture, but rapid rotation of the prism will give rise to a heavily blurred picture (Fig. 25).

The task set for undistorted panoramic image formation is to juxtapose the successive pictures, in conformity with field position, that is, by bringing into relief that section of visual field falling into the sighting line (Fig. 26).

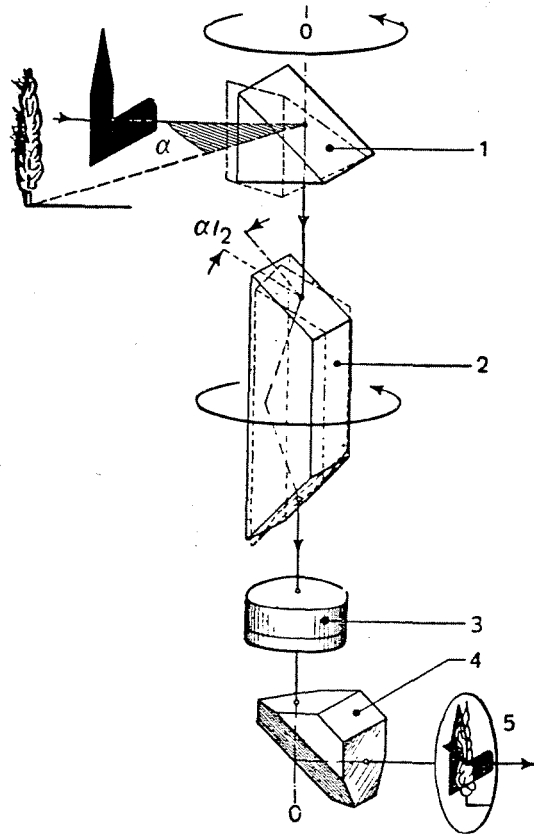

Fig. 22. Conditions arising through rotation of a right-angled 45° prism, in a telescope of refracted sight line

The instrument works in the following manner: the axle 13 of motor 14 drives the rotary sector disc 4, while the spur gears 15 and 16 drive the reflector prism 1. The drive of the erecting prism 2 is again not represented. The objective 3 produces a small-sized wide-angle image I in the plane of the slit of sector disc 4, situated within the focal range of lens 5. The emerging bundle travels parallelly over prism 6 to objective 7 which forms a second image from the first image over prism 8 at point II of the band image plane 9. The objective 7 always receives parallel bundles, so that this lens may be shifted, together with prism 8, into positions 7' and 8'. In the latter case the image is formed at II'. Mount 12 comprising objective and prism is so directed by the motor-driven



Fig. 23. Image formation by an arrangement diagrammed in Fig. 22, showing the landscape in Fig. 24

heart-cam 11 by means of the arm 10 that the mount will stop the end positions A and A' , whereas it covers the distance X to and from at a uniform speed.

There is only one slit of the sector disc and one position of the prism corresponding to each individual equidistant section of the image plane 9, that is, the slits of the sector disc are synchronized with the image sections. In the position illustrated in the figure, the slit of the disc 4 exhibits image I so that lens 7 will produce by means of prism 8 the image falling into the direction of the reflector prism 8 at point I. Thereafter, the rotary sector disc will cover



Fig. 24. Landscape selected for illustrating distortion-free image-formation

up the image while the reflector prism 1 continues to revolve, and mount 12 travels to the next field section. Thereupon, the next slit of the sector disc once more exhibits the image. The instrument projects on screen 9 the pictures formed of the successive sections of field by the reflector prism 1. Each picture section appears but for a short time, so that rapid projection produces a coherent panoramic picture band. Fig. 27 represents the procedure of forming a picture

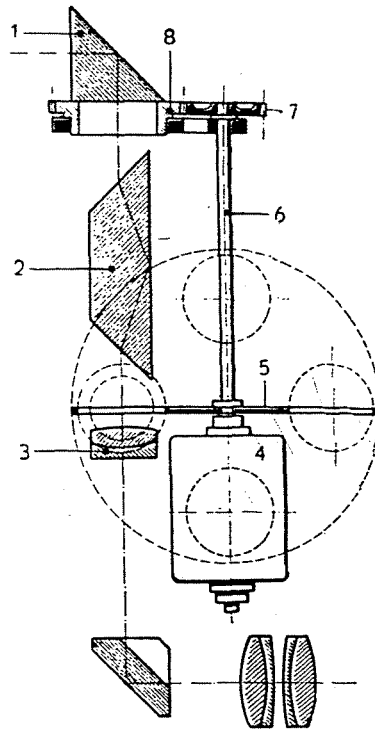

Fig. 25. Rotating-screen arrangement for producing distortion-free panoramic images

band, whereas the picture thus obtained is shown in Fig. 28. However, said picture is not satisfactory as regards definition. It is proposed therefore to modify the system, to work in the manner known for motion picture projectors. The reflector prism will thus revolve intermittently instead of revolving continually. The reflector prism as well as the rotary sector disc and mount 12 will be stopped for a short time during each projection, in the direction of the field of the respective picture section. The systems is either mechanically controlled by means of a maltese cross or a scanning arm arrangement, or it is fitted with optical diffraction elements. These latter optical elements will be treated in a forthcoming paper.

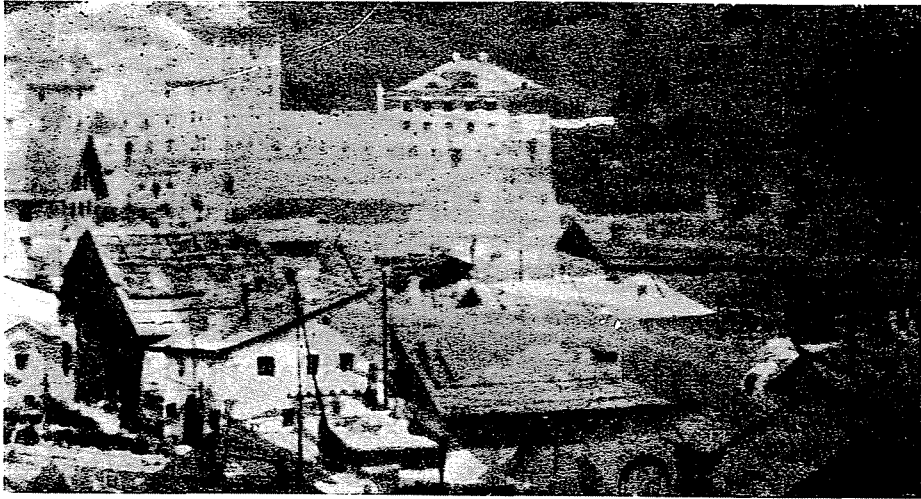

Fig. 26. Image formed by the arrangement shown in Fig. 25

The working of the instrument makes it clear that projection is periodic. It has been found that the human eye, if subjected to continual stimuli of short duration, reacts in an interesting way. The phenomena associated herewith are too complex, and dependent upon too many factors, to be described here in detail. Summarized results, however, offer a basis for computation of image frequency and film speed for panoramic projection which in turn may provide helpful information for the design of the instrument.

Low frequencies may bring about the unpleasant sensation of the separation of impressions. For higher frequencies the phenomenon is called flicker, and it is called scintillation for still higher frequencies. High frequency causes the successive stimuli to merge, giving rise to a uniform sensation of light. According to the Talbot—Plateau law a rapid succession of light stimuli induces a sensation equivalent to continual light stimuli over the scintillation limit, if the amount of light prevailing for the periodic stimuli is uniformly distributed over the whole stretch of time. The sensation of light of short duration being the product of the duration of the sensation with the illumination of the retina or with the luminous flux, respectively, it follows that for the sensation it is the amount of light that matters. For duration of the sensation is independent of the wave length of the radiating energy. The Talbot—Plateau law plays an important part in cinematography and scintillation photometry, thus it is essential, with a view to image projection, to be acquainted with the limit of scintillation and the frequency of merging. This latter for vision has different values by rods and by cones, respectively, and is also dependent on the adaptation of the eye (Ferry—Porter law). For the purposes of the present

study we are interested in the minimum value. Assuming similar conditions, this minimum value is reached, if light-dark ranges are equal for frame repetitions. According to this rule, picture frequency is 25 sec. for up-to-date motion-picture-projection. Taking as a basis the general density of luminous flux of the projection screen, 50 light-dark range picture repetitions are required for

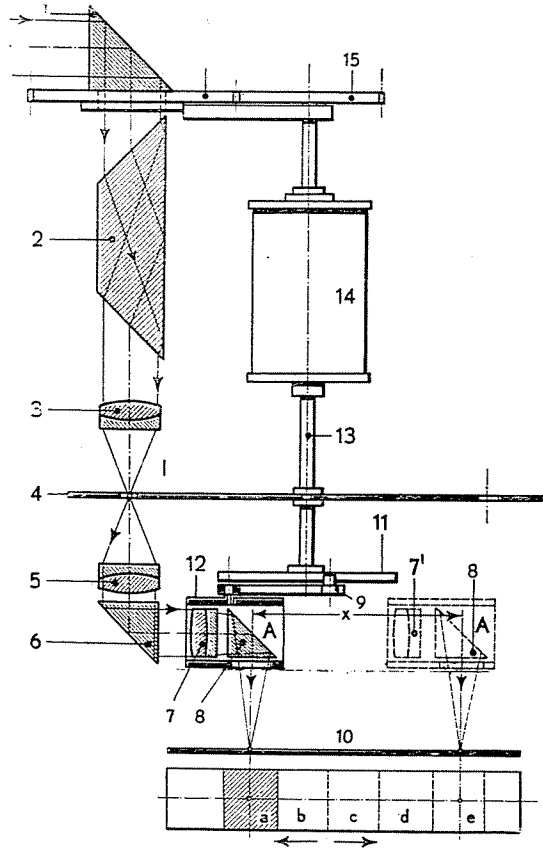

Fig. 27. Formation of a distortion-free panoramic image by the use of a rotating screen and a projector prism of alternating motion

the frequency of merging. In order to obviate scintillation, a rotary sector disc is provided producing two succeeding obscurations of equal duration.

A variation of this procedure is used in connection with panoramic projection. However, frequency of merging should be determined by tests, since the lower this value, the lesser the revolution per minute of the projecting prism, and the speed of the film. With a frequency of 25/sec as starting point, one obtains approximately the following results :

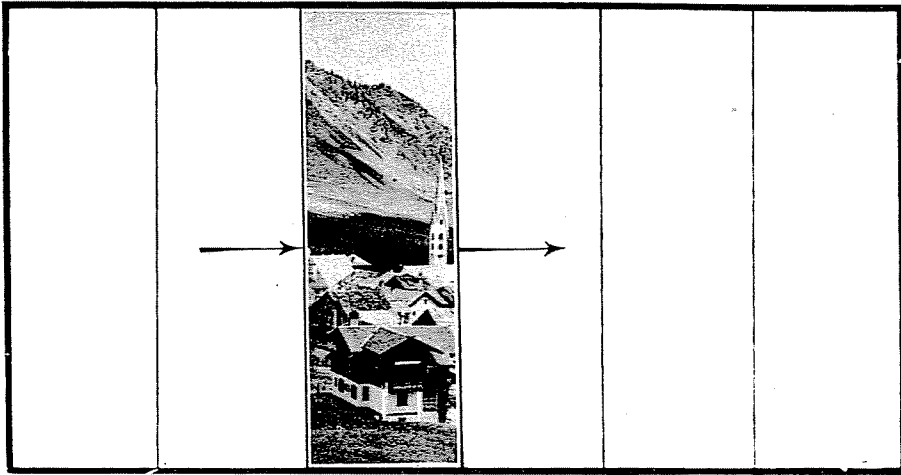

Fig. 28 Explanation of the distortion-free panoramic image obtained by the use of the arrangement diagrammed in Fig. 26

Let the convenient angle of image for the projection be 30° . One picture section is always projected within this angle. The number of picture sections for one revolution of the prism is $360 : 30 = 12$. Since each picture section is individually projected on the corresponding spot with the 25/sec frequency assumed, the revolution per minute of the prism is $12 \text{ by } 25 = 300/\text{sec}$ or 18,000/min. Dividing now one picture frame of the normal cinematographic film into two equal portions, the frame repetition frequency amounts to 150/sec.



Fig. 29. Distortion-free panoramic image composed of juxtaped band images

The above figures should be considered as only rough approximations, intended as general information. Only the realization in practice of the instrument may confirm the assumption, that the revolutions per minute of the reflector prism may be still further reduced. Thus, in the event of projection with inverted optical path, the instrument may be so constructed, that the revolving prism scans the picture frames travelling in opposed direction. Another solution envisaged is to use a semicircular projecting screen instead of a circular one. Preference is given to the semicircular arrangement, because the constancy of image distance, and, in consequence, of definition, can only be ensured by placing the projecting apparatus in the centre of the circle.

For the telescopic projection of the whole horizon the length of the picture band is dependent on the real field of vision of the telescope, amounting to 10 to 14° for the telescopes described. The diameter of the circular field of vision is 20 mm, equalling the length of one side of the circumscribed quadrangle. The number of pictures produced during one revolution of the prism is $360 : 12 = 30$ so that the full length of the band picture is 600 mm. This type of panoramic picture reproduces the whole horizon, thus, the right-hand and left-hand ends of the picture belong together. If, for example, the picture represents an automobile passing along the picture band from left to right, the portion of the car disappearing at the right-hand extremity of the picture will appear at the left-hand extremity. Let us mentally bend the band picture into a cylindrical surface, and the observer stationed in the centre will see a full panoramic picture. The size of the picture is, of course, so small that only the unaided eye may view it from a short distance.

It will be noted that a number of unforeseen and sometimes contradictory optical, optomechanical and psychological factors may eventually play an important part in the projection of circular or semicircular distortion-free pictures.

It is assumed that the principle disclosed may be used to advantage in fields of investigation other than the projection of images.

Summary

The common characteristic of the above described image-forming systems is, that they bring about full panoramic (circular) images either by mechanical means, such as systems of rotary prisms or revolving telescopes, or by optical means where the panoramic image is produced by annular lenses, or by a combination of the two methods.

It is clear from the foregoing, that all optical or optomechanical principles have already been applied for producing panoramic images. These principles may be summarized as follows :

1. Image formation is discontinuous for wide-angle photographic lenses. True, the images obtained are free from distortion, yet these instruments are unsuitable for producing telescopic images, owing to their short focal lengths, which do not allow of considerable magnification and, in addition, the relative apertures of such systems are rather small.

2. Speaking of systems of continuous image formation, the panoramic images formed by annular lenses or annular mirror lenses suffer from serious distortions. Moreover, their mag-

nifying power is relatively low from the viewpoint of telescopes, whereas their cost of production are rather high.

3. Images of the entire horizon can only be obtained by means of lenses of the Hill type, but the images are heavily distorted at the margins. These lenses occupy an intermediate position between photographic and ring lenses.

4. Systems forming panoramic images composed of sections have the advantage of yielding undistorted images of satisfactory magnification and visual field. Both the multiple telescopes and the Lippert telescopes produce discontinuous panoramic images, and require a number of telescopes, each to be separately adjusted. Manufacture of these devices are rather elaborate and costly. The following facts must also be noted in regard of observation :

The panoramic image is afflicted with heavy distortion; unsatisfactory magnifying power and unnatural perspective renders discrimination of the objects difficult.

Whether the scanning of the horizon by means of the swinging reflector prism is continuously or discontinuously, effected slowly or rapidly, a full command over the entire field can only be achieved by taking advantage of the observer's visual memory. In case of a change in the sighting line, determination of the relative position in relation to the basic direction, that is, orientation, is rather cumbersome, even if accessory instruments are employed.

The target is to produce wide-angle, undistorted panoramic images of high magnification, permitting simultaneous coverage of the whole field.

Professor N. BÁRÁNY Budapest XI., Gombocz Zoltán utca 17, Hungary.