

Interval Type2 Fuzzy Logic Based STATCOM Controller for Stabilizing a Mixed Electrical Network System

Abdellah Kadri^{1*}, Salim Makhloufi¹

¹ Energy, Environment and Computer Systems Laboratory, Department of Sciences of Technology, Faculty of Sciences of Technology, Ahemd Draia University, 01000 Adrar, 6 Rue National, Alegria

* Corresponding author, e-mail: kadri.det@univ-adrar.edu.dz

Received: 07 January 2022, Accepted: 18 July 2022, Published online: 30 August 2022

Abstract

Adding renewable energy plants to the electrical grid reduces the performance of energy systems. This results in problems including power fluctuations and poor voltage quality. This paper presents an interval type2 fuzzy logic-based controller, consisting of current and voltage regulators, that is applied to a STATCOM to regulate the DC voltage under various operating conditions. A membership functions not used before in this field have been used to generate IT2FL sets output. The STATCOM has been connected with the high voltage bus bar in order to use one STATCOM for all the loads. According to comparative studies, the proposed method outperforms traditional PI and type1 fuzzy logic-based controllers.

The simulation has been implemented using MATLAB/SIMULINK software and the results confirm the feasibility of the proposed system.

Keywords

STATCOM, type2 fuzzy logic controller, renewable energy, power system stability

1 Introduction

Integration of wind and solar power plants into the electrical network has led to creation of various problems, such as voltage and power variations.

This necessitated the use of devices called Flexible Alternating Current Transmission Systems (FACTS) since they are able to monitor the network conditions in a very fast manner. Those devices can be used for AC transmission systems to increase voltage reliability and stability of the supplied power in both operating and intermittent states of the electrical power system [1]. On the other side, the Static Temporary Compensator (STATCOM) is one of these devices that play an important role in regulating the voltage. The regulation is done by controlling the flow of the reactive power of the power system. A three-phase inverter controls the voltage across the transformer leakage reactance, thus, generates a correction of the reactive power that is transferred between the power grid and the STATCOM [2].

Authors [3] suggested a method for PID- STATCOM controller design based on root counting and signature theory using computer-aided calculation. In [4] a STATCOM with adaptive Proportional Integral (PI) control has been used, it can self-adjust PI gains during turbulence,

regardless of operating condition change; this gave better results than using only the PI controller. To improve voltage stability, authors in reference [2] used a STATCOM device and a 48-pulse Voltage Source Switch (VSC) to reduce harmonics distortion. In [5], proposed a Distributed STATCOM (DSTATCOM) controller based on fuzzy logic design to enhance power quality and power distribution system stability. However, [6–9] PI controller has been used to control STATCOM. Fuzzy logic has been used to adjust the parameters of the PI controller of the DC voltage regulator during the transient states in case of load changing; this gave more stability to the DC voltage. [10] used Genetic Algorithms to optimize Fuzzy Logic Controllers (FLCs) for DSTATCOM to improve power quality and transient behaviour. In [11], a STATCOM has been proposed to regulate the voltage of the conductor in a given bus bar in many abnormal situations, and to compare two monitoring methods; the first is the conventional control using only PI controller, the second used an adaptive fuzzy logic self-tuning PI controller [11]. An improved gray wolf algorithm has been proposed in [12] for adjusting a fuzzy logic DSTATCOM controller in order to improve system power quality and

power distribution stability. [13] proposed controlling the rotational speed of the wind turbines based on an adaptive fuzzy logic PID controller to give smooth control of the tilt angle which in turn has adjusted the wind turbine speed [13].

Type1 fuzzy logic controller (T1FLC) cannot efficiently handle input uncertainties. To boost the uncertainty management performance, Zadeh proposed the principle of type2 fuzzy sets in [14] to address the constraint of type1 fuzzy sets limitations. In [15] authors implemented a STATCOM based on interval type2 fuzzy logic (IT2FL) to mitigate the voltage changes caused by changes in load and intermittent generation of photovoltaic (PV) arrays. In [16], authors have compared performance of DSTATCOM based on type1 and type2 fuzzy logic controllers for electric power improvement and Power factor correction. An IT2FL control system has been presented in [17] in a smart grid, for the STATCOM to stabilize voltage bus-bars in the presence of faults or forced wind farm outages because there are numerous possible scenarios in the power system, they used the Taguchi method in the experiment design. [18] used IT2FL to regulate the DC voltage as well as updating the step size of the algorithm to improve the performances of the DSTATCOM. [19] used IT2FL based STATCOM to reduce voltage variations caused by irregular photovoltaic power generation.

The rest of the article is organized as follows: Section 2 is gives the background of IT2FL systems. Section 3 describes the proposed method based on the IT2FL for reducing the voltage fluctuations in the power system. Simulation results related to a power system integrating renewable energy sources are presented in Section4. The paper ends with a conclusion.

2 Principle of STATCOM

STATCOM is a shunt-connected device that can either generate or absorb reactive power to regulate voltage. It utilizes pulse width modulations (PWM) witching technique for this purpose. The STATCOM schematic diagram is shown in Fig. 1. It contains a coupling transformer, a voltage source inverter (VSI) and a DC capacitor. Input voltage is delivered to the system through the reactance of the coupling transformer. The active and reactive power exchange between STATCOM and the network is achieved by controlling the voltage across the reactance [20].

3 Proposed IT2FL based STATCOM

A STATCOM are current or voltage source converters based, the voltage source is most common. Unless an extra

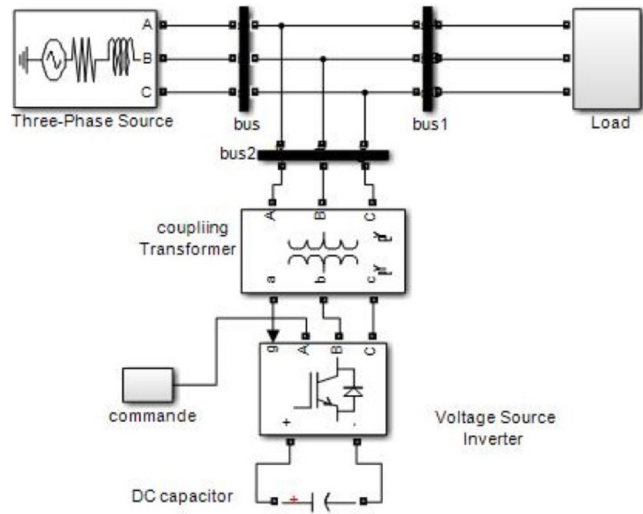

Fig. 1 STATCOM block diagrams

storage device for energy is added to the STATCOM's DC bus, the STATCOM's principal role is to inject or to absorb reactive power to regulate grid voltages. Fig. 2 depicts the STATCOM model utilized.

The DC voltage (V_{dc}) measured on the capacitors is compared to the DC voltage reference ($V_{dc,ref}$) to obtain the error signal entering the PI controller and that's in the case of a DC voltage regulator. The proportional and integral gain values were determined through trial and error and are as follows: $kp = 0.001$, $ki = 0.15$, where kp is the proportional gain, and ki is the integral gain.

In this paper, the proposed IT2-FL controller is implemented for DC voltage regulation as shown in Fig. 3. It uses the error of DC voltage and the variation of this error to generate the current reference.

4 STATCOM sizing

The dc bus voltage must be more than the peak of line voltage ($V_p = 1.25$ kV). The V_{dc} is calculated from (Eq. (1)) [21–25]:

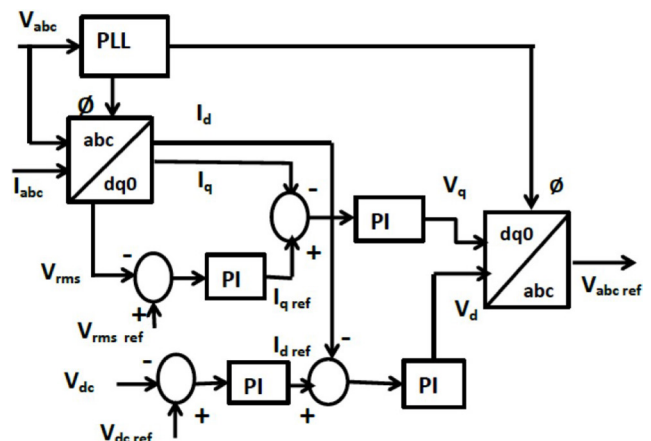

Fig. 2 Block diagram of STATCOM control

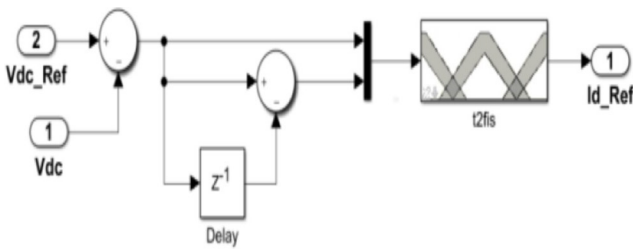

Fig. 3 DC Voltage Regulator Model Using IT2-FCS

$$V_{dc} = (2\sqrt{2}(V_p / \sqrt{3})) / m, \tag{1}$$

where m is the modulation index with maximum value of 1. Hence minimum V_{dc} is: $V_{dc} = 2041.24$ V. A value of 2400 V is used in this work. If the current ripple i_r is allowed to be 15%, the inductance can be calculated as [24, 25]:

$$L_c = ((\sqrt{3}/2)mV_{dc}) / (6 \cdot a \cdot f_s \cdot i_r), \tag{2}$$

where f_s is the switching frequency, which in this case is set to 10 kHz. During transients, the current rating evolves between 120% and 180% percent of its steady-state value [26]. During transients, inductance calculation uses a current rating of 120% ($a = 1.2$) of steady-state current.

The inductance value is $L_c = 0.8$ mH obtained by substituting the values of V_{dc} , f_s and current ripple i_r in Eq. (4). The voltage drop V_d across the alternating current I_s is calculated using:

$$V_d = 2 \pi L_c f_s I_s = 68.75 \text{ V} \approx 5.5\% \text{ of } 1250 \text{ V}. \tag{3}$$

The energy transfer from capacitor to network to provide reactive power is calculated as:

$$\text{Energy transfer} = 3 V_p I_s t, \tag{4}$$

where t is the response time.

An 8% drop in the dc link voltage is taken into account during transients. A drop in dc bus voltage of 8% means that it ranges from 2400 to 2208 V (V_{dc1}). The energy transfer is:

$$C_{dc} [(V_{dc})^2 - (V_{dc1})^2] = 3 V_p I_s t. \tag{5}$$

A value of the DC bus capacitance $C_{dc} = 9680 \mu F$ is obtained by substituting the values of V_{dc} , V_{dc1} , V_p , I_s and $t = 0.01$ s into Eq. (5). A value of 10000 uF has been taken in this work.

5 Type2 fuzzy logic controllers

Because of their capacity to deal with uncertainty, type2 fuzzy logic controllers (FLCs) have grown in popularity

in recent years. The type2 FLC employs type2 fuzzy sets to describe the controller's inputs and/or outputs. Type2 FLC and type1 FLC have the same configuration except that type2 controller requires an additional step called the type reduction. As shown in Fig. 4, the steps in a type2 FLC are fuzzification, rule base, inference system, Type Reduction and Defuzzification [22].

5.1 Fuzzification

The inputs are converted into fuzzy language values at this step (type2 fuzzy sets). Gaussian membership extends the variables of input and output to type2 intervals; input or output variable range is divided into seven levels: N-b (negative-big), N-m (negative-medium), N-s (negative-small), Z-e (zero), P-s (positive-small), P-m (positive-medium) and P-b (positive-big). All membership functions for IT2FL inputs $e(t)$ and $\Delta e(t)$ are defined on the common normalized domain $[-200, 200]$ as shown in Fig. 5.

5.2 Rule the base

The rule base is a collection of Logical grammatical rules in the following form:

- if x_1 is F_1^i and x_2 is F_2^i and x_n is F_n^i Then $y^i = G^i$;
- ($i=1,2,...,n$);
- x^i and y^i are the input and output of the i^{th} rule respectively;
- $F_1^i \dots F_n^i$ are antecedent linguistic terms.

Through these rules, the control decision is determined by the inference engine. The rules are set based on the knowledge that we have about the system. In this study there are forty-nine rules, presented in Table 1.

5.3 Inference engine

At this level fuzzy rules are combined by the Inference engine and the crisp inputs are transformed to the interval type2 fuzzy output sets.

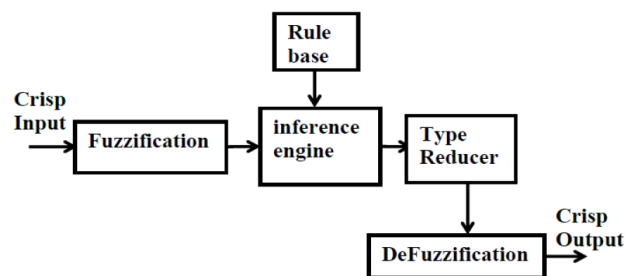

Fig. 4 Type2 fuzzy logic controller structure

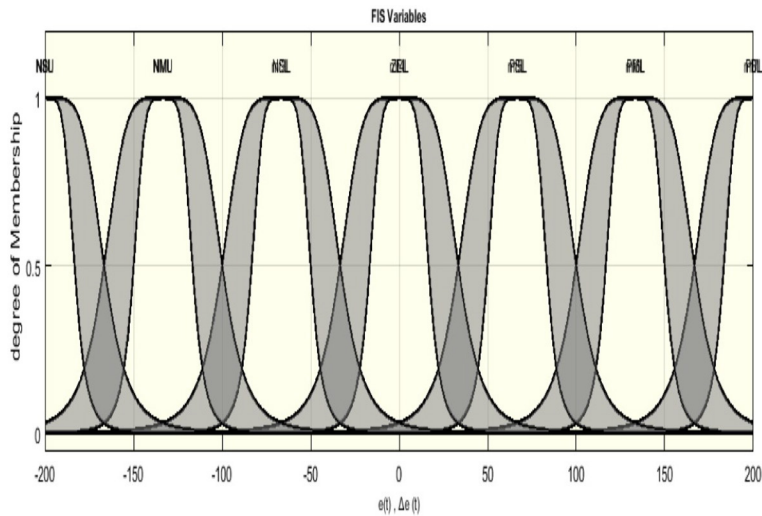

Fig. 5 Membership functions of e (t) and Δe (t)

Table 1 Rule base

Error/ Derror	N-b	N-m	N-s	Z-e	P-s	P-m	P-b
N-b	N-b	N-b	N-b	N-b	N-m	N-s	Z-e
N-m	N-b	N-b	N-b	N-m	N-s	Z-e	P-s
N-s	N-b	N-b	N-m	N-s	Z-e	P-s	P-m
Z-e	N-b	N-m	N-s	Z-e	P-s	P-m	P-b
P-s	N-m	N-s	Z-e	P-s	P-m	P-b	P-b
P-m	N-s	Z-e	P-s	P-m	P-b	P-b	P-b
P-b	Z-e	P-s	P-m	P-b	P-b	P-b	P-b

5.4 Type reduction and defuzzification

The inference engine type2 interval fuzzy outputs are transformed into the type1 interval fuzzy in order to carry out defuzzification, and that's in the type reduction stage. The main difference between the fuzzy logic system type1 and type2 is the type reduction block. Type Reduction methods are classified into several categories. The center of Sets (COS) type reduction, advanced by Mendel is the most widely used and is expressed as [23]:

$$Y_{cos}(x) = [y_l, y_r], \tag{6}$$

where:

- Y_{cos} : interval set determined;
- Y_l : left limit;
- Y_r : right limit.

$$y_l = \frac{\sum_{i=1}^M f_l^i y_l^i}{\sum_{i=1}^M f_l^i}, \quad y_r = \frac{\sum_{i=1}^M f_r^i y_r^i}{\sum_{i=1}^M f_r^i} \tag{7}$$

Ones the type reduction is carried out, type reduced sets are defuzzified to provide the crisp result. The set resulting from the type reducer has been defuzzified using the average of y_l and y_r [24], so the defuzzified output is:

$$y = \frac{y_l + y_r}{2} \tag{8}$$

6 Studied networks

The studied network has been designed thanks to the Matlab/SIMULINK software, and it is represented in Fig. 6. It consists of three different power sources: 3 phase voltage source (25 kv, 100MW, 60 Hz), photovoltaic power station (400 V, 1 MW), wind station (9 MW, 575 V), 8 transmission line, 2 Fixed load (load1: 3 MW, 0.2 MVA, 25 KV, load2: 400 V, 1 KW) and 2 transformers (the first is 575 V / 25 KV, the second is 400 V / 25 KV). The nominal power is 3 MVA and the nominal voltage is 25 KV. Table 2 summarizes the STATCOM parameters.

7 Simulation results

Here will be presented the simulation results in the following three cases:

1. 3MW-1MVAR load increase;
2. 3 MW -1 MAR load disconnects;
3. Two-phase fault to the ground.

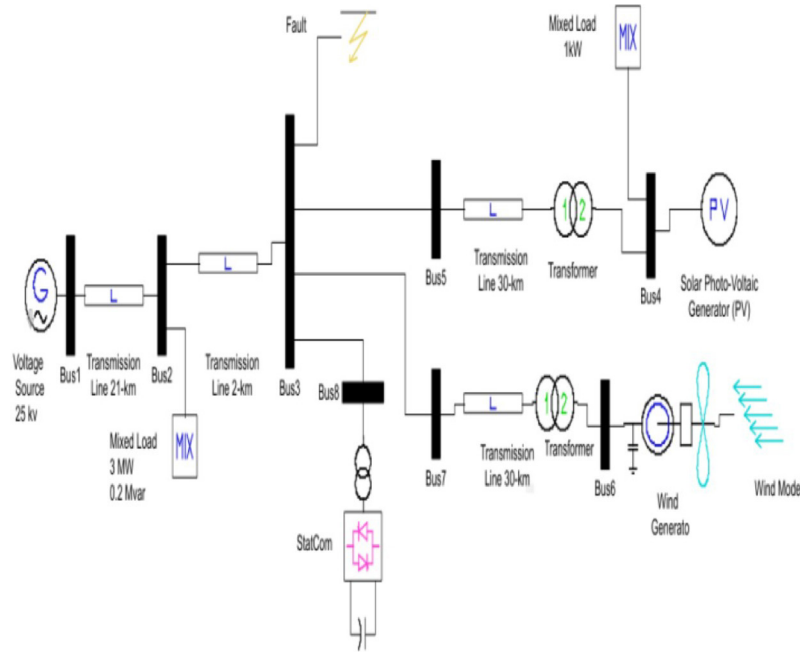

Fig. 6 Studied networks

Table 2 STATCOM parameters

Linear transformer	2.5e6V.A, 60 Hz, 1.25/25 kV
L_C	800e-6 H
C_{dc}	10000e-6 F
V_{dc}	2400 V
k_i	0.15
k_p	0.001

We will also compare the DC voltage when using a PI controller, a types1 fuzzy logic controller, and an interval types2 fuzzy logic controller. Furthermore, the energy exchange in the three scenarios will be compared.

7.1 Case1: load increase

In this case, a load (3 MW – 1 MVAR) has been added to the power system during the time interval (0.15–0.3) seconds of the simulation. Fig. 7 shows the voltage amplitude at Busbar 3 when the load is added to the system and without STATCOM.

Fig. 8 shows the voltage of the Busbar 3 when the load (3 MW – 1 MVAR) is connected to the Power system with the STATCOM.

It can be noticed from Fig. 7 that the voltage amplitude at the Busbar 3 is equal to the nominal value before connecting the load (3 MW – 1 MVAR). During the time interval (0.15 sec, 0.3 sec), and after introducing the load, the voltage drops below the nominal value by 4%. It is clear from Fig. 8 that the STATCOM device has compensated the decrease in voltage due to the load connection so that it

remains constant at the nominal value. In addition, the voltage is smoother in the case of type2.

Fig. 9 shows the DC voltage using the three types of STATCOM. It also turns out that in the case of type2 Fuzzy Logic controller; there is a good control of the voltage, so that the amount of constant voltage deviation from the nominal value is less compared to the use of PI controller and type1 fuzzy logic controller.

Fig. 10 shows the exchange of the reactive and active power between the STATCOM and the power system.

7.2 Case2: load disconnect

In this case, a load disconnect (3 MW – 1 MVAR) from the power system during time interval (0.15 sec, 0.3 sec) of the simulation is performed. Fig. 11 shows the voltage amplitude at Busbar 3 when the load is disconnected from the system and without STATCOM.

As for Fig. 12, it shows the voltage response of Busbar 3 when disconnecting the load (3 MW – 1 MVAR) from the power system using STATCOM with the three control methods (PI, type1 and type2 fuzzy logic controllers).

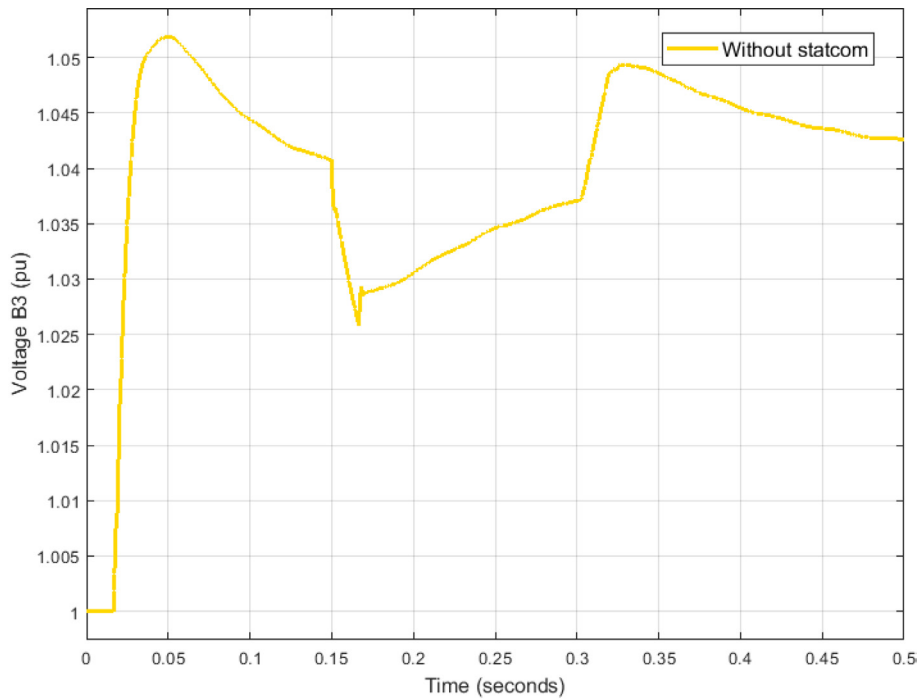

Fig. 7 Voltage Magnitude in Busbar 3 without STATCOM (case1)

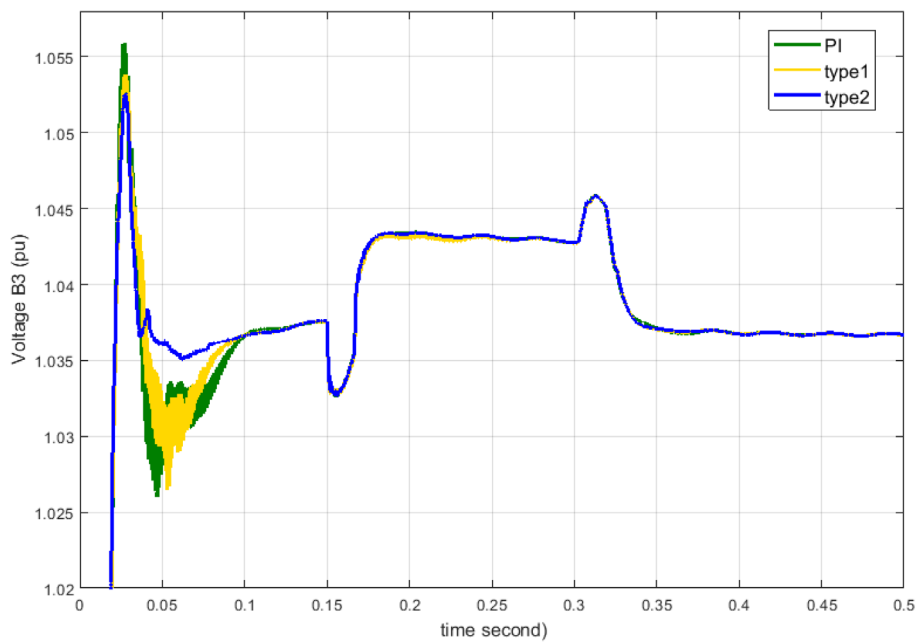

Fig. 8 Voltage response obtained by the three methods in Busbar 3 with STATCOM (case1)

It can be noted from Fig. 12 that the voltage level rises to 1.05 pu in the time interval (0.15 sec, 0.3 sec). Voltage in Busbar 3 is compensated using the three controllers mentioned above as shown in Fig. 12. The results of the type2 fuzzy logic controller method show an improvement in the voltage profile. The voltage waveform after compensation by type2 fuzzy logic method has less overshoot and achieves steady state faster than traditional PI and type1 fuzzy logic.

As shown in Fig. 13, the DC voltage in the case of using the PI controller reaches a maximum value of 40% greater than the reference value and then stabilizes on this value. In the case of using the types1 and types2 fuzzy logic controllers the DC voltage reaches a maximum value of 33% of the reference value and then settles on this value.

However the pic takes less time in the case of the type2 fuzzy logic controller. Fig. 14 shows the active and

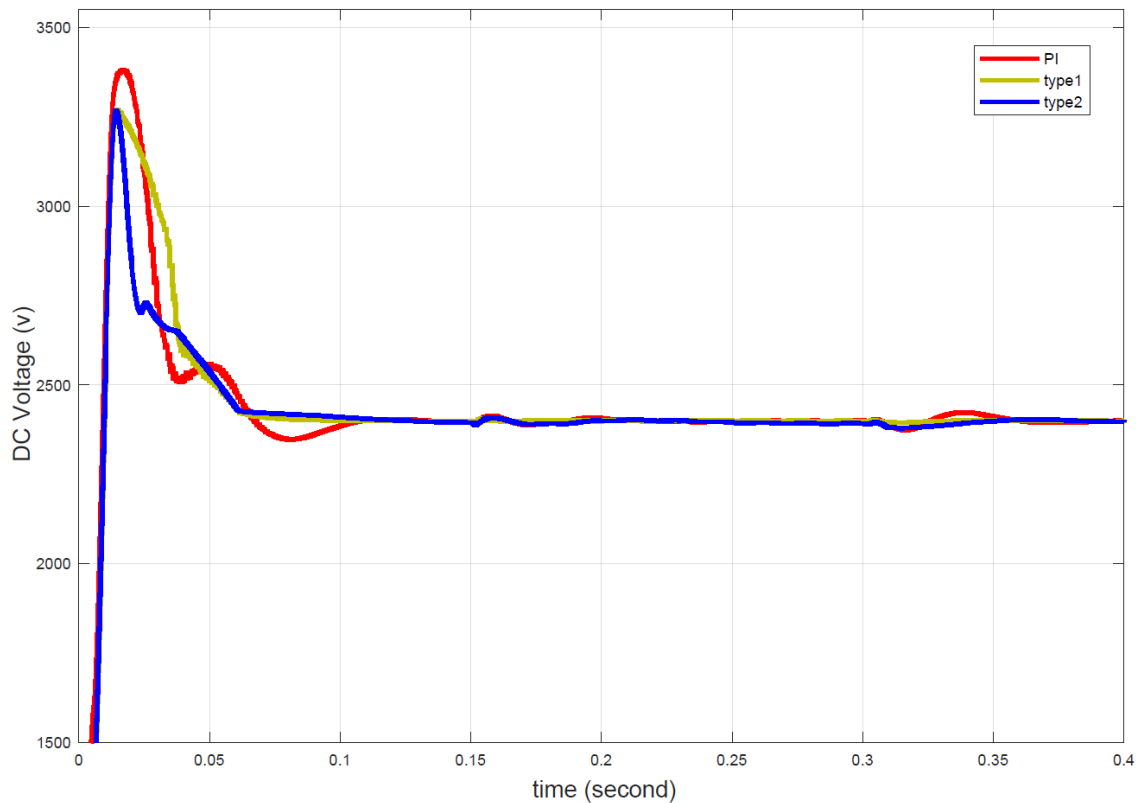

Fig. 9 DC Voltage using PI, type1, and type2 fuzzy logic controllers (case1)

reactive power exchanged between the power system and the STATCOM. During the load disconnect period, the reactive energy is positive (absorbed from the power system) in order to compensate for the rise in voltage. From Figs. 13 and 14 it can be concluded that the type2 fuzzy logic controller is better than type1 fuzzy logic controller and PI controller.

7.3 Case3: two-phase fault with ground

In this case a Two-phase fault with ground is applied to the system during the time interval (0.3 sec, 0.5 sec). The power system experiences a voltage drop (0.94 pu) under those conditions. Figs. 15 and 16 show the magnitude of the voltage with and without STATCOM. When the STATCOM is inserted into the system under consideration, it can be noticed that the device has adjusted the voltage and made it constant at the nominal value. Therefore, this is done by exchanging the reactive power with the power system. That is, when a voltage drop occurs, the STATCOM device injects reactive power.

Fig. 17 shows the DC voltage, with the three controllers. Fig. 18 shows the reactive power provided by the STATCOM using the three methods mentioned above. STATCOM generates reactive power (negative value)

due to sudden voltage drop caused by the two-phase fault with the ground, to raise the voltage on the Busbar 3. The results show that the DC voltage fluctuates with the type2 fuzzy logic controller less than both the type1 fuzzy logic controller and the PI controller.

8 Voltages Total Harmonic Distortion (THD)

As per the IEEE 519-2014 standard [27], the THD should be less than 5%. Table 3 shows that the THD of the voltage of Busbar 3 is within the standard for load increase and Load disconnect for the three methods. However, for the Two-phase fault with ground THD is not within the standard for the three methods.

9 Conclusion

In this paper, an interval type2 fuzzy logic based STATCOM is presented to reduce voltage fluctuations in a power system including PV and wind farms.

Three cases involving load increase, load disconnect and two-phase fault with ground has been studied. Simulation results indicate that the interval type2 fuzzy logic controller is superior to traditional PI controller and type1 fuzzy logic of the STATCOM.

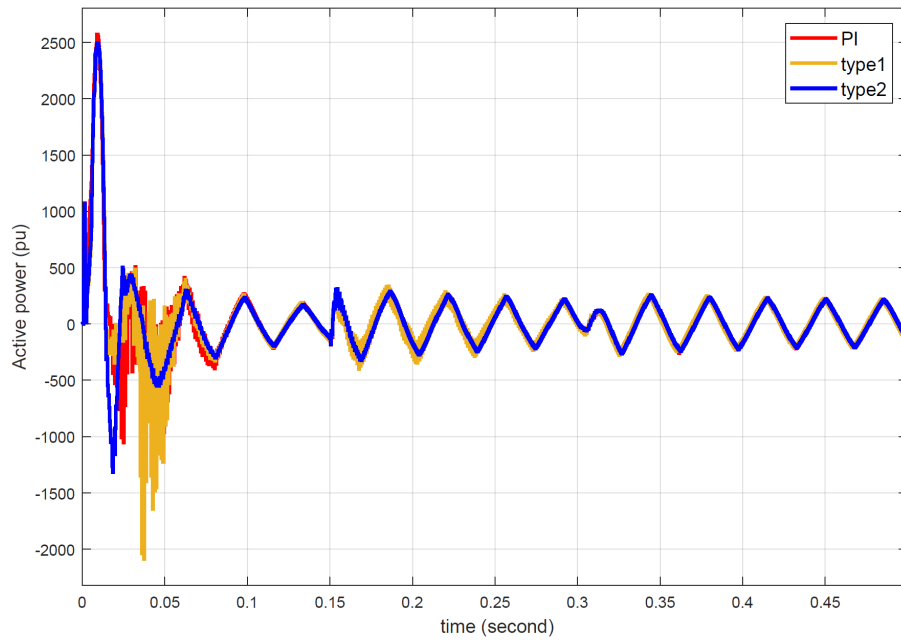

(a)

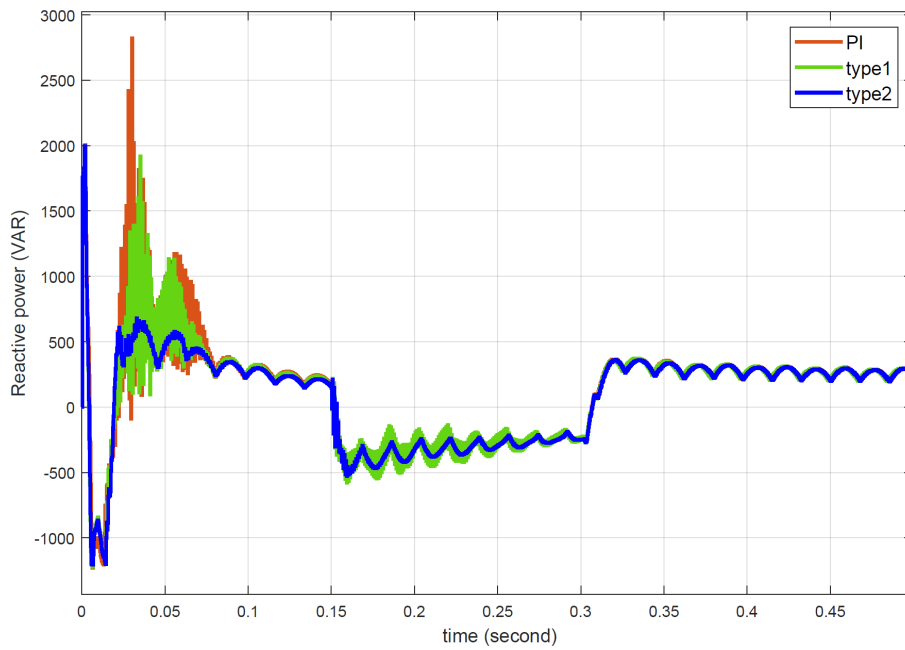

(b)

Fig. 10 power exchange between STATCOM and the power system using PI controller, type1 and type2 fuzzy logic controllers (case1); (a) Active power; (b) Reactive power

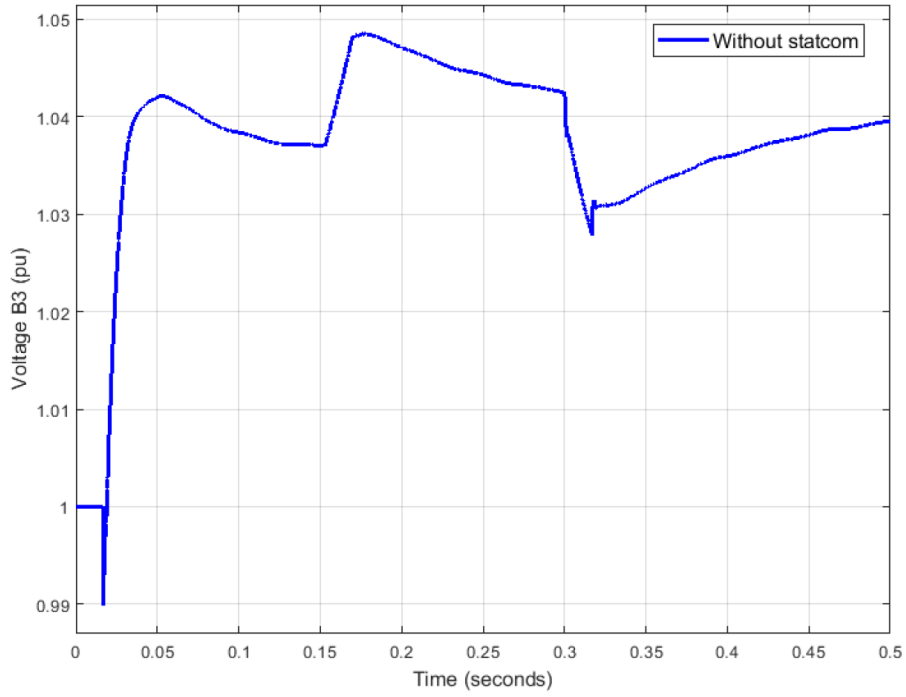

Fig. 11 Voltage magnitude in Busbar 3 without STATCOM (case2)

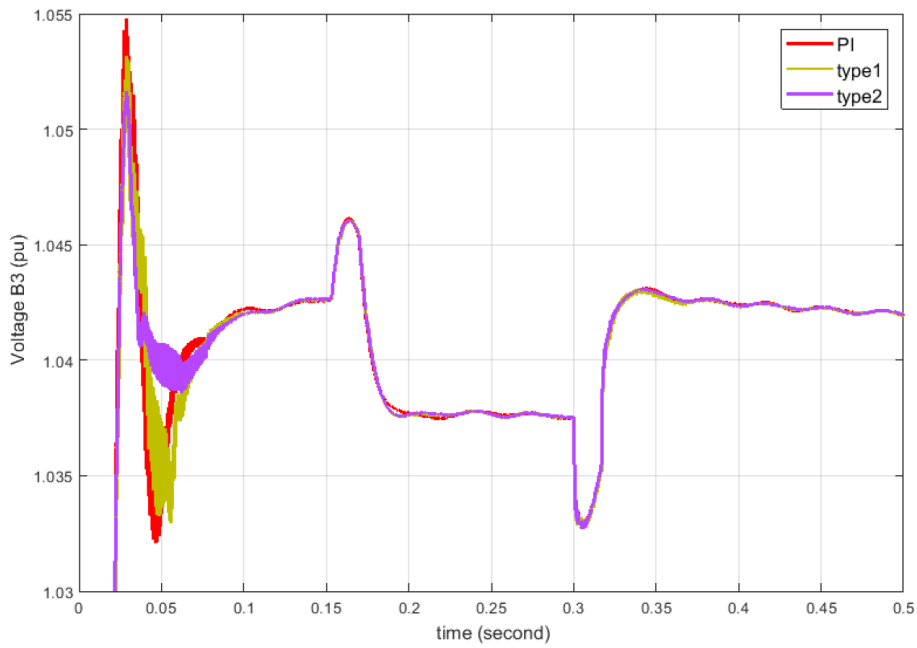

Fig. 12 Voltage response obtained by the three methods in Busbar 3 with STATCOM (case2)

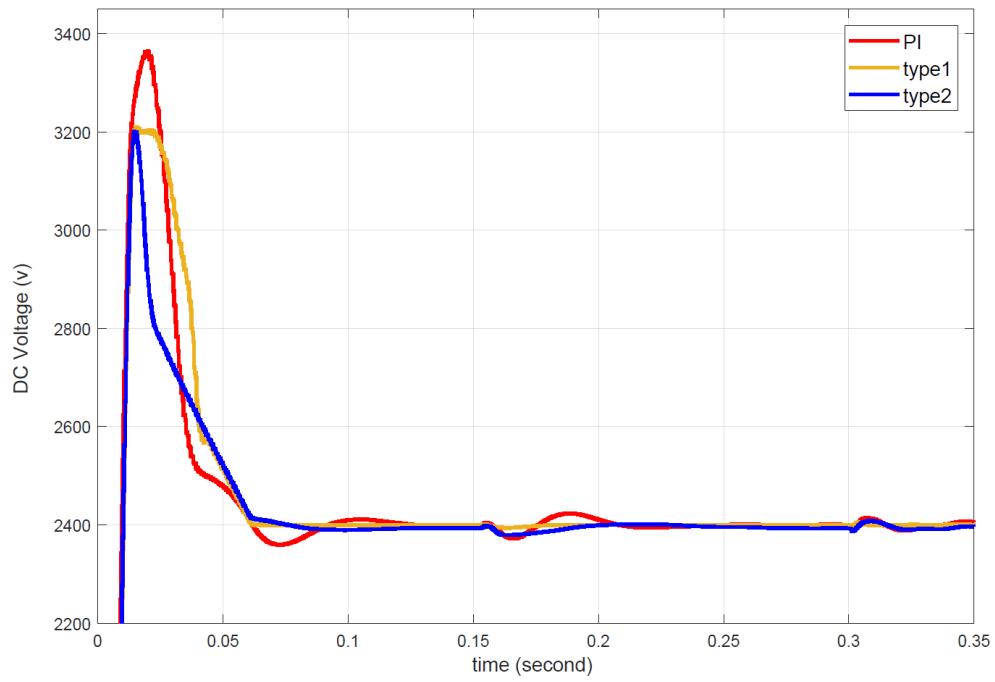
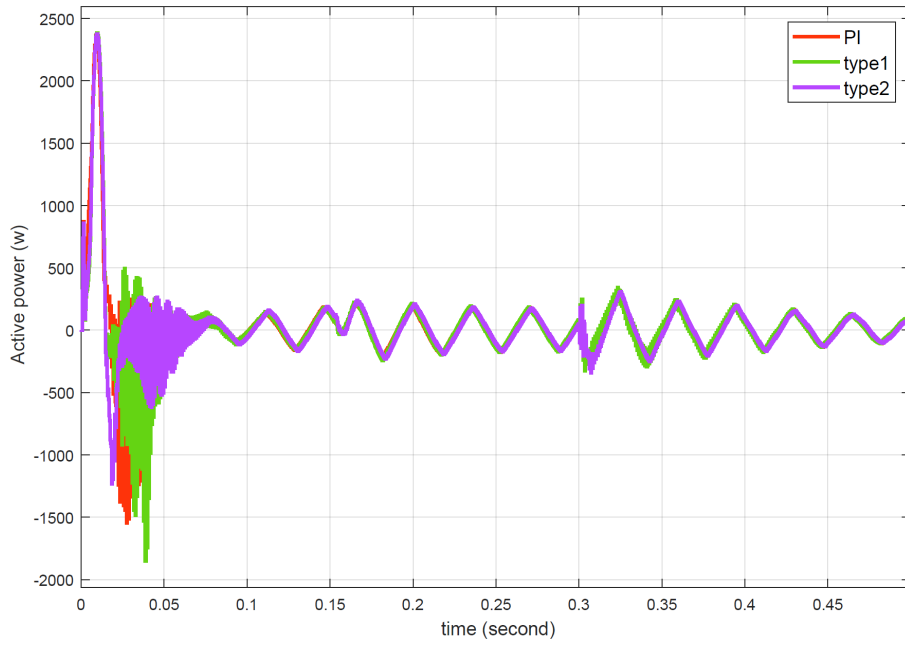
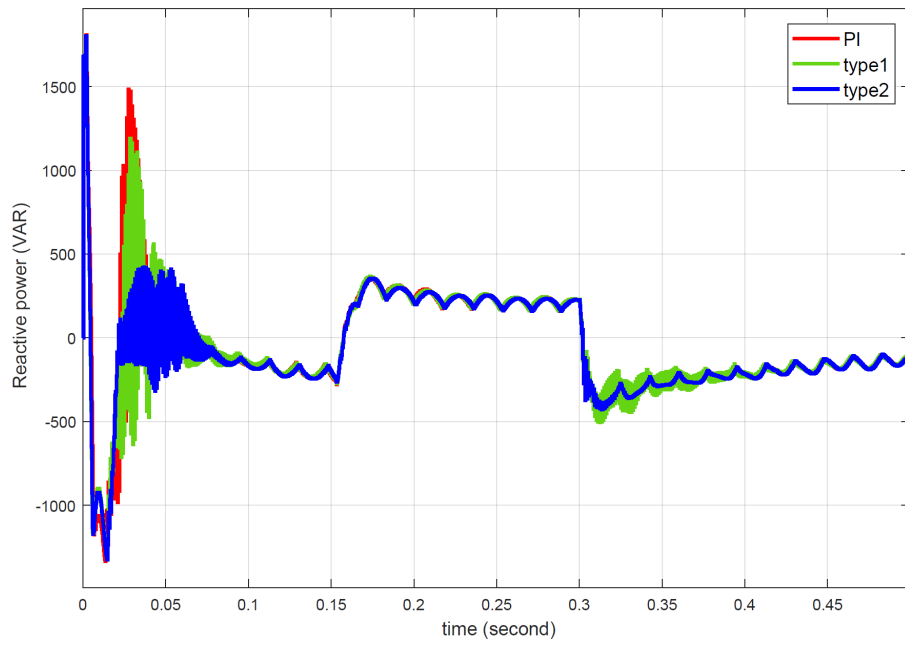

Fig. 13 DC Voltage using PI, type1, and type2 fuzzy logic controllers (case2)



(a)



(b)

Fig. 14 Power exchange between STATCOM and the power system using PI controller, type1 and type2 fuzzy logic controllers (case2); (a) Active power; (b) Reactive power

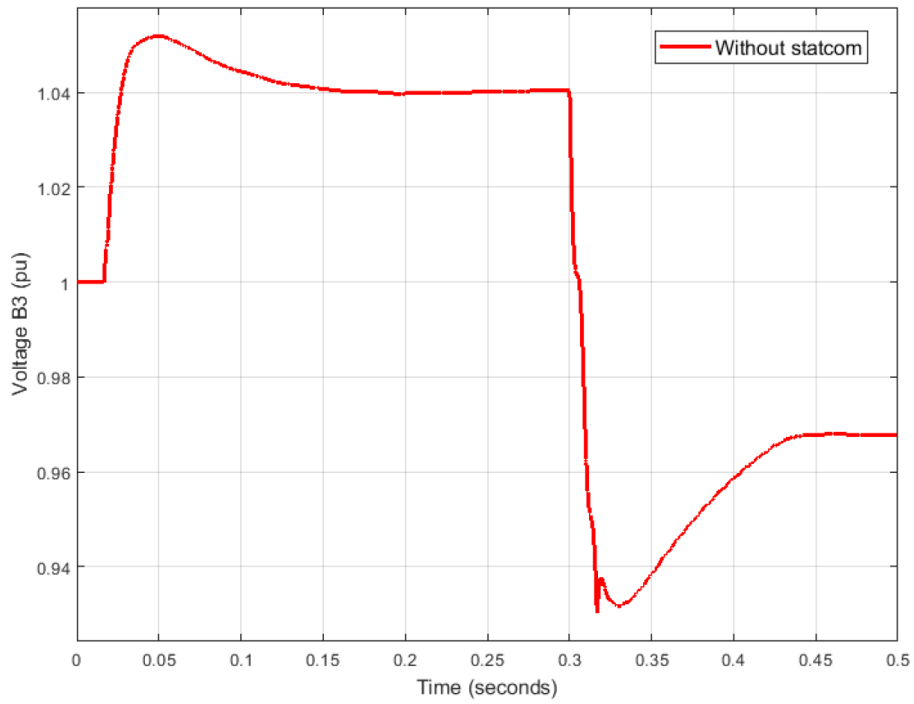

Fig. 15 Voltage magnitude in Busbar 3 without STATCOM (case3)

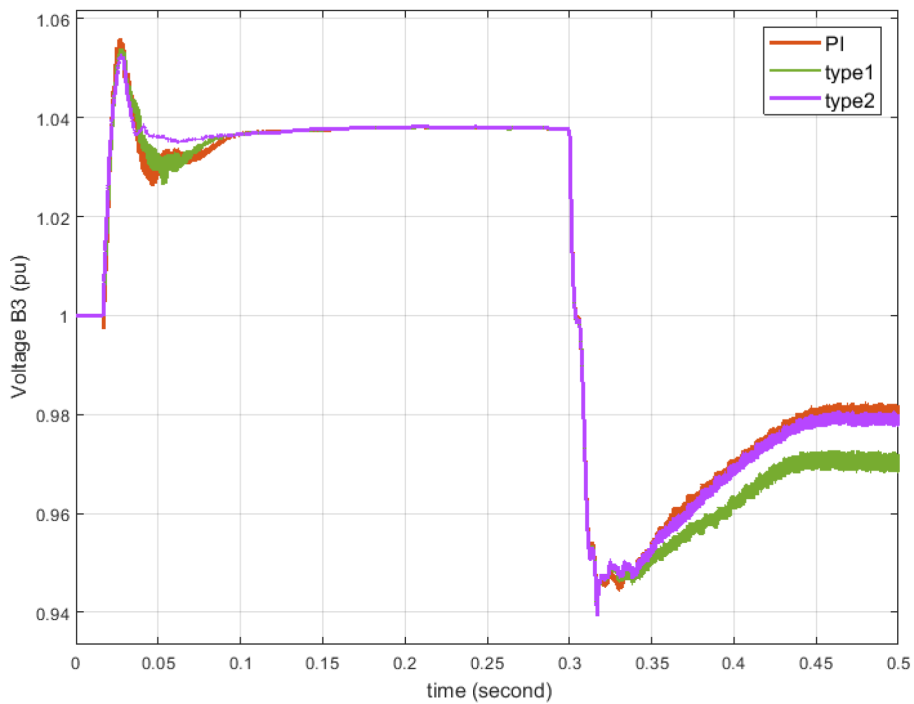

Fig. 16 Voltage response obtained by the three methods in Busbar 3 with STATCOM (case3)

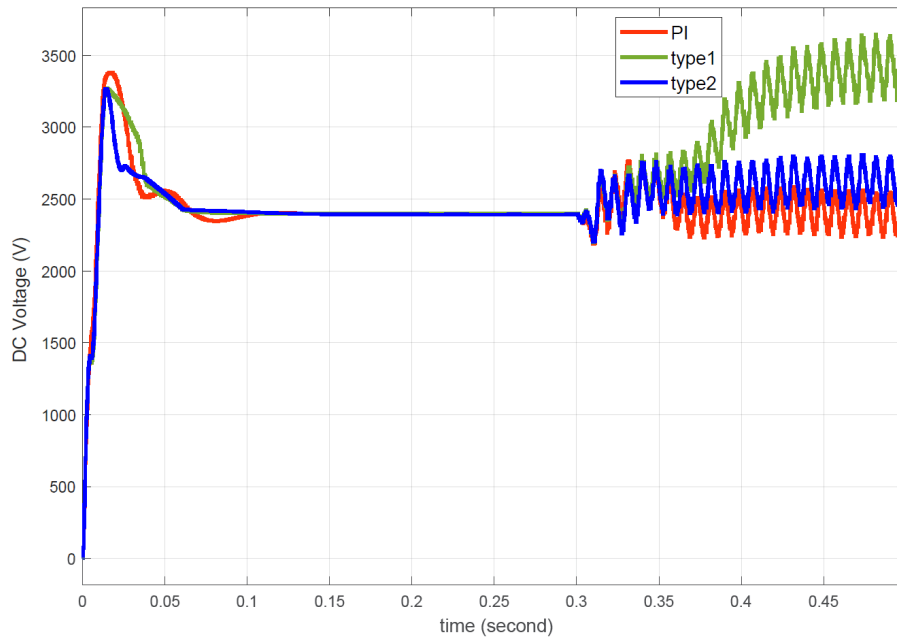
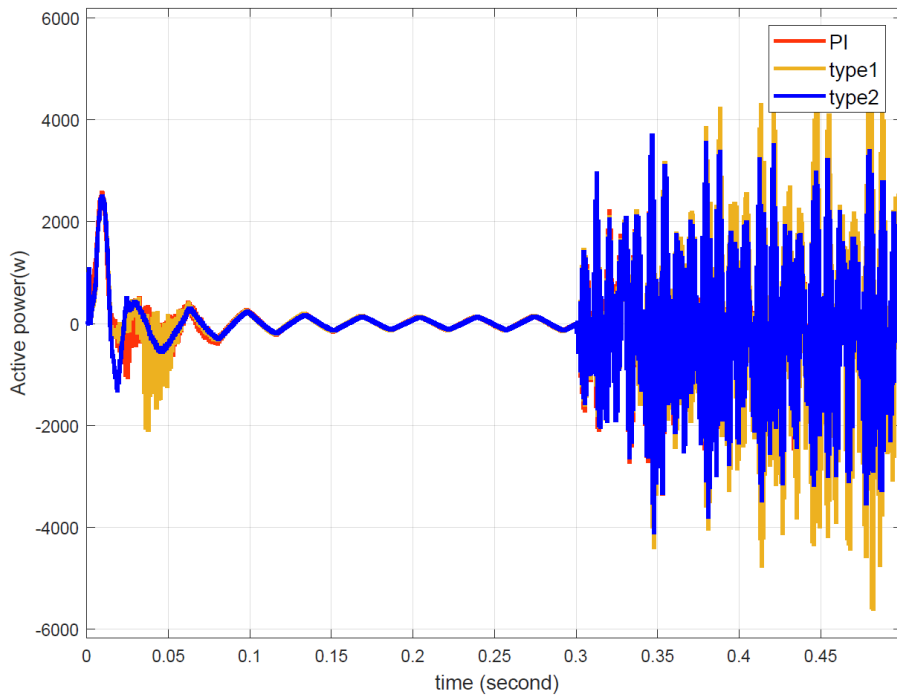
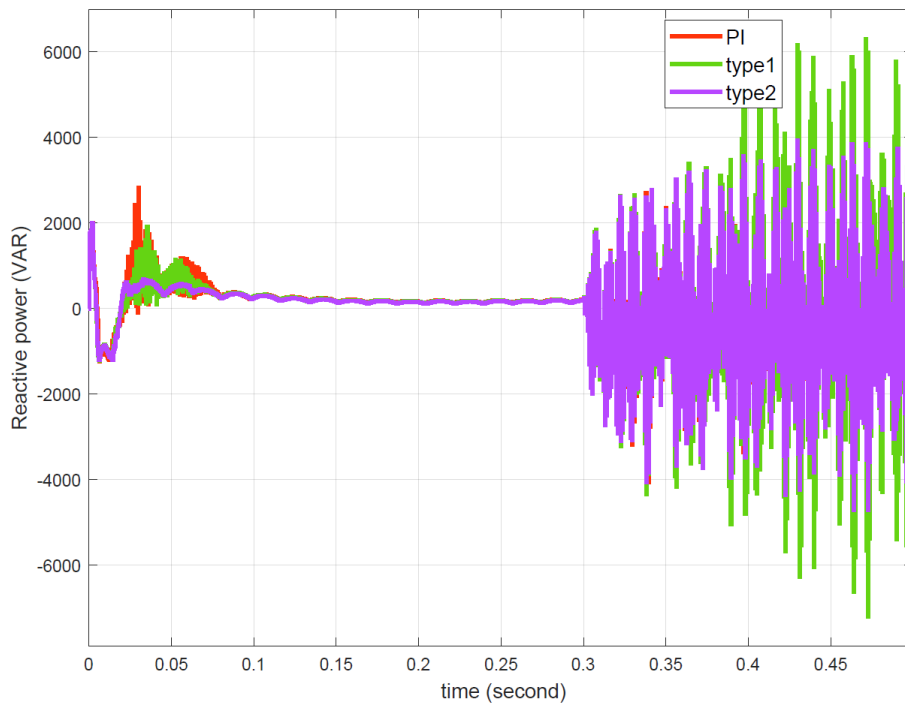

Fig. 17 DC Voltage using PI, type1, and type2 fuzzy logic controllers (case3)



(a)



(b)

Fig. 18 power exchange between STATCOM and the power system using PI controller, type1 and type2 fuzzy logic controllers (case3); (a) Active power; (b) Reactive power

Table 3 voltage B3 THD

	pi	Type1	Type2
Load increase	3.04	3.57	3.05
Load disconnect	2.59	2.89	2.59
Two-phase fault with ground	28.55	30.77	29.20

References

- [1] Ponnurugavel, P. S., Ghouse, S. M. "Design and modeling of fuzzy and model predictive controllers for STATCOM to enhance transient stability of power system", *International Journal of Engineering and Technology*, 5(3), pp. 2609–2619, 2013.
- [2] Xi, Z., Bhattacharya, S. "STATCOM Control and Operation with Series Connected Transformer Based 48-pulse VSC", In: *IECON 2007 - 33rd Annual Conference of the IEEE Industrial Electronics Society*, Taipei, Taiwan, 2007, pp. 1714–1719. ISBN 1-4244-0783-4 <https://doi.org/10.1109/IECON.2007.4460359>
- [3] Pang, C., Kezunovic, M. "A new approach to PID controller design of STATCOM", In: *2008 40th North American Power Symposium*, Calgary, AB, Canada, 2008, pp. 1–6. <https://doi.org/10.1109/NAPS.2008.5307412>
- [4] Xu, Y., Li, F. "Adaptive PI Control of STATCOM for Voltage Regulation", *IEEE Transactions on Power Delivery*, 29(3), pp. 1002–1011, 2014. <https://doi.org/10.1109/TPWRD.2013.2291576>
- [5] Sagar, S., Satti, R. "Fuzzy Logic Control of D-STATCOM for Improving Power Quality and Dynamic Performance", *International Journal of Innovative Technologies*, 6(2), pp. 0487–0490, 2018.
- [6] Shaaban, F., Harmoosh, Z., Alsari, E. "Enhancement of voltage stability in power transmission networks using static compensator (STATCOM) based on fuzzy logic", *Tishreen University Journal for Research and Scientific Studies - Engineering Sciences Series*, 39(3), pp. 387–404, 2017.
- [7] Kumar, N. M. G., Sangameswara Raju, P., Venkatesh, P. "Control of DC Capacitor Voltage in a DSTATCOM using Fuzzy Logic Controller", *International Journal of Advances in Engineering & Technology*, 4(1), pp. 679–690, 2012.
- [8] Kumar, K. S., Gopal, N. V. "Improvement of DC link voltage in D-Statcom based on Fuzzy logic", *The International Journal of Engineering and Science (IJES)*, 2(12), pp. 77–84, 2013.
- [9] Ghanmath, A. S., Vinayak, K. U. "Design and Simulation of DSTATCOM using Fuzzy Logic Controller", *International Research Journal of Engineering and Technology (IRJET)*, 8(1), pp. 157–163, 2021.
- [10] Aprem, A. A., Chacko, F. M. "Harmonic compensation using fuzzy controlled DSTATCOM", *International Journal of Engineering Research and General Science*, 3(5), pp. 1112–1129, 2015.
- [11] Mahmood, A. K., Ali, I. I., Al-Gailany, A. A. "Voltage stability improvements using adaptive controller for STATCOM", *Journal of Engineering and Sustainable Development*, 21(2), pp. 129–148, 2017.
- [12] Shi, J., Noshadi, A., Kalam, A., Shi, P. "Fuzzy logic control of DSTATCOM for improving power quality and dynamic performance", In: *2015 Australasian Universities Power Engineering Conference (AUPEC)*, Wollongong, NSW, Australia, 2015, pp. 1–6. ISBN 978-1-4799-8725-2 <https://doi.org/10.1109/AUPEC.2015.7324796>
- [13] Hamoodi, S. A., Hameed, F. I., Hamoodi, A. N. "Pitch Angle Control of Wind Turbine Using Adaptive Fuzzy-PID Controller", *EAI Endorsed Transactions on Energy Web*, 7(28), e15, 2020. <https://doi.org/10.4108/eai.13-7-2018.165500>
- [14] Zadeh, L. A. "The concept of a linguistic variable and its application to approximate reasoning—I", *Information Sciences*, 8(3), pp. 199–249, 1975. [https://doi.org/10.1016/0020-0255\(75\)90036-5](https://doi.org/10.1016/0020-0255(75)90036-5)
- [15] Hong, Y. Y., Hsieh, Y. L. "Interval Type-II Fuzzy Rule-Based STATCOM for Voltage Regulation in the Power System", *Energies*, 8(8), pp. 8908–8923, 2015. <https://doi.org/10.3390/en8088908>
- [16] Henini, N., Benzerafa, F., Tlemçani, A., Sebaa, K. "Type-1 and Type-2 Fuzzy Logic Controller Based Multilevel DSTATCOM Using SVM", *Studies in Informatics and Control*, 25(1), pp. 87–98, 2016. <https://doi.org/10.24846/v25i1y201610>
- [17] Hong, Y. Y., Nguyen, M. T. "Optimal design of IT2-FCS-based STATCOM controller applied to power system with wind farms using Taguchi method", *IET Generation, Transmission, & Distribution*, 12(13), pp. 3145–3151, 2018. <https://doi.org/10.1049/iet-gtd.2017.1236>
- [18] Vivekanand, G., Chandra Sekhar, K., Suresh, D. "Type2 Fuzzy Logic Controlled Adjustable Step-Size LMS Algorithm for DSTATCOM", *International Journal of Engineering & Technology*, 7(3.27), pp. 531–534, 2018. <https://doi.org/10.14419/ijet.v7i3.27.18487>
- [19] Hong, Y. Y., Liu, M. "Optimized Interval Type-II Fuzzy Controller-Based STATCOM for Voltage Regulation in Power Systems With Photovoltaic Farm", *IEEE Access*, 6, pp. 78731–78739, 2018. <https://doi.org/10.1109/ACCESS.2018.2885198>
- [20] Patel, J. B., Singh, A. "Modeling Analysis & Solution of Power Quality Problems Using DVR & DSTATCOM", *International Journal for Scientific Research & Development*, 1(5), pp. 1219–1224, 2013.
- [21] Liang, Q., Mendel, J. M. "Interval type2 fuzzy logic systems: theory and design", *IEEE Transactions on Fuzzy Systems*, 8(5), pp. 535–550, 2000. <https://doi.org/10.1109/91.873577>
- [22] Mendel, J. M., John, R. I. B. "Type-2 fuzzy sets made simple", *IEEE Transactions on Fuzzy Systems*, 10(2), pp. 117–127, 2002. <https://doi.org/10.1109/91.995115>
- [23] Mendel, J. M. "Uncertain Rule-Based Fuzzy Logic Systems: Introduction and New Directions", Prentice Hall PTR, 2001. ISBN 0-13-040969-3
- [24] Singh, B., Murthy, S. S., Gupta, S. "Analysis and design of STATCOM-based voltage regulator for self-excited induction generators", *IEEE Transactions on Energy Conversion*, 19(4), pp. 783–790, 2004. <https://doi.org/10.1109/TEC.2004.827710>
- [25] Mohan, N., Undeland, T. M., Robbins, W. P. "Power Electronics: Converters, Applications, and Design", John Wiley, 1995. ISBN 0-471-58408-8
- [26] Larsen, E. V., Miller, N. W., Nilsson, S. L., Lindgren, S. R. "Benefits of GTO-based compensation systems for electric utility applications", *IEEE Transactions on Power Delivery*, 7(4), pp. 2056–2064, 1992. <https://doi.org/10.1109/61.157009>
- [27] Institute of Electrical and Electronics Engineers "IEEE 519-2014 IEEE Recommended Practice and Requirements for Harmonic Control in Electric Power Systems", Institute of Electrical and Electronics Engineers, Piscataway, NJ, USA, 2014.