

# Multiplicative Multiresolution Decomposition for Lossless Volumetric Medical Images Compression

Leila Belhadef<sup>1\*</sup>, Meriem Outtas<sup>2</sup>, Zoulikha Mekakia Maaza<sup>1</sup>, Olivier Déforges<sup>2</sup>, Amina Serir<sup>3</sup>

<sup>1</sup> Laboratoire SIMPA, Faculté des Mathématiques et d'Informatique, Université des Sciences et de la Technologie d'Oran Mohamed Boudiaf, USTO-MB, P. O. B. 1505, El Mnaouer, Oran 31000, Algeria

<sup>2</sup> Institut National des Sciences Appliquées Rennes, CNRS, Institut d'Électronique et de Télécommunication de Rennes, UMR 6164, F-35000 Rennes, France

<sup>3</sup> Laboratory of Image Processing and Radiation, Faculty of Electronic and Computing, Université des Sciences et de la Technologie Houari Boumedienne, P. O. B. 32, El Alia Bab Ezzouar, Algiers 16111, Algeria

\* Corresponding author, e-mail: [leila.belhadef@univ-usto.dz](mailto:leila.belhadef@univ-usto.dz)

Received: 31 March 2022, Accepted: 17 August 2022, Published online: 01 September 2022

## Abstract

With the emergence of medical imaging, the compression of volumetric medical images is essential. For this purpose, we propose a novel Multiplicative Multiresolution Decomposition (MMD) wavelet coding scheme for lossless compression of volumetric medical images. The MMD is used in speckle reduction technique but offers some proprieties which can be exploited in compression. Thus, as the wavelet transform the MMD provides a hierarchical representation and offers a possibility to realize lossless compression. We integrate in proposed scheme an inter slice filter based on wavelet transform and motion compensation to reduce data energy efficiently. We compare lossless results of classical wavelet coders such as 3D SPIHT and JP3D to the proposed scheme. This scheme incorporates MMD in lossless compression technique by applying MMD/wavelet or MMD transform to each slice, after inter slice filter is employed and the resulting sub-bands are coded by the 3D zero-tree algorithm SPIHT. Lossless experimental results show that the proposed scheme with the MMD can achieve lowest bit rates compared to 3D SPIHT and JP3D.

## Keywords

volumetric medical images, lossless compression, motion compensation, wavelet transform, MMD

## 1 Introduction

The volumetric medical images are actually the most data used for diagnostic requirements. However, these images represent a big data for storing and viewing, thus numbers of methods have been developed to reduce size of volumetric medical images in the aim to overcome limited networking bandwidth and huge space for storage requirements.

Most of compression approaches of volumetric medical images are based on methods used in 2D images compression and videos compression to efficiently reduce data size. There are techniques that compress separately each slice by using 2D coders [1, 2].

However, the recent compression techniques of 3D/4D medical images exploit the redundancies in all dimensions. To be efficient to exploit the redundancies in inter slice direction ( $z$ ) and/or in temporal direction, these approaches fall into one of three categories: approaches based wavelet transform, approaches based motion compensation and approaches based motion compensated temporal filtering (MCTF).

The approaches based wavelet transform are efficient in reducing the redundancies in all dimensions and providing reversible compression, this permits lossless and lossy compression.

The presented works in [3, 4] are based on 3D integer wavelets transforms, where in [3] the 3D integer wavelet transform performs in spatial direction  $x$ ,  $y$  and  $z$ , after the resulting sub-bands are coded by 3D Embedded Zerotree Wavelet (3D EZW), the coder outperforms 2D coders by exploiting third dimension in lossless compression and also offers good performance in lossy compression. Although the work presented in [4] uses the 3D integer wavelet packet transform and the obtained sub-bands are coded with 3D Set Partitioning in Hierarchical Trees (3D SPIHT), this coder outperforms 2D coders and 3D EZW in lossless compression.

Actually, the reference for the compression of volumetric medical image is the wavelet coder JP3D [5]. It is an extension of the JPEG2000 standard [6]. In lossless compression

JP3D uses 3D integer wavelet transform in spatial axis  $x$ ,  $y$  and  $z$ , and codes the resulting wavelet coefficients by context models: the Embedded Block Coding by Optimized Truncation (EBCOT) [7]. In literature some works are proposed to improve JP3D compression for medical images, as in [8] the authors propose to include existing coding modes to JP3D such as an intra-band prediction mode.

Several techniques use the motion compensation for 3D/4D medical images have been published. The coder of 3D medical images presented in [9] is based on motion compensation and SPIHT, where the motion compensation is block based approach and performs in inter slice direction of 3D image, after each reference and residuals slices are decorrelated by 2D wavelet transform and coefficients are coded by 2D SPIHT, this technique outperforms JPEG-LS coder in lossy and lossless compression.

The scheme presented in [10] is based on 3D motion compensation in temporal direction of 4D medical images followed by the 3D integer wavelet transforms and 3D SPIHT. This scheme permits lossy to lossless coding.

Based on H.264/AVC video coding the authors of [11] present two approaches: the first uses multi-frame motion compensation in  $z$  direction to eliminate efficiently the similarity between slices composed the volume, the second uses multi-frame motion compensation in time direction. The two approaches are efficient and the best result is achieved with the second approach.

The same authors of precedent work propose new extension of their method [12]. The new is to use multi-frame motion compensation in  $z$  and temporal dimensions to exploit redundancies in all four dimensions [12]. This method achieves an improvement compared to H.264/AVC and JPEG2000.

The High Efficiency video coding (HEVC) is the video coding standard [13] used for both video and image compression. The standard is block based coding structure, the blocks are intra coded to exploit spatial redundancy of pixels and/or inter coded to exploit temporal redundancy of picture, HEVC is similar to H.264 but permits to achieve high compression ratio by using more precise coding tools such as large rang of block size. The coder offers also lossless mode to compress 3D medical images [14].

The motion compensation can also perform at the same time with the wavelet transform as in the video wavelet coding to eliminate redundancy efficiently in volumetric images, this filter is MCTF. The first works in video coding introduced MCTF was based on the Haar filter [15, 16]. With emergence of the lifting scheme to calculate wavelet

coefficients, the authors of [17] propose two motion compensated lifting schemes with the Haar lifting filter and the 5/3 lifting filter, the results show that the motion compensated 5/3 lifting filter outperforms the motion compensated Haar lifting filter. The work presented in [18] applies the motion compensation truncated 5/3 lifting filter which consists to realize only prediction step of lifting scheme this permit to reduce signal energy efficiently.

To obtain a temporal scalable representation of 4D medical image and improve compression results the MCTF is employed. Thus, the work presented in [19] uses the MCTF technique based on mesh compensation wavelet lifting. In [20] the Graph-based motion compensation wavelet lifting is applied the results show this approach can outperform block and mesh approach in lossy compression.

The works presented in [21, 22] are block based approaches, these approaches apply two different filters with different prediction techniques for lossless compression, the filters are truncated filters and perform in temporal direction after spatial decorrelation. These filters permit to achieve better lossless compression bit rates compared to approaches based on motion compensation or wavelet transform in inter slice direction.

All precedent cited techniques use in vertical and horizontal direction: wavelet transform or Discrete Cosine Transform (DCT).

In this paper we propose to integrate the MMD in compression process to demonstrate it efficiently to reduce data size. The MMD gives good results as blur reducing method for 2D images [23], and as images speckle reducing method for ultrasound medical images [24], although this decomposition is reversible [25] and can even be used in image compression. Also, we propose to integrate in compression scheme the proposed filter in [22]. This filter is based on the motion compensation and the 5/3 truncated lifting filtering, in the following we call it MC\_5/3 filter.

We compare lossless compression results of JP3D with approaches based on different configuration of the spatial filtering ( $x$ ,  $y$ ): approaches based on the wavelet transform (the WT techniques), approaches based on the MMD and the wavelet transform (the MMD\_WT techniques) and approach based on the MMD (the MMD technique). In inter slice direction, either MC\_5/3 filter performs or 1D 5/3 integer wavelet filter.

The WT technique WT\_3D-SPIHT is based on 3D integer wavelet transform and 3D SPIHT coding [26]; this is also reference compression technique of the 3D medical images used to evaluate the performance of the presented

techniques in this work. The second WT technique WT<sub>MC\_5/3</sub> uses 2D integer wavelet transform in  $(x, y)$  directions followed by the MC<sub>5/3</sub> filter in  $z$  direction, the sub-band results are coded with 3D SPIHT.

The MMD\_WT techniques: MMD1\_3D-SPIHT and MMD1\_MC\_5/3 apply 1D MMD in  $x$  direction followed by 1D integer wavelet transform in  $y$  direction. In inter slice direction the MMD1\_3D-SPIHT applies 1D integer wavelet transform 5/3 while the MMD1\_MC\_5/3 technique applies the MC<sub>5/3</sub> filter. The obtained sub-bands for both are coded with 3D SPIHT.

Through the MMD technique: MMD2\_MC\_5/3 after applying spatial decomposition of each slice with 2D MMD the MC<sub>5/3</sub> filter performs in inter slice direction, and also the sub-band results are coded with 3D SPIHT.

The approaches using MMD permit a lossless improvement compared with the classic approach such as 3D SPIHT and JP3D.

The paper is organized as follows. In the next section the 2D integer wavelet transform and the 2D MMD are presented. In Section 3 the proposed compression technique is introduced, the lossless compression results of volumetric medical images are discussed in Section 4. Our conclusion is followed in the final section.

## 2 Spatial decompositions

The proposed compression approaches use the 5/3 integer wavelet transform or the MMD in spatial direction  $(x, y)$ . The wavelet transform and the MMD produce a hierarchical representation by applying successive levels of decomposition along horizontal and vertical axis of the image, this representation permits to create a low sub-band (approximation of the image) and high sub-bands (details) (Fig. 1).

### 2.1 The 5/3 integer wavelet transform

The 5/3 integer wavelet transform is realized by lifting scheme which consists in three steps split, predict and update [27]. Thus, the input signal  $x[n]$  is splitting in two samples even  $x[2n]$  and odd  $x[2n + 1]$ , after predict and update steps are applied as following:

$$H[2n+1] = x[2n+1] - \left\lfloor \frac{x[2n] + x[2n+2]}{2} \right\rfloor, \quad (1)$$

$$L[2n] = x[2n] + \left\lfloor \frac{H[2n-1] + H[2n+1]}{4} \right\rfloor, \quad (2)$$

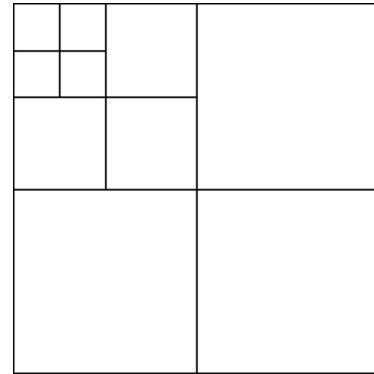

Fig. 1 Representation of 2D three decomposition levels

where  $\lfloor \cdot \rfloor$ : corresponds to round operators,  $H$  is high frequency coefficients and  $L$  is low frequency coefficients. In first level the three steps of lifting perform first in horizontal direction of the image, the obtained coefficients are vertically filtered to produce one low frequency and three high frequency sub-bands. In the next level the three steps of lifting are applied to low frequency sub-band in horizontal and vertical directions. Thus, this process is repeated until the given level. These obtained low frequency sub-band and high frequency sub-bands permit to reconstruct the original image by reversing steps of lifting. The lifting scheme generates integer coefficients that allow lossless compression.

### 2.2 The MMD

As wavelet transform, the MMD [23–25] is considered as successive levels of decomposition. In level one each two samples of input signal represent two polyphase components.

The polyphase components of input signal  $x[n]$  are defined as followed:

$$x_i[n] = x[2(n-1) + i] \quad \forall i \in \{1, 2\}. \quad (3)$$

Two pairs of filters are used for analysis and synthesis  $(\{h_i\}, D)$  and  $(\{f_i\}, R)$  respectively [24]. This system of analysis and synthesis permits the perfect reconstruction  $\hat{x}_i = x_i$ .

The linear analysis filter  $h_i$  and the linear synthesis filter  $f_i$  are defined as followed:

$$h_i[k] = h[2(k-1) + i] \quad \forall i \in \{1, 2\}, \quad (4)$$

$$f_i[k] = f[2(k-1) + i] \quad \forall i \in \{1, 2\}, \quad (5)$$

with:

$$f_i[k] = h_i^{-1}[k] \quad \forall i \in \{1, 2\}. \quad (6)$$

The linear analysis filter  $h_i$  permits to obtain the low frequency coefficients  $Y1$ .

In compression, before the application of the linear analysis filter  $h_i$ , all pixels are amplified with positive scalar  $C1$  to calculate high frequency coefficients (Fig. 2).

The high frequency coefficients are calculated with the nonlinear analyses filter  $D$  as following:

$$Y2 = \begin{cases} \beta \frac{x'_2}{x'_1}, & x'_1 \geq x'_2 \\ \beta \left( 2 - \frac{x'_1}{x'_2} \right), & x'_1 < x'_2 \end{cases}, \quad (7)$$

where:

$$x'_i = x_i + C1 \quad \forall i \in \{1, 2\}, \quad (8)$$

with  $\beta$  is a positive scalar.

The homogeneous regions are numerous in medical images, these regions are characterized by high frequency coefficient values  $Y2$  identical to  $\beta$ , thus in our compression scheme  $\beta$  value is deducted from the high frequency coefficients value in the aim to obtain more zero coefficients in high frequency sub-bands. The resulting high frequency coefficients different than zero have small real values, in the aim to conserve these values in compression, they are multiplied by positive scalar  $C2$ . In final we obtain the high frequency coefficients  $Y'2$  as following:

$$Y'2 = \lfloor (Y2 - \beta) \times C2 - \alpha \rfloor, \quad (9)$$

where  $\alpha$  value represents the smallest value of  $((Y2 - \beta) \times C2)$  obtained when  $Y2 > \beta$  and  $x'_2 - x'_1 = 1$  this permits to obtain more zero coefficients in high frequency sub-bands.

For not to penalize the compression scheme after calculating high frequency coefficients  $Y'2$ , the low frequency coefficients are used in next step without coefficient  $C1$  (Fig. 2).

To reconstruct the original image (Fig. 3) the nonlinear synthesis filter  $R$  is defined as following:

$$r_1(Y2) = \frac{1}{1 + \frac{x'_2}{x'_1}}, \quad (10)$$

$$r_2(Y2) = \frac{x'_2}{x'_1} r_1(Y2). \quad (11)$$

In first level the 1D MMD is applied first along horizontal direction of the image, the obtained coefficients are vertically filtered to produce one low frequency sub-band ( $Y1$ ) and three high frequency sub-bands ( $Y2$ ).

The Fig. 2 describes 1D MMD analysis filter, therefore to calculate the low and the high sub-bands in next step, each two coefficients of  $Y1$  are considered as two polyphase components.

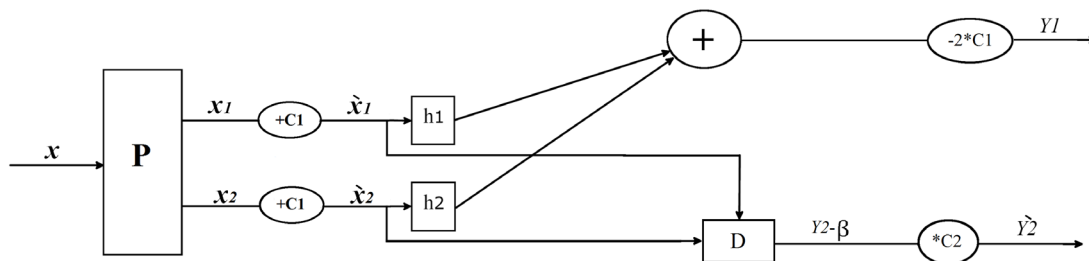

Fig. 2 Representation of 1D MMD for decomposition (Analysis)

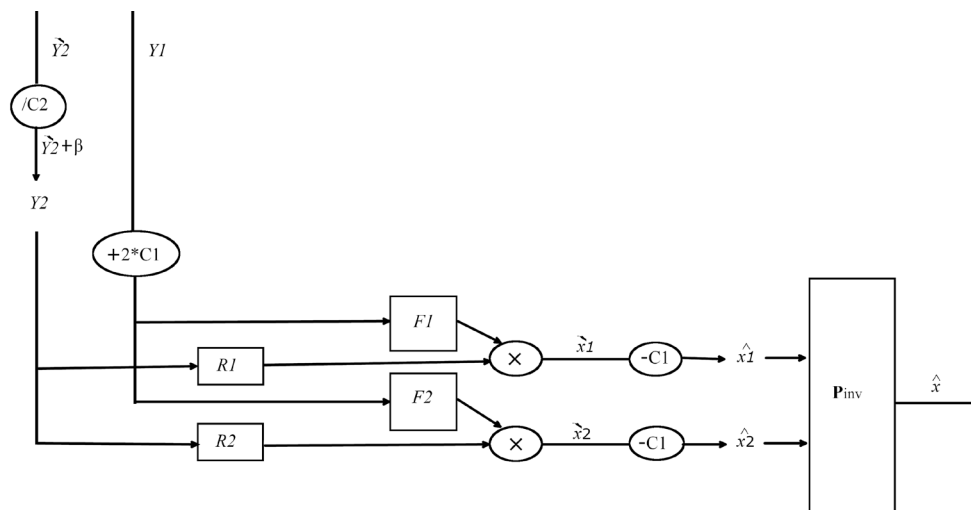

Fig. 3 Representation of 1D MMD for reconstruction (Synthesis)

### 3 The proposed volumetric image compression techniques

We present three techniques of compression by using the MMD in compression scheme based wavelet: MMD1\_MC\_5/3, MMD2\_MC\_5/3 and MMD1\_3D-SPIHT approaches.

The MMD1\_MC\_5/3 approach has the following pseudo-code (Algorithm 1).

All MMD approaches use the same step of Algorithm 1 by using different filters or decomposition in three directions. The 3D image is represented by a set of groups of slices (GOS) composed of  $M$  consecutive slices in  $z$  direction (Step 2). After the spatial decorrelation is applied in  $x, y$  directions for each slice composed GOS by using 2D spatial transform (Fig. 4).

The MMD1\_MC\_5/3 and the MMD1\_3D-SPIHT approaches use 1D MMD in  $x$  direction followed by 1D integer wavelet transform 5/3 in  $y$  direction (Step 3). However, the MMD2\_MC\_5/3 approach uses 2D MMD in  $x, y$  directions.

The obtained sub-bands are filtered in  $z$  direction; the MMD1\_3D-SPIHT approach applies 1D integer wavelet transform 5/3. However, the MMD1\_MC\_5/3 and the MMD2\_MC\_5/3 approaches use MC\_5/3 filter (step 4).

The MC\_5/3 filter applies different prediction techniques to reduce energy of obtained sub-bands, thus each inter slice (to be predicted) is divided in blocks and each block is either unfiltered or filtered by one of following

---

#### Algorithm 1 Pseudo-code of the MMD1\_MC\_5/3 approach

---

**Input:** 3D medical image ( $X$ )  
**Output:** Compressed bit stream  
**Step 1:**  $[x, y, z] = \text{size}(X)$   
**Step 2:** Each  $M$  consecutive slices represent GOS  
 $z1$  first slice of GOS  
 $z2 = z1 + M - 1$   
**Step 3:**  $L$  levels of spatial decomposition  
 for level = 1 to  $L$   
 for  $z1$  to  $z2 + 1$   
 1D MMD in  $x$  direction  
 1D integer wavelet transform 5/3 in  $y$  direction  
 end for  
 $x \leftarrow x/2$   
 $y \leftarrow y/2$   
 end for  
 /\*  $z2 + 1$  represents first slice of next GOS used in MC\_5/3 filter\*/  
**Step 4:** Inter slice filtering  
 for level = 1 to  $L$   
 MC\_5/3 filter in  $z$  direction of GOS  
 end for  
**Step 5:** Coding of sub-bands, motion vectors and etiquettes  
 Sub-bands coding with 3D SPIHT and arithmetic coder  
 Motion vectors and etiquettes coding with arithmetic coder  
**Step 6:** Repeat from step 2 until all GOS are coded.

---

prediction techniques: the truncated 5/3 lifting transform (only prediction step of lifting scheme is used) or the motion compensation (Fig. 5).

The motion compensation is realized by block matching with full search method using variable search windows size (the size increase in next level of decomposition)

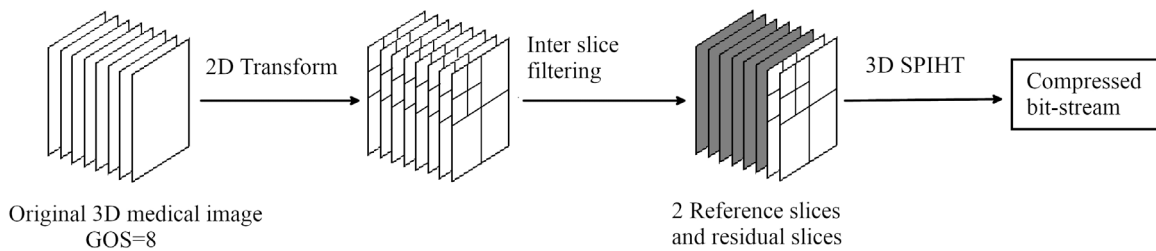

Fig. 4 Compression scheme with 2 levels of decomposition of spatial transform (MMD or WT) and inter slice filtering (MC\_5/3 or 5/3 wavelet filter)

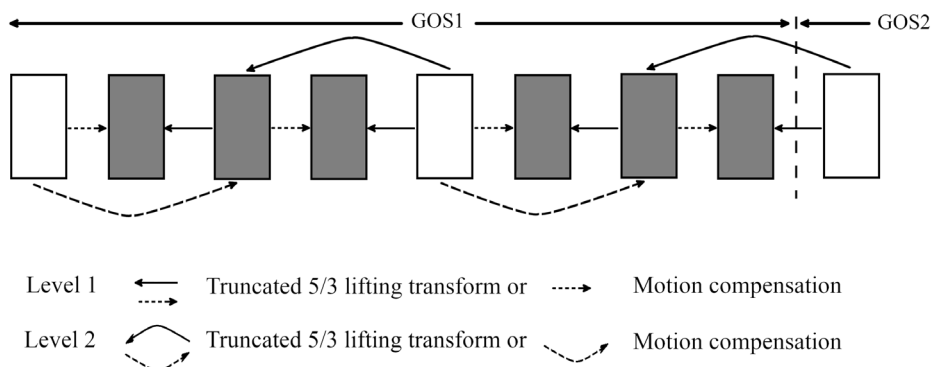

Fig. 5 The MC\_5/3 filter with two levels of decomposition for GOS composed by 8 slices



and blocks size of  $16 \times 16$  pixels. The residual block represents difference between inter block and its most similar reference block in search windows, which is localized by motion vectors.

The MC\_5/3 filter can be represented by three prediction errors:

The unfiltered block  $B[m, n]$ :

$$E_1[m, n] = B[m, n]. \quad (12)$$

The truncated 5/3 lifting transform (without motion compensation):

$$E_2[m, n] = B[m, n] - \left\lfloor \frac{A[m, n] + C[m, n]}{2} \right\rfloor. \quad (13)$$

The motion compensated prediction:

$$E_3[m, n] = B[m, n] - A[m - d_m, n - d_n], \quad (14)$$

where:

$A, C$ : reference slices, and  $B$ : inter slice;

$E_1[m, n], E_2[m, n], E_3[m, n]$ : residual blocks;

$(d_m, d_n)$ : motion vector of block  $B[m, n]$  to a position in  $A$ .

The minimum is chosen among the three prediction errors in order to determine the prediction error of the block  $B[m, n]$  and its prediction method. The residual blocks compose residual slices thus each inter slice can be reconstructed by corresponding residual slice and its corresponding motion fields and/or etiquettes [22].

The two approaches the MMD1\_MC\_5/3 and the MMD2\_MC\_5/3 apply the MC\_5/3 filter to each GOS. The last slice (Fig. 5) is the first reference slice in following GOS.

After inter slice filtering the obtained GOSs are coded by 3D SPIHT [26] for the all MMD approaches.

3D SPIHT is used to determine the zero trees by exploiting the inter dependence between coefficients in three dimensions  $x, y$  and inter slices. Therefore, if coefficients in lowest frequency sub-bands are insignificant, then probably all its descendants are insignificant in high frequency sub-bands. Locating these zero trees in each bit plane permits to reduce data size, the result bit stream is coded by arithmetic coder. For the MMD1\_MC\_5/3 and the MMD2\_MC\_5/3 approaches the motion vectors and etiquettes are also coded by arithmetic coder.

#### 4 Experimental results

In this section, we present the lossless experimental results on the proposed MMD methods for compression of 3D medical images.

We used three 3D test images generated by Computer Tomography (CT) and three 3D test images generated by Magnetic Resonance (MR) [28] as presented in Fig. 6.

All tested images are 8 bits pixels value. Each one is composed of a set of slices; the size of each tested image is presented in Table 1.

We use two different size GOS's 8 and 16 to test volumetric images for 2 and 3 levels of decomposition, respectively, in  $x, y$  and inter slice directions.

The proposed approaches are compared to WT\_3D-SPIHT, WT\_MC\_5/3 and JP3D. The WT\_3D-SPIHT and the WT\_MC\_5/3 represent 3D image with GOS (GOS = 8 or GOS = 16). In the WT\_3D-SPIHT 3D integer wavelet transform 5/3 is performed in each GOS and in the WT\_MC\_5/3 2D integer wavelet transform 5/3 is applied on each slice, followed by MC\_5/3 filter in inter slice direction. The obtained sub-bands are coded with 3D SPIHT for both approaches.

JP3D uses 3D integer wavelet transform 5/3 in spatial axis  $x, y$  and  $z$  of 3D image, the resulting wavelet coefficients are partitioned into rectangular blocks, which are coded separately by use of 3D context models EBCOT.

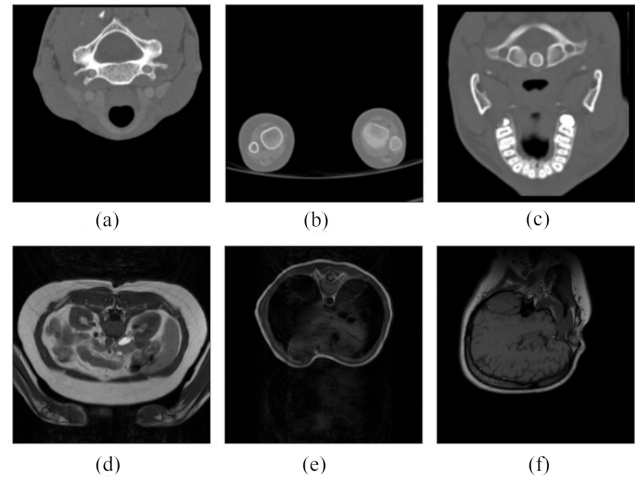

Fig. 6 First slice of each 3D test image: (a) CT\_carotid, (b) CT\_aperts, (c) CT\_skull, (d) MR\_liver\_t1, (e) MR\_ped\_chest, (f) MR\_sag\_head

Table 1 3D medical images used for experiments

Name	Volume Size
CT_carotid	$256 \times 256 \times 64$
CT_aperts	$256 \times 256 \times 96$
CT_skull	$256 \times 256 \times 192$
MR_liver_t1	$256 \times 256 \times 48$
MR_ped_chest	$256 \times 256 \times 64$
MR_sag_head	$256 \times 256 \times 48$

In MMD schemes the MMD coefficients  $C1$  and  $C2$  are determined in the aim to obtain lossless compression with lower bit rates, indeed the MMD coefficient values influence the obtained bit rates, in this test  $\beta = 1.0$  and  $C1 = 50000$  for all levels of decomposition and values of  $C2$  are presented in Table 2. After each application of 1D MMD filter the value of low-pass MMD coefficients increase, so to obtain lossless compression with the same value of  $C1$  the value of  $C2$  increase too for all MMD techniques after each 1D MMD filter.

The lossless compression bit rates are shown in Table 3 and Table 4. The columns 2, 3 and 4 list the bit rates obtained by proposed MMD schemes. The columns 5 and 6 list the bit rates obtained by wavelet schemes. The latter is lossless implementation of JP3D version 2.4.0 [29].

Table 3 shows that using MC\_5/3 filter in MMD1\_MC\_5/3 and WT\_MC\_5/3 approaches permits superior results compared to all others approaches with 2 levels of decomposition. Also the obtained bit rates of MR\_ped\_chest and MR\_sag\_head using MMD2\_MC\_5/3 achieve an improvement compared to JP3D.

However, we observe in Table 4 GOS of 16 gives better compression performance. Also, 3 decomposition levels out performs smaller decomposition in all cases.

**Table 2**  $C2$  values used in MMD techniques for lossless compression

Filter	MMD1	MMD2	
Axis	$x$	$x$	$y$
$C2$ , level1	25200	25200	25400
$C2$ , level2	25400	25800	26600
$C2$ , level3	25800	28200	30400

**Table 3** Average bit rate in bpp for lossless compression with 2 levels of decomposition (GOS = 8)

Technique	MMD1_3D-SPIHT	MMD1_MC_5/3	MMD2_MC_5/3	WT_3D-SPIHT	WT_MC_5/3	JP3D
CT_carotid	1.743	1.649	1.782	1.629	<b>1.553</b>	1.633
CT_aperts	1.171	1.080	1.175	1.084	<b>1.019</b>	1.123
CT_skull	2.498	2.231	2.325	2.414	<b>2.164</b>	2.321
MR_liver_t1	2.815	2.528	2.721	2.642	<b>2.403</b>	2.594
MR_ped_chest	2.339	<b>2.079</b>	2.176	2.329	2.096	2.318
MR_sag_head	2.498	<b>2.299</b>	2.344	2.528	2.33	2.481

**Table 4** Average bit rate in bpp for lossless compression with 3 levels of decomposition (GOS = 16)

Technique	MMD1_3D-SPIHT	MMD1_MC_5/3	MMD2_MC_5/3	WT_3D-SPIHT	WT_MC_5/3	JP3D
CT_carotid	1.682	1.616	1.747	1.58	1.53	<b>1.507</b>
CT_aperts	1.116	1.044	1.138	1.041	0.996	<b>0.944</b>
CT_skull	2.404	2.186	2.282	2.333	<b>2.126</b>	2.144
MR_liver_t1	2.689	2.456	2.641	2.544	<b>2.352</b>	2.407
MR_ped_chest	2.245	<b>1.974</b>	2.051	2.264	2.014	2.052
MR_sag_head	2.407	2.271	2.312	2.459	2.326	<b>2.19</b>

The results of CT images in Table 4 show the bit rates obtained by WT\_MC\_5/3 and JP3D outperform all the other techniques. However, with image test CT\_skull the MMD1\_MC\_5/3 technique achieves nearest result to the last two cited techniques with difference around 2% to 3%.

With image test MR\_liver\_t1 the WT\_MC\_5/3 technique permits an improvement compared to the other techniques.

With test image MR\_ped\_chest the superior result is obtained by the MMD1\_MC\_5/3 technique with little improvement compared to the WT\_MC\_5/3 technique 1.98% and JP3D 3.8%. We note the MMD2\_MC\_5/3 technique achieves the same result to JP3D.

With the last test image MR\_sag\_head the JP3D outperforms all other techniques followed by two MMD techniques (MMD1\_MC\_5/3, MMD2\_MC\_5/3) and WT\_MC\_5/3 technique.

The use of the MC\_5/3 filter permits to obtain a good bit rates in both compression schemes WT and MMD for all images test compared to the same schemes without the MC\_5/3 filter: the MMD1\_3D-SPIHT and WT\_3D-SPIHT. The MC\_5/3 filter is more efficient to take advantage of inter slice correlation in compression schemes WT and MMD.

## 5 Conclusions

We proposed a lossless compression technique for volumetric medical images. Our technique integrates MMD filter in wavelet compression scheme. The proposed method applies 1D MMD/1D WT or 2D MMD to each slice composed GOS followed by inter slice filter based on wavelet transform and motion compensation. The coefficients of transformed GOS are coded by 3D SPIHT algorithm.

Experimental results show that the proposed scheme can achieve lowest bit rates compared with the classical wavelet approach such as 3D SPIHT and JP3D.

## References

- [1] Weinberger, M. J., Seroussi, G., Sapiro, G. "LOCO-I: A low complexity, context-based lossless image compression algorithm", In: Proceedings of Data Compression Conference - DCC '96, Snowbird, UT, USA, 1996, pp. 140–149. ISBN 0-8186-7358-3  
<https://doi.org/10.1109/DCC.1996.488319>
- [2] Wu, X., Memon, N. "Context based, adaptive, lossless image coding", IEEE Transactions on Communications, 45(4), pp. 437–444, 1997.  
<https://doi.org/10.1109/26.585919>
- [3] Bilgin, A., Zweig, G., Marcellin, M. W. "Efficient lossless coding of medical image volumes using reversible integer wavelet transforms", In: Proceedings DCC '98 Data Compression Conference, Snowbird, UT, USA, 1998, pp. 428–437. ISBN 0-8186-8406-2  
<https://doi.org/10.1109/DCC.1998.672188>
- [4] Kim, Y.-S., Pearlman, W. A. "Lossless Volumetric Medical Image Compression", In: Proceedings of SPIE's International Symposium on Optical Science, Engineering, and Instrumentation, Denver, CO, USA, 1999, pp. 305–312. ISBN 9780819432940  
<https://doi.org/10.1117/12.365842>
- [5] ISO "ISO/IEC (15444-10) Information Technology - JPEG 2000 Image Coding System: Part 10 - Extensions for Three-Dimensional Data (JP3D)", International Organization for Standardization, Geneva, Switzerland, 2007.
- [6] Skodras, A. N., Ebrahimi, T. "JPEG2000 Image Coding System Theory and Applications", In: 2006 IEEE International Symposium on Circuits and Systems, Kos, Greece, 2006, pp. 3866–3869. ISBN 0-7803-9389-9  
<https://doi.org/10.1109/ISCAS.2006.1693472>
- [7] Bruylants, T., Alecu, A., Kimpe, T., Deklerck, R., Munteanu, A., Schelkens, P. "An optimized 3D context model for JPEG2000 Part 10", In: SPIE Medical Imaging 2007: Image Processing, San Diego, CA, USA, 2007, 65124K. ISBN 9780819466303  
<https://doi.org/10.1117/12.709170>
- [8] Bruylants, T., Munteanu, A., Schelkens, P. "Wavelet based volumetric medical image compression", Signal Processing: Image Communication, 31, pp. 112–133, 2015.  
<https://doi.org/10.1016/j.image.2014.12.007>
- [9] Ferni Ukrit, M., Suresh, G. R. "Motion estimation and motion compensated medical image sequence compression using SPIHT", In: 2013 Fifth International Conference on Advanced Computing (ICoAC), Chennai, India, 2013, pp. 258–262. ISBN 978-1-4799-3448-5  
<https://doi.org/10.1109/ICOAC.2013.6921960>
- [10] Kassim, A. A., Yan, P., Lee, W. S., Sengupta, K. "Motion Compensated Lossy-to-Lossless Compression of 4D Medical Images Using Integer Wavelet Transforms", IEEE Transactions Information Technology in Biomedicine, 9(1), pp. 132–138, 2005.  
<https://doi.org/10.1109/TITB.2004.838376>
- [11] Sanchez, V., Nasiopoulos, P., Abugharbieh, R. "Lossless Compression of 4D Medical Images using H.264/AVC", In: IEEE International Conference on Acoustics, Speech, and Signal Processing, Toulouse, France, 2006, pp. 1116–1119. ISBN 1-4244-0469-X  
<https://doi.org/10.1109/ICASSP.2006.1660543>
- [12] Sanchez, V., Nasiopoulos, P., Abugharbieh, R. "Efficient 4D motion compensated lossless compression of dynamic volumetric medical image data", In: 2008 IEEE International Conference on Acoustics, Speech and Signal Processing, Las Vegas, NV, USA, 2008, pp. 549–552. ISBN 978-1-4244-1483-3  
<https://doi.org/10.1109/ICASSP.2008.4517668>
- [13] Sullivan, G. J., Ohm, J.-R., Han, W.-J., Wiegand, T. "Overview of the High Efficiency Video Coding (HEVC) Standard", IEEE Transactions on Circuits and Systems for Video Technology, 22(12), pp. 1649–1668, 2012.  
<https://doi.org/10.1109/TCSVT.2012.2221191>
- [14] Parikh, S. S., Ruiz, D., Kalva, H., Fernandez-Escribano, G., Adzic, V. "High Bit-Depth Medical Image Compression with HEVC", IEEE Journal of Biomedical and Health Informatics, 22(2), pp. 552–560, 2018.  
<https://doi.org/10.1109/JBHI.2017.2660482>
- [15] Ohm, J.-R. "Three-dimensional subband coding with motion compensation", IEEE Transactions on Image Processing, 3(5), pp. 559–571, 1994.  
<https://doi.org/10.1109/83.334985>
- [16] Choi, S.-J., Woods, J. W. "Motion-compensated 3-d subband coding of video", IEEE Transactions on Image Processing, 8(2), pp. 155–167, 1999.  
<https://doi.org/10.1109/83.743851>
- [17] Secker, A., Taubman, D. "Motion-compensated highly scalable video compression using an adaptive 3d wavelet transform based on lifting", In: Proceedings 2001 International Conference on Image Processing, Thessaloniki, Greece, 2001, pp. 1029–1032. ISBN 0-7803-6725-1  
<https://doi.org/10.1109/ICIP.2001.958672>
- [18] Luo, L., Li, J., Li, S., Zhuang, Z., Zhang, Y.-Q. "Motion compensated lifting wavelet and its application in video coding", In: IEEE International Conference on Multimedia and Expo, Tokyo, Japan, 2001, pp. 365–368. ISBN 0-7695-1198-8  
<https://doi.org/10.1109/ICME.2001.1237732>
- [19] Schnurrer, W., Pallast, N., Richter, T., Kaup, A. "Temporal Scalability of Dynamic Volume Data Using Mesh Compensated Wavelet Lifting", IEEE Transactions on Image Processing, 27(1), pp. 419–431, 2018.  
<https://doi.org/10.1109/TIP.2017.2762586>

## Acknowledgement

This research was supported by the Algerian Ministry of Higher Education and Scientific Research, General Direction of Scientific Research and Technological Development.



- [20] Lanz, D., Kaup, A. "Graph-Based Compensated Wavelet Lifting for Scalable Lossless Coding of Dynamic Medical Data", *IEEE Transactions on Image Processing*, 29, pp. 2439–2451, 2019. <https://doi.org/10.1109/TIP.2019.2947138>
- [21] Belhadef, L., Mekkakia Maaza, Z. "Lossless 4D Medical Images Compression with Motion Compensation and Lifting Wavelet Transform", *International Journal of Signal Processing Systems*, 4(2), pp. 168–171, 2016. <https://doi.org/10.12720/ijsp.4.2.168-171>
- [22] Belhadef, L., Mekkakia Maaza, Z. "Lossless 4D Medical Images Compression Using Adaptive Inter Slices Filtering", *International Journal of Advances in Applied Sciences*, 7(4), pp. 361–368, 2018. <https://doi.org/10.11591/ijaas.v7.i4.pp361-368>
- [23] Serir, A., Hamadene, A., Kerouh, F. "Blurreduction by a Multiplicative Multiresolution Decomposition MMD", In: *International Workshop on Systems, Signal Processing and their Applications*, Tipaza, Algeria, 2011, pp. 63–66. ISBN 978-1-4577-0690-5 <https://doi.org/10.1109/WOSSPA.2011.5931413>
- [24] Outtas, M., Zhang, L., Déforges, O., Serir, A., Hamidouche, W. "Filtre multi-sorties pour la réduction de bruit appliqué aux images médicales ultrasons" (Multi-Output Filter for Reduction of Speckle Noise in ultrasound Medical Images), In: *Compression et Représentation des Signaux Audiovisuels CORESA 2017*, Caen, France, 2017, hal-01809651. [online] Available at: <https://hal.archives-ouvertes.fr/hal-01809651/document> [Accessed: 10 May 2020] (in French)
- [25] Serir, A., Belouchrani, A. "Multiplicative multiresolution decomposition with perfect reconstruction", In: *Proceedings of the 3rd IEEE International Symposium on Signal Processing and Information Technology*, Darmstadt, Germany, 2003, pp. 30–33. ISBN 0-7803-8292-7 <https://doi.org/10.1109/ISSPIT.2003.1341052>
- [26] Kim, B.-J., Pearlman, W. A. "An Embedded Wavelet Video Coder Using Three-Dimensional Set Partitioning in Hierarchical Trees (SPIHT)", In: *Proceedings DCC '97. Data Compression Conference*, Snowbird, UT, USA, 1997, pp. 251–260. ISBN 0-8186-7761-9 <https://doi.org/10.1109/DCC.1997.582048>
- [27] Daubechies, I., Sweldens, W. "Factoring wavelet transforms into lifting steps", *Journal of Fourier Analysis and Applications*, 4, pp. 247–269, 1998. <https://doi.org/10.1007/BF02476026>
- [28] Rensselaer Polytechnic Institute "Center for Image Processing Research" [online] Available at: <http://www.cipr.rpi.edu/resource/sequences/> [Accessed: 05 June 2013]
- [29] Université de Louvain "OpenJPEG", [online] Available at: <https://www.openjpeg.org> [Accessed: 12 Mai 2021]