

## INVESTIGATION OF DUCTILE FRACTURE OF NANOSTRUCTURED AL-6082 MATERIAL

György KRÁLLICS\* and Ahmed S. M. AGENA\*\*

Department of Materials Science and Engineering,  
Budapest University of Technology and Economics,  
H-1111 Budapest, Bertalan L u.7.

\* Tel: (1) 463 1445,

\*e-mail: krallics@eik.bme.hu

\*\* Tel: (6) 70-502-9031,

e-mail: ahmedajina@yahoo.com

Received: Sept. 14, 2004

### Abstract

In this paper we are going to investigate the ductile fracture in cold forming of nanostructured Al - 6082 alloy material during axi-symmetric collar (flanged) tests and cylindrical upsetting tests by using eight types of fracture criteria. The material of specimens were taken out of ECAP was made by one, four, and eight passes (route C) in three perpendicular axes. The material has ultrafine grain size and an anisotropic behaviour. A simple yield criterion and material law are used to describe the plastic deformation of the nanostructured material. The collar tests and cylindrical upsetting tests produced typical ductile fractures in all types of specimens.

*Keywords:* nanostructured Al-6082 alloy, upsetting test, ductile fracture criteria.

### 1. Introduction

Most of previous studies have dealt with workability of isotropic materials which is easier to define by mechanical and physical properties. In recent years, bulk nanostructured materials (NSM) processed by several plastic deformations (SPD) have been investigated by a few literature and it is still limited.

Generally, nanostructured materials produced by (ECAP) process, the workability parameters depend on the number of passes, the type of route, and the direction of the specimen's axis and it refers to the relative ease with which the material can be shaped through plastic deformation and it is a function of the material and the process. A large number of tests are currently used to evaluate the ductility of nanostructured materials such as tension, torsion, and compression tests. The initiation of ductile fracture is a major factor influencing the limit of deformability in many metalworking operations [1]. In this work, several upsetting tests were carried out to evaluate the formability of nanostructured Al -6082 alloy by using cylindrical and flanged specimens (*Fig. 1*) and the flow curves for all types of specimens were plotted.

## 2. Ductile Fracture Criteria

Workability is usually thought as being limited by the onset of the fracture. Greater workability of the material allows greater deformation. In this study many types of ductile fracture criteria were used to determine the limit of the bulk deformation. The empirical formulas of these criteria are described below [2, 3, 4].

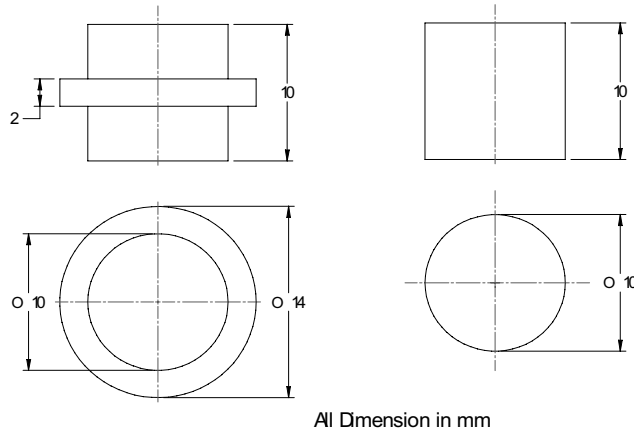

Fig. 1. Geometry of work piece (a) Flanged specimen (b) cylindrical specimen

### 2.1. Cockcroft and Latham Fracture Criterion

This criterion is based on true ductility and it is suggesting that the fracture occurs when the tensile strain energy reaches a critical value :

$$\frac{1}{\sigma_y} \int_0^{\bar{\epsilon}_f} \sigma_1 d\bar{\epsilon} = C_1 \quad (1)$$

where  $\sigma_1$  is the maximum tensile stress and  $\sigma_y$  is the yield stress.

### 2.2. Brozzo et al. Fracture Criterion

Brozzo et al. have made a modification to the *Cockcroft and Latham* criterion (Eq. (1)). This criterion depends on the maximum tensile stress  $\sigma_1$  and hydrostatic

(mean) stress  $\sigma_m$ :

$$\int_0^{\bar{\varepsilon}_f} \frac{2\sigma_1}{3(\sigma_1 - \sigma_m)} d\bar{\varepsilon} = C_2 \quad (2)$$

### 2.3. Freudenthal Fracture Criterion

It is assuming that the total plastic work to fracture is constant:

$$\frac{1}{\sigma_y} \int_0^{\bar{\varepsilon}_f} \bar{\sigma} d\bar{\varepsilon} = C_3 \quad (3)$$

where  $\bar{\sigma}$  is the effective stress,  $\bar{\varepsilon}$  is the effective strain at fracture and  $\sigma_y$  is the yield stress.

### 2.4. Im and Argan Fracture Criterion

This criterion assumes that the integration of the amount of hydrostatic stress and effective stress is constant:

$$\frac{1}{\sigma_y} \int_0^{\bar{\varepsilon}_f} (\sigma_m + \bar{\sigma}) d\bar{\varepsilon} = C_4 \quad (4)$$

### 2.5. Oyane et al. Fracture Criterion

This criterion assumes that the fracture occurs at a critical volumetric strain:

$$\int_0^{\bar{\varepsilon}_f} \left(1 + \frac{\sigma_m}{A\bar{\sigma}}\right) d\bar{\varepsilon} = C_5 \quad (5)$$

where  $A = 2/3$  (i.e. between uniaxial and triaxial stress states).

### 2.6. Oh and Kobayashi Criterion

It assumes that the ratio of the maximum tensile stress and effective strain is equal to constant:

$$\int_0^{\bar{\varepsilon}_f} \frac{\sigma_1}{\bar{\sigma}} d\bar{\varepsilon} = C_6 \quad (6)$$

### 2.7. Shabaic and Vujovic Criterion

This criterion considers the ratio of mean stress and effective stress and it gives the following fracture model:

$$\left( \frac{3\sigma_m}{\bar{\sigma}} \right) = C_7 \quad (7)$$

### 2.8. Tresca Energy Fracture Criterion

This is a simple criterion. Considering the difference between tensile and compression stresses, it is as follows:

$$\frac{1}{\sigma_y} \int_0^{\bar{\varepsilon}_f} \left( \frac{\sigma_1 - \sigma_2}{2} \right) d\bar{\varepsilon} = C_8 \quad (8)$$

where  $\sigma_1$  is the maximum tensile stress,  $\sigma_2$  is the maximum compression stress and  $\sigma_y$  is the yield stress.

$C_1, C_2, C_3, C_4, C_5, C_6, C_7$  and  $C_8$  are constants.

## 3. Calculation of Ductile Fracture Criterion Constants

In order to calculate ductile fracture criteria we need at least a certain kind of destructive test. In this work we carried out compression tests, and results were simulated using computer programme to determine anisotropic parameters. Each ductile fracture criterion needs to calculate stress state and effective stress.

#### 4. Theoretical Background

The continuum theory of plasticity (continuum mechanics) attempts to describe the stress –strain behaviour of a continuum on the basis of postulated yield criteria without regard to internal structure. Continuum mechanics also bypasses all of details involved in dislocation mechanics.

Mathematical modelling of bulk forming operation requires a yield criterion that describes the anisotropic yielding behaviour of the bulk metal.

Plasticity continuum theory was originally developed for an isotropic material. The theory was then modified by many anisotropic yield criteria such as: *Hill* criterion to explain the effects of anisotropy on the forming processes by incorporating the ‘parameters of anisotropic plasticity’ or the ‘coefficients of anisotropy’. HILL [13] extended the theoretical framework of Von Mises criterion to include anisotropy and expressed his criterion as:

$$F(\sigma_{22} - \sigma_{33})^2 + G(\sigma_{33} - \sigma_{11})^2 + H(\sigma_{11} - \sigma_{22})^2 + 2L\sigma_{23}^2 + 2M\sigma_{31}^2 + 2N\sigma_{12}^2 = 1 \quad (9)$$

where  $F, G, \dots, N$  are anisotropy parameters.

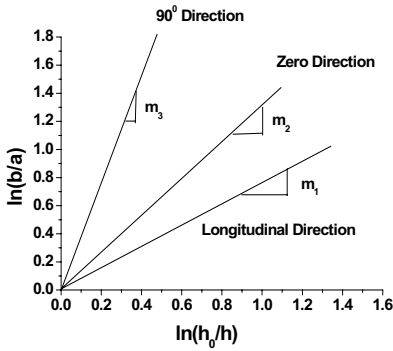

Fig. 2. Values of  $m_1, m_2$  and  $m_3$ .

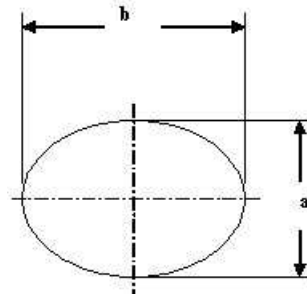

Fig. 3. Ellipse axes of deformed specimen

From this criterion the equivalent stress can be expressed as [8]:

$$\bar{\sigma}_{eq} = \left( \frac{\sqrt{3}}{2\sqrt{(FH+FG+GH)}} \left[ F(\sigma_{22} - \sigma_{33})^2 + G(\sigma_{33} - \sigma_{11})^2 + H(\sigma_{11} - \sigma_{22})^2 + 2L\sigma_{23}^2 + 2M\sigma_{31}^2 + 2N\sigma_{12}^2 \right] \right)^{\frac{1}{2}} \quad (10)$$

In the case of the upsetting test of collar workpiece, at the free surface one of the three components of the stress is equal to zero and the shear stresses are equal to zero, too.

$$\sigma_{12} = \sigma_{23} = \sigma_{31} = 0.$$

The above equation becomes:

$$F(\sigma_{22} - \sigma_{33})^2 + G(\sigma_{33} - \sigma_{11})^2 + H(\sigma_{11} - \sigma_{22})^2 = 1 \quad (11)$$

But in all directions there is only one of stress components then:

$$\sigma_{11} = \sigma_{22} = 0$$

and the equivalent stress becomes:

$$\bar{\sigma}_{eq} = \left( \frac{\sqrt{3}[\sigma_{33}^2(F+G)]}{2\sqrt{(FH+FG+GH)}} \right)^{\frac{1}{2}} \quad (12)$$

The equivalent strain can be expressed as :

$$\bar{\varepsilon} = \frac{\sqrt{6(F+G+H)} \times \sqrt{\frac{(G^2+HF+GH)^2}{F+G}} \times \ln \frac{h_0}{h}}{3(HF+FG+GH)} \quad (13)$$

The values of anisotropy parameters can be calculated by solving these equations:

$$(F+G)\sigma_y = m_1 \quad (14)$$

$$\frac{G-H}{G+H} = m_2 \quad (15)$$

$$\frac{H-F}{F+H} = m_3 \quad (16)$$

where  $\sigma_y$  is the yield stress and  $m_1$ ,  $m_2$  and  $m_3$  are the slope of the curve lines in the Fig. 2 where  $a$  and  $b$  are principal axes of the ellipse of deformed specimen (Fig. 3).

The three components of strain rate can be calculated from the flow rule equation as:

$$\dot{\varepsilon}_{ij} = \dot{\lambda} \frac{\partial f}{\partial \sigma_{ij}} \quad (17)$$

and

$$\varepsilon_{ii} = a_{ii} \left( \ln \frac{h}{h_0} \right)^{b_0} \quad (18)$$

$$\dot{\varepsilon}_{ii} = \frac{\partial \varepsilon_{ii}}{\partial h} \frac{\partial h}{\partial t} = \frac{\partial \varepsilon_{ii}}{\partial h} v \quad (19)$$

where  $v$  is the velocity of the punch,  $h_0$  is the initial height of the work piece,  $a$  and  $b$  are approximation parameters  $i = 2, 3 \dots$

And the equivalent strain rate  $\dot{\bar{\epsilon}}$  can be calculated as

$$\dot{\bar{\epsilon}} = \frac{\dot{\epsilon}_{22}\sigma_{22} + \dot{\epsilon}_{33}\sigma_{33}}{\bar{\sigma}} \tag{20}$$

and

$$\dot{\lambda} = \frac{\dot{\bar{\epsilon}}\bar{\sigma}}{4} \tag{21}$$

Repeating equations (17) and (19) we can calculate the real values of  $\sigma_{22}$  and  $\sigma_{33}$ .

Fig. 4 is illustrating the equivalent stress for one, four, and eight passes.

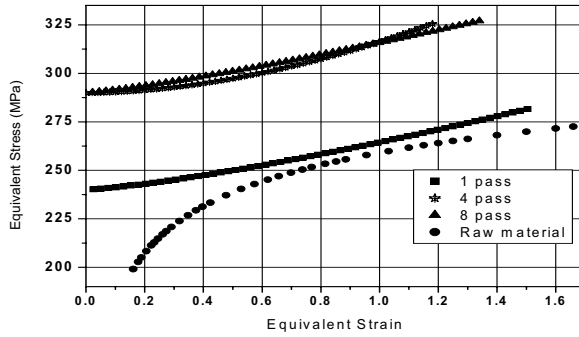

Fig. 4. Equivalent stress – Equivalent strain curves

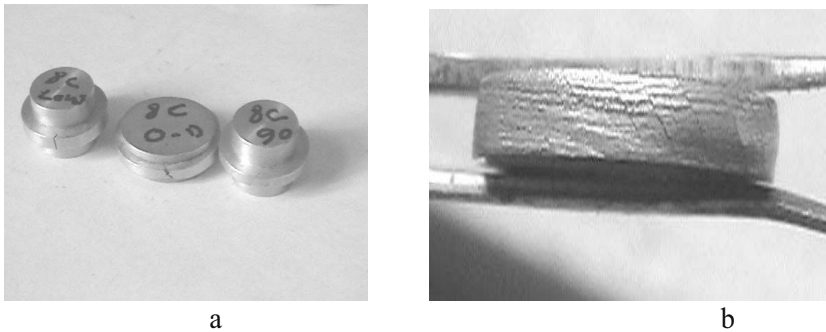

Fig. 5. Crack on the specimens. (a) Flanged specimen (b). Cylindrical specimen

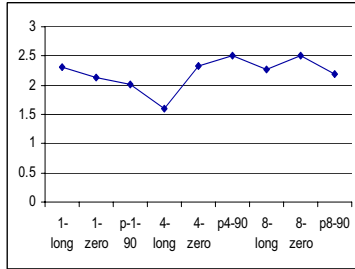

Fig.6-a. Constant value of Brozzo fracture criterion

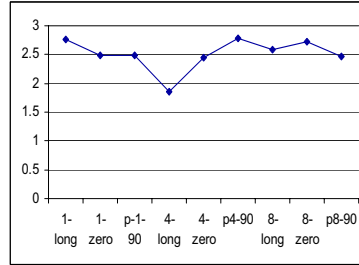

Fig.6-b. Constant value of Cockcroft and Latham fracture criterion

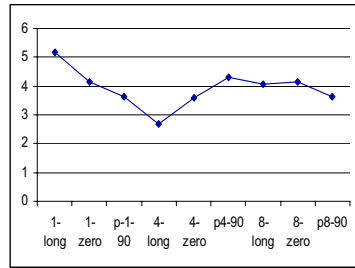

Fig.6-c. Constant value of Im & Argane fracture criterion

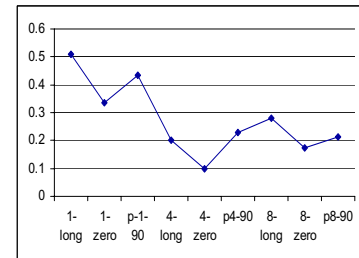

Fig.6-d. Constant value of Cockcroft and Latham fracture criterion

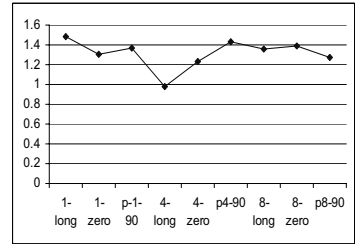

Fig.6-e. Constant value of Oyane et al. fracture criterion

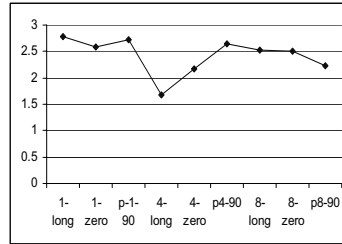

Fig.6-f. Constant value of Oh and Kobayashi criterion

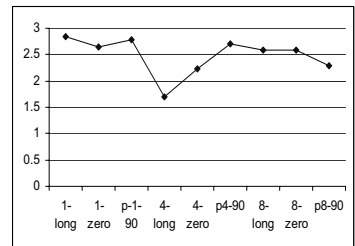

Fig.6-g. Constant value of Freudenthal fracture criterion

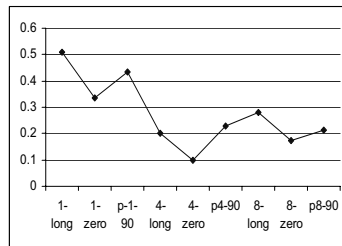

Fig.6-h. Constant value of Shabaic and Vujovic criterion



## 5. Results and Discussion

Cracks appeared on all types of the specimens after certain value of deformation (*Fig. 5*). Many criteria have been developed to predict ductile fracture. In this paper we apply the above eight types of fracture criteria. To apply these formulas we need a relation equation between criteria parameters and equivalent strain that can be created from the curves by using special computer program and take the integration. *Fig. 6* shows that the values of criteria constants are changing like a zigzag path.

From the results of experimental tests we concluded that the minimum value of ductile fracture criteria occurred at pass four in longitudinal direction of specimen's axes and the maximum value of ductile fracture outcome at pass one in longitudinal direction. The reasons for that are may be the fact that the value of effective strain at fracture in pass four is the lowest.

## 6. Summary and Conclusions

The properties of Al 6082 alloy changed when the material was subjected to ECAP process, they turned into anisotropic and the microstructure of materials transferred to nanostructured one as well as flow stresses became greater than those before ECAP method. After deformation the initial circular cross section of specimens changed to elliptical shape. It is reported that the minimum value of constant of fracture criteria occurred in pass four of ECAP in longitudinal direction.

## References

- [1] VENUGOPAL RAO, A. – RAMAKRISHNAN, N. – KRISHNA KUMAR, R., A Comparative Evaluation of The Theoretical Failure Criteria for Workability in Cold Forging: *Journal of Material Process Technology* **142** (2003) pp. 29–42.
- [2] FAHRETTIN OZTURK – DAERYONG LEE, Analysis of Forming Limits Using Ductile Fracture Criteria: *Journal of Material Process Technology* **147** (2004) pp. 397–404.
- [3] NARAYANA, S. V. S. – MURTY, B. – NAGESWARA RAO, – KASHYAP, B. P., Improved Ductile Fracture Criterion for Cold Forming of Spheroidised Steel, *Journal of Material Process Technology*, **142** (2004) pp. 94–101.
- [4] LANDRE, J. – PERTENCE, A. – CETLIN, P. R. – RODRIGUES, J. M. C. – MARTINS, P. A. F., On the Utilization of Ductile Fracture Criteria in Cold Forging, *Journal of Finite Element in Analysis and Design*, **39** (2003) pp. 175–186 .
- [5] WEILONG HU, An Orthotropic Yield Criterion in 3-D General Stress State: *International Journal Plasticity* **21** (2005) pp. 1771–1796.
- [6] KRÁLLICS, G. – FODOR, A. – AGENA, A., Anisotropic Mechanical Properties of Ultra-fine Grained Aluminum Alloy. Under publication paper
- [7] LIU, C. – HUNG, Y. – STOUT M. G., On The A Symmetric Yield Surface of Plastically Orthotropic Materials :A Phenomenological Study. *Acta Mater* **45** N0.6: P. 2397-2406 1997.
- [8] MONTMITONNET, P. – CHENOT, J. L., Introduction of Anisotropy in Viscoplastic 2D and 3D Finite-element Simulations of Hot Forging, *Journal of Materials Processing Thechnology* **53** (1995) pp. 662–683.