

Integration of Piezoelectric Wafer Sensors PWS Signal to Generate Ultrasonic Guided Waves in Planar and Cylindrical Waveguide

Ismaine Zitouni^{1*}, Hassan Rhimini¹, Abdelkerim Chouaf¹

¹ Laboratory of Mechanics, Engineering and Innovation, National High School of Electricity and Mechanics, Hassan II University, Route d'Eljadida Km 7, BP 8118 Oasis, Casablanca, Morocco

* Corresponding author, e-mail: ismaine.zitouni.doc20@ensem.ac.ma

Received: 19 December 2024, Accepted: 08 February 2025, Published online: 20 February 2025

Abstract

This paper explores the integration of piezoelectric wafers as both generators and receivers of ultrasonic-guided waves in planar and cylindrical waveguides. To this end, a ceramic Piezoelectric single crystal (PZT) generates mechanical waves in the structure. The experimental setup is thoroughly described, and the emitted signals are compared with those from two ultrasonic transducers to ensure signal integrity. A 1D Fast Fourier transform is utilized to monitor the resonant frequency of the generated waves. The study focuses on two types of waveguides: a multi-layer fiberglass composite plate [0° – 90°]₆ and a single-layer stainless steel pipeline. For each structure, a specific layout of PZT wafers is established to analyze the propagation of guided ultrasonic waves. The results show that PZT wafers effectively generated guided wave modes, allowing for the inspection of structural integrity in both the composite plate and pipeline. Notably, the signals were captured without any loss of information, highlighting the advantages of PZT wafers, including their consistent vibration frequency, simple use, and excellent contact with both flat and curved surfaces. This demonstrates the potential of PWS technology for reliable non-destructive testing in complex structures.

Keywords

ultrasonic, guided waves, PZT wafer, Fast Fourier transform, composite, pipeline

1 Introduction

Defects and imperfections in industry, such as cracks, porosity, inclusions, weld defects or corrosion, can weaken materials and structures, leading to failures, accidents and reduced product performance. These failures increase maintenance costs and can have serious consequences for safety and for the environment. It is essential to monitor these defects to prevent deterioration of both the structures and the products they carry. Ultrasonic Non-Destructive Testing (NDT) appears to be an advantageous solution for examining these defects [1–3]. Ultrasonic-guided waves (UGW) [4–6] offer great potential for non-destructive testing of structures. They are capable of propagating over long distances without significant attenuation, and monitoring the integrity of the structure. In practice, to conduct NDT correctly using UGW, it is imperative to know the dispersion patterns of these waves. In a guided structure, ultrasonic waves do not propagate freely but are confined by the material's physical boundaries, generating specific propagation modes (symmetric and antisymmetric)

influenced by thickness, geometry, mechanical properties, and ultrasonic frequency. These waves are classified into several types: Lamb waves (found in plates [7, 8]), Rayleigh waves (surface waves [9]), flexural waves (in tubes and bars [10, 11]), and guided shear waves [7]. Their propagation is described by dispersion curves, which illustrate the variation of wave velocity (phase and group) as a function of frequency, allowing for the identification of usable modes, the selection of an optimal frequency, and a better understanding of signal attenuation and dispersion. Dispersion curves are used to select the right mode for testing, depending on the frequency of the signal to be excited by the piezoelectric transducers. An electrical signal is then sent by the frequency generator, which is transformed into mechanical waves using the piezoelectric effect. The wave propagates through the inspected structure, undergoing reflections as it encounters imperfections. The signals are picked up by transducers positioned on the surface of the part. They are processed to

define existing defects. To optimize these steps, researchers have proposed the use of PZT wafers as wave generators and sensors, due to their diversity of sizes and shapes, making them suitable for compact devices or specific configurations depending on application requirements. Yang et al. [12] have analyzed the characteristics of Lamb waves generated by PZT wafers located in the middle of the thickness of a thin-walled plate. Subsequently, they integrated arrays of PZT wafers in epoxy-reinforced Woven Glass Fiber (WGF/epoxy) laminates with a stacking sequence of $[90/0]_4$. This strategy improved defect localization compared with surface-bonded PZTs. Lin and Giurgiutiu [13] explored the use of flexible piezoelectric sensors, such as piezoelectric polymer (PVDF), to transmit and receive Lamb waves on curved surfaces, in contrast to the fragile PZT sensors used on flat surfaces. Zhou et al. [14] have investigated the use of piezoelectric shear wafers (d36 type) for guided wave generation and damage detection in metal plates. Unlike traditional d31 sensors, d36 wafers induce shear deformation, generating shear horizontal (SH) waves that are larger than Lamb waves. The results show that these d36 wafers can simplify the quantitative estimation of the damage during structural monitoring. Giurgiutiu et al. [15] have explored the use of Piezoelectric Wafers Active Sensors (PWAS) to embed ultrasound in thin structures such as beams and plates, enabling in situ structural integrity monitoring. The study demonstrated the effectiveness of PWAS in detecting damage using the ultrasonic pulse-echo technique, and underlined the importance of high-frequency waves in optimizing sensor-structure interaction. Duan et al. [16] have introduced a graphene-based nanocomposite, which uses the tunnel effect to detect ultrasonic waves with high sensitivity and rapid response. Unlike traditional transducers such as PZT, this nanocomposite offered greater flexibility, surface compatibility and simpler fabrication. It was able to capture ultrasonic waves in a wide frequency range up to 1 MHz. Feng and Aliabadi [17] have examined the influence of composite thickness (2 mm, 4 mm, 9 mm) on integrated ultrasonic-guided waves at different temperatures, and assess the effectiveness of integrated transducers in detecting damage. Using an innovative method with phased-array PZT transducers created by inkjet printing, the study reveals that integrated PZT transducers are more sensitive than surface-mounted transducers for locating damage in thick composites. Wen et al. [18] have proposed a method for in situ inspection of thin-walled metal structures produced by Directed Energy Deposition (DED)

using ultrasonic-guided waves. Lamb waves are generated by a piezoelectric PZT transducer attached to the DED substrate, and measured with a non-contact laser vibrometer. The method has been tested on stainless steel (316L) structures, and have proven effective in detecting and locating defects, offering significant potential for real-time monitoring of the DED process. Roloff et al. [19] used commercial photopolymer resins combined with PZT piezoelectric particles to create 3D-printable piezoelectric composite sensors suitable for guided ultrasonic wave detection. In this study, these thin sensors successfully detect UGW, with performance comparable to commercial piezoelectric discs. Lee et al. [20] presents a diagnostic method based on guided ultrasonic waves PZT patch generation to detect sealant delamination in integrated circuit packages. The technique, validated against traditional tests, demonstrates high accuracy and potential for industrial quality assurance in integrated circuits.

This paper presents the integration of PZT wafers as generators and receivers of guided ultrasonic waves in a fiber-glass composite plate and a steel pipeline. A ceramic piezoelectric single crystal (PZT) is used to generate a mechanical wave in the waveguide. The experimental set-up employed is detailed, and the emitted signal is compared with that of two ultrasonic transducers to check its shape. A 1D Fast Fourier transform is applied to monitor the resonant frequency of the generated wave. Two waveguides are studied: a multi-layer glass-fiber composite plate $[0^\circ 90^\circ]_6$ and a single-layer stainless steel pipeline. In each case, a PZT layout is set up to analyze the propagation of guided ultrasonic waves in these complex structures. The PZT wafers were used to generate guided wave modes and inspect the structural integrity of the composite plate and pipeline. Signals were captured without loss of information, demonstrating the effectiveness of PZTs with their uniform vibration frequency, ease of use and good contact on both flat and curved surfaces. The main aim of this study is to propose PZT wafers as a source for generating ultrasonic-guided waves, replacing conventional ultrasonic sensors. PZTs offer simplicity of use, low cost and ease of operation. These advantages would considerably facilitate the work of non-destructive testers when inspecting complex multilayer and cylindrical composite parts, enabling them to detect defects that could compromise part function.

2 Experimental set-up

Non-destructive testing using guided ultrasonic waves is an inspection method designed to assess the quality and integrity of structures without altering the material.

The experimental generation of ultrasonic-guided waves relies on the use of transducers and wave propagation in specific structures, such as plates or pipes. It all starts with the choice of a suitable structure, which influences the wave modes generated. Piezoelectric [21, 22] or EMAT [23, 24] transducers are then used to convert an electrical signal into an ultrasonic wave. A signal generator sends an electrical pulse to the transducer, which produces the wave at the desired frequency. This frequency is crucial, as each wave mode is associated with a specific frequency range, requiring precise adjustment of the pulse parameters. The waves thus generated propagate through the structure and are picked up by a second transducer placed at a certain distance. The signals detected are then recorded using an oscilloscope or data acquisition system. Signal analysis enables us to study wave propagation, identifying wave modes, propagation speeds and dispersion phenomena.

These experiments are often used to characterize materials or detect defects in structures. In the following, a frequency generator dedicated to the production of ultrasonic frequencies is considered. At the same time, transducers are used to convert the electrical signal into ultrasonic waves. These transducers can be used either for transmission only, or for simultaneous transmission and reception. A digital oscilloscope is taken to process and display the captured signals. The configuration of this procedure is illustrated in Fig. 1.

The PZT (lead zirconate titanate piezoelectric) wafer is a type of piezoelectric ceramic wafers that exhibit the piezoelectric effect (Fig. 2), meaning that it can generate an electrical charge in response to mechanical stress and vice versa, while possessing high permittivity and dielectric dissipation values. These properties make PZT wafers useful in a variety of applications, including sensors, actuators and transducers, where the conversion of mechanical to electrical energy is important [25]. A common approach is to use PZT wafers created by sintering lead oxides. These wafers are

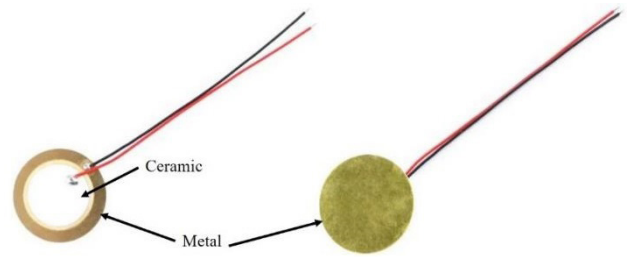

Fig. 2 Monocrystal PZT (12 mm × 200 kHz)

highly reactive to frequency signals of 200 kHz, so the resonant frequency of the buzzer is usually designed around 200 kHz during production. To improve low-frequency response, a double-diaphragm structure is commonly used.

Fig. 3 shows experimental signals generated by ultrasonic transducers with resonance frequencies of 2.25 MHz and 5 MHz. The signals generated by the transducers are in the form of a Hanning window-weighted signal. The Fast Fourier transform of the signals makes it possible to analyze with certainty the frequency generated by the transducer mentioned in the product reference. Fig. 4 shows the PZT excitation signal and its Fourier transform. It can be observed that the excitation frequency found is $f = 230$ kHz, which corresponds to the resonance frequency specified in the product reference documentation. Additionally, the signal emitted by the PZT wafers resembles those emitted by the transducers in Fig. 3 (a sinusoidal signal with a

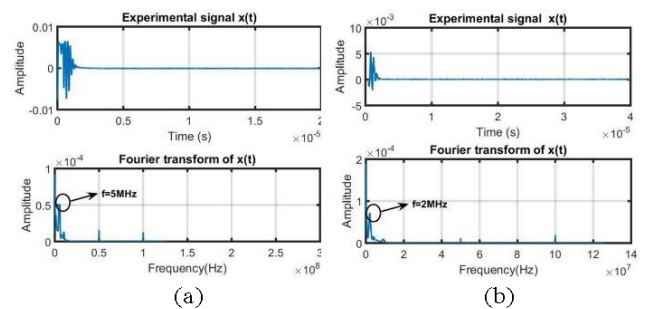

Fig. 3 Experimental signal and 1D Fast Fourier transform of the ultrasonic transducer (a) 1 and (b) 2

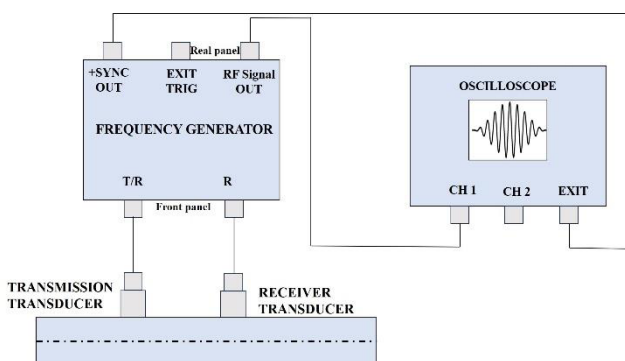

Fig. 1 Description of the experimental set-up

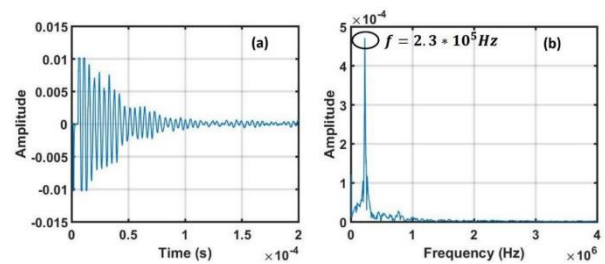

Fig. 4 (a) Experimental PZT signal and (b) 1D Fast Fourier transform of the PZT signal

Hanning window). The advantage of using PZTs instead of ultrasonic transducers lies in their light weight and low impact. In addition, when it comes to cylindrical geometries such as pipelines, transducers can be difficult to position due to their curvature and large dimensions, unlike PZTs which are more compact and easier to attach.

The expression of the Fast Fourier Transform is:

$$X(f) = \sum_{t=1}^N x(t) \omega_N^{(t-1)(f-1)}, \quad (1)$$

where $\omega_N = e^{2\pi i/N}$, f represent the frequency, t = represent the time, i is the imaginary entity, N is the total number of samples and $x(t)$ is the input signal.

3 Experimental results

3.1 Glass-fiber composite plate

Composites offer many advantages, such as light weight, increased strength and rigidity, excellent vibration damping capabilities, design flexibility and high resistance to corrosion and wear. These distinctive properties have led to their adoption in complex sectors such as the biomedical, sports, marine and construction industries. Glass fiber reinforced polymers (GFRP) are commonly used in modern vehicles to absorb energy, thanks to their moderate density and better specific mechanical properties than traditional metals [26]. In order to prevent potential malfunctions, ultrasonic-guided waves have been used to monitor the integrity of structures made of glass fiber composites [27, 28].

A square glass-fiber composite plate of side $a = 150$ mm, thickness $e = 4$ mm, Young's modulus of the fiber $E = 74$ GPa and Poisson's ratio $\nu = 0.23$ is considered. The plate contains 12 layers with orientation $[0^\circ 90^\circ]_6$. PZT transducers are positioned to capture the ultrasonic wave at positions $0^\circ, 45^\circ, 90^\circ, 135^\circ, 180^\circ, 225^\circ, 270^\circ$ and 315° relative to the excitation position. The excitation position is 20 mm from the edge. The choice of PZT positions in the plate is very important. Indeed, if the PZTs are very close to the edge, we'll get disturbing signals that describe the phenomena of edge reflections, and hence the appearance of evanescent modes [29, 30]. Another study should be carried out to separate these disturbances from the basic signal. The particularity of these modes is that they attenuate in the zone close to the edges. PZTs must be outside this zone to avoid disturbance. The choice of layer orientation $[0^\circ 90^\circ]_6$ results in wave modes propagating through the thickness of the laminate, producing a global vibration of the waveguide. Layer orientation plays a crucial role in wave propagation [3]. We opted for an

asymmetrical configuration of the layers in relation to the central layer. In addition, the selected fiber has a relatively low Young's modulus, which enables us to obtain wave modes with very low propagation velocities in the dispersion curves. This advantage facilitates the detection of relatively small defects. Fig. 5 shows the arrangement of the PZTs on the composite plate. Fig. 6 shows the signals captured by the PZTs at angles $0^\circ, 45^\circ, 90^\circ, 135^\circ, 180^\circ, 225^\circ, 270^\circ$ and 315° . These signals represent a circular scan of diameter $D_T = 80$ mm. It can be seen that the wave propagates uniformly in all directions, with a clear symmetry between the signals collected, particularly for the $45^\circ/315^\circ, 90^\circ/270^\circ$ and $135^\circ/225^\circ$ angle pairs. In addition, the shape of the signals remains unchanged with no sign of significant attenuation, indicating that the inspection zone is free of defects. PZT wafers have demonstrated their ability to

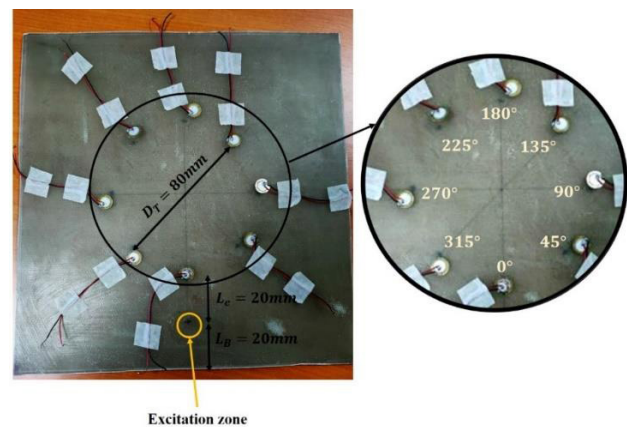

Fig. 5 Transducer positioning in the composite plate

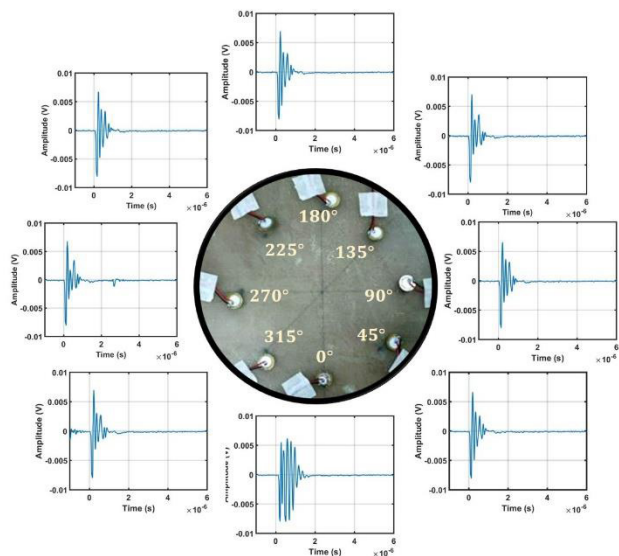

Fig. 6 Signals picked up by PZT transducers for angles $0^\circ, 45^\circ, 90^\circ, 135^\circ, 180^\circ, 225^\circ, 270^\circ$ and 315°

generate and capture ultrasonic-guided waves with ease of use in inspection operations. In addition, PZT wafers have the advantage of being relatively inexpensive, while ensuring effective contact with the waveguide, thus minimizing energy losses during wave transmission.

3.2 Steel pipeline

Cylindrical structures, such as pipelines, are vulnerable to a variety of defects, including corrosion, cracks, erosion and weld defects, which compromise their integrity and increase the risk of leaks or ruptures. Ultrasonic-guided wave offers an alternative to control these structures [31, 32]. In this section, the aim is to generate ultrasonic-guided waves by PWS in a steel pipeline. A steel pipeline is considered of length $L = 100$ cm, thickness $e = 3$ cm, Young's modulus $E = 200$ GPa and Poisson's coefficient $\nu = 0.3$. The PZT is positioned at a distance of 10 cm from the edges to avoid edge reflections and near-field phenomena [29, 30, 33]. Other PZTs positions are considered to act as signal receivers. Signals are planned to be measured every 10 cm from the emission source, at angles of 0° , 45° , 90° , 135° , 180° , 225° , 270° and 315° , to obtain a complete mapping of the wave (see Fig. 7).

Fig. 8 shows signals picked up by PZTs at positions 100 mm, 200 mm, 300 mm, 400 mm and 500 mm oriented in the same direction as the incidence position. Fig. 9 shows a polar representation of the frequency captured by the transducers for the directions 0° , 45° , 90° , 135° , 180° , 225° , 270° and 315° at the same positions mentioned above. It is noted that the ultrasonic wave propagates along the pipeline

and also across its circumference, resulting in both longitudinal and torsional modes [34]. Furthermore, when examining the signal picked up by the transducer at 0° in all positions, it becomes evident that the farther the distance from the emission source, the more the amplitude of the wave packet decreases. This decrease can be attributed to the inherent attenuation of the material and the presence of microscopic defects that cause partial reflection of the wave packet. Moreover, during the preparation of our pipeline, we carried out brushing and sanding of the external surface to remove impurities. However, no surface treatment was performed inside the pipeline due to the difficulty of access to this area. Consequently, the internal surface may have defects that could interact with the propagating wave, leading to increased reflection and, therefore, wave attenuation.

In addition, we observe that the longitudinal modes are more energetic than the modes captured along the circumference. This can be seen in Table 1, which reports

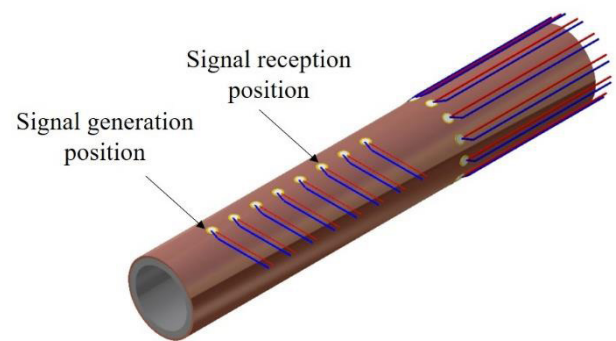

Fig. 7 Positioning the PZTs in the pipeline

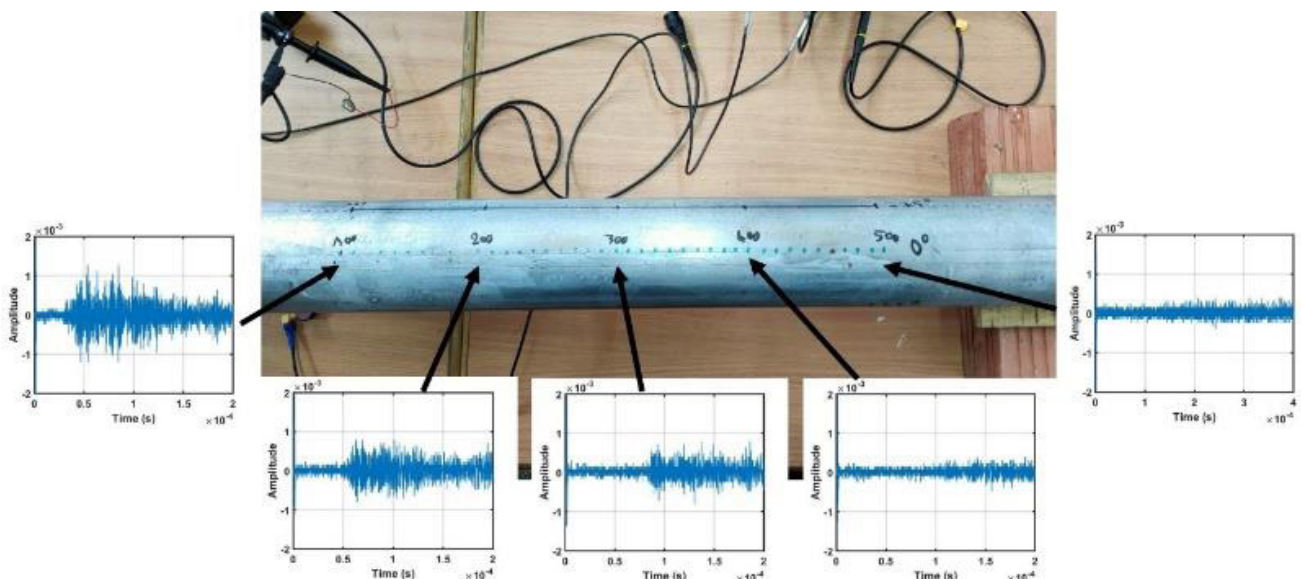

Fig. 8 Longitudinal UGW propagation in the steel pipe

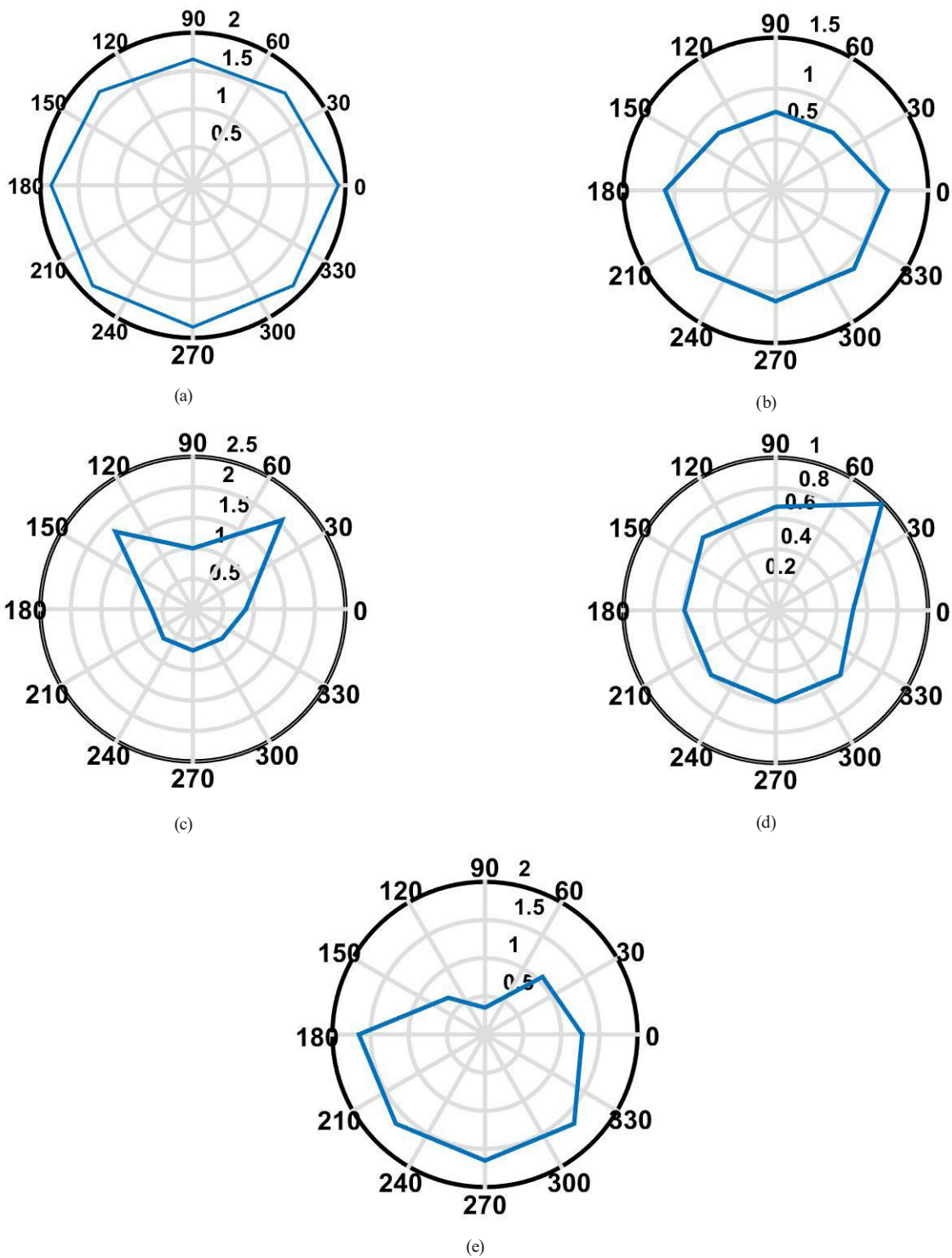

Fig. 9 Polar representation of frequencies as a function of sensors positions at a distance of (a) 100 mm, (b) 200 mm, (c) 300 mm, (d) 400 mm and (e) 500 mm from the emission source

the frequencies obtained by 1D Fast Fourier transform of the signals captured by the 0°, 90°, 180° and 270° transducers for positions 100 mm, 200 mm, 300 mm, 400 mm and 500 mm. This due to reflections caused by the curved shape of the pipeline. Finally, noise is present

in the signal (small vibrations), which may be due to several hardware-related factors, including inadequate contact between the transducers and the pipeline, noise from the frequency generator, and contact issues between the transducers and the oscilloscope.

Table 1 IFFDT of the captured signal of the transducer for angle 0°, 90°, 180° and 270°

Position of the transducer	Angle (°)	Frequency IFFDT (signal) (kHz)
100 mm	0	1.9070
	90	1.6520
	180	1.8590
	270	1.8590
200 mm	0	1.1020
	90	0.7709
	180	1.0900
	270	1.0900
300 mm	0	0.8679
	90	0.9973
	180	0.6799
	270	0.6799
400 mm	0	0.5072
	90	0.6781
	180	0.6000
	270	0.6000
500 mm	0	1.2750
	90	0.3510
	180	1.6530
	270	1.6530

4 Conclusion

This study highlights the integration of piezoelectric wafers as both generators and receivers of guided ultrasonic waves in planar and cylindrical waveguides. The use of a ceramic piezoelectric single crystal to generate mechanical waves has been thoroughly investigated, with a detailed description of the experimental setup. A thorough frequency analysis of

the excitation signal was carried to monitor the excitation signal of the PWS. The emitted signals were compared to those from traditional ultrasonic transducers, ensuring their integrity. Employing a 1D Fast Fourier transform allowed for the monitoring of resonant frequencies. The research focused on a multi-layer fiberglass composite plate and a single-layer stainless steel pipeline, demonstrating effective generation of guided wave modes by the PZT wafers. The results revealed that structural integrity could be reliably inspected without information loss, underscoring the benefits of PZT technology. Its consistent vibration frequency, ease of use, and excellent contact on various surfaces make it a promising tool for non-destructive testing in complex structures, paving the way for enhanced safety and maintenance in engineering applications. PZT wafers have several disadvantages: they are fragile and prone to breaking with repeated handling, their performance is sensitive to temperature variations which limits their use in unstable environments, their reduced durability requires frequent replacement, and their frequency limitations pose a significant drawback in non-destructive testing. PZTs have a specific resonant frequency, and their efficiency decreases when the frequency used deviates from this optimal value, restricting their application in inspections that require precise frequency ranges to detect specific types of defects, particularly small ones or those in complex composite materials.

Acknowledgements

On behalf of all the authors, the corresponding author declares that there is no conflict of interest in the research, authorship, and publication of this paper. The author(s) received no financial support for the research, authorship, and publication of this article.

References

- [1] Zang, X., Xu, Z. D., Lu, H., Zhu, C., Zhang, Z. "Ultrasonic guided wave techniques and applications in pipeline defect detection: A review", *International Journal of Pressure Vessels and Piping*, 206, 105033, 2023.
<https://doi.org/10.1016/j.ijpvp.2023.105033>
- [2] Zhang, M., Guo, Y. B., Zhang, Z., He, R. B., Wang, D. G., Chen, J. Z., Yin, T. "Extraction of pipeline defect feature based on variational mode and optimal singular value decomposition", *Petroleum Science*, 20, pp. 1200–1216, 2023.
<https://doi.org/10.1016/j.petsci.2022.11.007>
- [3] Zitouni, I., Rhimini, H., Chouaf, A. "A combined Newton–bisection approach for calculating the dispersion curves in anisotropic multilayered waveguides", *Journal of Vibration Engineering & Technologies*, 12(3), pp. 5189–5201, 2024.
<https://doi.org/10.1007/s42417-023-01191-1>
- [4] Zupančič, B., Prokop, Y., Nikonov, A. "FEM analysis of dispersive elastic waves in three-layered composite plates with high contrast properties", *Finite Elements in Analysis and Design*, 193, 103553, 2021.
<https://doi.org/10.1016/j.finel.2021.103553>
- [5] Zitouni, I., Rhimini, H., Chouaf, A. "Modeling the propagation of ultrasonic guided waves in a composite plate by a spectral approximation method", *Engineering Transactions*, 71(2), pp. 213–227, 2023.
<https://doi.org/10.24423/EngTrans.3073.20230510>
- [6] Zitouni, I., Rhimini, H., Chouaf, A. "Comparative study of the spectral method, DISPERSE and other classical methods for plotting the dispersion curves in anisotropic plates", *Journal of Applied and Computational Mechanics*, 9(4), pp. 955–973, 2023.
<https://doi.org/10.22055/jacm.2023.42530.3941>

- [7] Nayfeh, A. H., Chimenti, D. E. "Free wave propagation in plates of general anisotropic media", *Journal of Applied Mechanics*, 56(4), pp. 881–886, 1989.
<https://doi.org/10.1115/1.3176186>
- [8] Zhang, X., Chen, L., Du, W., Liu, G., Zhang, Z. "Thermo-acoustoelastic modeling of guided wave propagation in plate/shell structures under temperature-stress coupling", *Mechanical Systems and Signal Processing*, 220, 111693, 2024.
<https://doi.org/10.1016/j.ymssp.2024.111693>
- [9] Zerwer, A., Polak, M. A., Santamarina, J. C. "Wave propagation in thin Plexiglas plates: implications for Rayleigh waves", *NDT & E International*, 33(1), pp. 33–41, 2000.
[https://doi.org/10.1016/S0963-8695\(99\)00010-9](https://doi.org/10.1016/S0963-8695(99)00010-9)
- [10] Cong, M., Wu, X., Liu, R. "Dispersion analysis of guided waves in the finned tube using the semi-analytical finite element method", *Journal of Sound and Vibration*, 401, pp. 114–126, 2017.
<https://doi.org/10.1016/j.jsv.2017.04.037>
- [11] Li, F., Liu, Z., Sun, X., Li, H., Meng, G. "Propagation of guided waves in pressure vessel", *Wave Motion*, 52, pp. 216–228, 2015.
<https://doi.org/10.1016/j.wavemoti.2014.10.005>
- [12] Yang, B., Xuan, F.-Z., Jin, P., Hu, C., Biao, X., Dan, L., Yanxun, X., Hongshuai, L. "Damage Localization in Composite Laminates by Building in PZT Wafer Transducers: A Comparative Study with Surface-Bonded PZT Strategy", *Advanced Engineering Materials*, 21(3), 1801040, 2019.
<https://doi.org/10.1002/adem.201801040>
- [13] Lin, B., Giurgiutiu, V. "Modeling and testing of PZT and PVDF piezoelectric wafer active sensors", *Smart Materials and Structures*, 15(4), 1085, 2006.
<https://doi.org/10.1088/0964-1726/15/4/022>
- [14] Zhou, W., Li, H., Yuan, F.-G. "Guided wave generation, sensing and damage detection using in-plane shear piezoelectric wafers", *Smart Materials and Structures*, 23(1), 015014, 2013.
<https://doi.org/10.1088/0964-1726/23/1/015014>
- [15] Giurgiutiu, V., Bao, J., Zhao, W. "Piezoelectric wafer active sensor embedded ultrasonics in beams and plates", *Experimental Mechanics*, 43(4), pp. 428–449, 2003.
<https://doi.org/10.1007/BF02411348>
- [16] Duan, F., Liao, Y., Zeng, Z., Hao, J., Limin, Z., Zhong, Z. "Graphene-based nanocomposite strain sensor response to ultrasonic guided waves", *Composites Science and Technology*, 174, pp. 42–49, 2019.
<https://doi.org/10.1016/j.compscitech.2019.02.011>
- [17] Feng, T., Aliabadi, M. H. F. "Influence of Composite Thickness on Ultrasonic Guided Wave Propagation for Damage Detection Using Embedded PZT Transducers", *Applied Sciences*, 13(18), 10474, 2023.
<https://doi.org/10.3390/app131810474>
- [18] Wen, F., Gao, S., Song, X., Shi, F. "Piezoelectric-laser ultrasonic inspection and monitoring of thin-walled structure fabricated by directed energy deposition process based on guided waves", *Ultrasonics*, 138, 107255, 2024.
<https://doi.org/10.1016/j.ultras.2024.107255>
- [19] Roloff, T., Mitkus, R., Lion, J. N., Sinapius, M. "3D-printable piezoelectric composite sensors for acoustically adapted guided ultrasonic wave detection", *Sensors*, 22(18), 6964, 2022.
<https://doi.org/10.3390/s22186964>
- [20] Lee, H., Koo, B., Chattopadhyay, A., Neerukatti, R. K., Liu, K. C. "Damage detection technique using ultrasonic guided waves and outlier detection: Application to interface delamination diagnosis of integrated circuit package", *Mechanical Systems and Signal Processing*, 160, 107884, 2021.
<https://doi.org/10.1016/j.ymssp.2021.107884>
- [21] Zhu, C., Xu, Z.-D., Zang, X., Dong, Y. R., Li, Q.-Q., Lu, Y. "Generation of bidirectional shear horizontal guided waves by size optimization of face-shear piezoelectric transducers", *Applied Acoustics*, 222, 110055, 2024.
<https://doi.org/10.1016/j.apacoust.2024.110055>
- [22] Zhou, S., Shen, Y. "Self-Sensing Piezoelectric Composite Structures via Generation and Reception of Ultrasonic Guided Waves", In: *ASME International Mechanical Engineering Congress and Exposition*, New Orleans, LA, USA, 2023, V001T01A022. ISBN: 978-0-7918-8758-5
<https://doi.org/10.1115/IMECE2023-112726>
- [23] Zhang, X., Li, B., Zhang, X., Song, X., Tu, J., Cai, C., Yuan, J., Wu, Q. "Internal and external pipe defect characterization via high-frequency Lamb waves generated by unidirectional EMAT", *Sensors*, 23(21), 8843, 2023.
<https://doi.org/10.3390/s23218843>
- [24] Zhang, H., Yin, X., Ma, L., Ma, G., Shi, K., Zhang, Z., Yuan, X., Li, W. "Excitation characteristics of circumferential SH guided waves in steel pipes generated by EMATs with few-cycle PPM", *Ultrasonics*, 138, 107271, 2024.
<https://doi.org/10.1016/j.ultras.2024.107271>
- [25] Meshkinzar, A. M., Al-Jumaily, A. "Cylindrical piezoelectric PZT transducers for sensing and actuation", *Sensors*, 23(6), 3042, 2023.
<https://doi.org/10.3390/s23063042>
- [26] Rajak, D. K., Wagh, P. H., Linul, E. "Manufacturing technologies of carbon/glass fiber-reinforced polymer composites and their properties: A review", *Polymers*, 13(21), 3721, 2021.
<https://doi.org/10.3390/polym13213721>
- [27] Ibrahim, M. E., Smith, R. A., Wang, C. H. "Ultrasonic detection and sizing of compressed cracks in glass-and carbon-fibre reinforced plastic composites", *NDT & E International*, 92, pp. 111–121, 2017.
<https://doi.org/10.1016/j.ndteint.2017.08.004>
- [28] Schadow, F., Brackrock, D., Gaal, M., Heckel, T. "Ultrasonic inspection and data analysis of glass-and carbon-fibre-reinforced plastics", *Procedia Structural Integrity*, 7, pp. 299–306, 2017.
<https://doi.org/10.1016/j.prostr.2017.11.092>
- [29] Zitouni, I., Mekkaoui, M., Rhimini, H., Abdelkerim, C. "Innovative approach to modeling propagative, non-propagative and complex modes of ultrasonic guided waves", *Mechanics of Advanced Materials and Structures*, pp. 1–14, 2024.
<https://doi.org/10.1080/15376494.2024.2370032>
- [30] Ismaïne, Z., Hassan, R., Abdelkerim, C. "New spectral displacement post-processing approach for modeling ultrasonic guided waves", In: *3rd International Conference on Innovative Research in Applied Science, Engineering and Technology (IRASET)*, IEEE, Mohammedia, Morocco, 2023, pp. 1–8. ISBN: 979-8-3503-9837-3
<https://doi.org/10.1109/IRASET57153.2023.10152927>

- [31] Lyu, F., Zhou, X., Ding, Z., Qiao X., Song, D. "Application Research of Ultrasonic- Guided Wave Technology in Pipeline Corrosion Defect Detection: A Review", *Coatings*, 14(3), 358, 2024. <https://doi.org/10.3390/coatings14030358>
- [32] Ghavamian, A., Mustapha, F., Baharudin, B. T. H. T., Yidris, N. "Detection, Localisation and Assessment of Defects in Pipes Using Guided Wave Techniques: A Review", *Sensors*, 18(12), 4470, 2018. <https://doi.org/10.3390/s18124470>
- [33] Zitouni, I., Rhimini, H., Chouaf, A. "Control of a 3D Printed Carbon Fiber Reinforced Plate by Ultrasonic Guided Wave", In: Zarbane, K., Beidouri, Z. (eds.) *Proceedings of CASICAM 2022*, 2022, pp. 229–241. ISBN: 978-3-031-32927-2 https://doi.org/10.1007/978-3-031-32927-2_21
- [34] Zitouni, I., Rhimini, H., Chouaf, A. "Spectral method for modeling the Dispersion of complex guided wave modes in anisotropic pipeline", *Journal of Computational Applied Mechanics*, 55(3), pp. 473–484, 2024. <https://doi.org/10.22059/jcamech.2024.376537.1090>